

ROBOTICS

# Product manual

## IRB 910SC



Trace back information:  
Workspace 23D version a14  
Checked in 2023-12-12  
Skribenta version 5.5.019

**Product manual**  
**IRB 910SC-3/0.45**  
**IRB 910SC-3/0.55**  
**IRB 910SC-3/0.65**

IRC5

Document ID: 3HAC056430-001

Revision: N

The information in this manual is subject to change without notice and should not be construed as a commitment by ABB. ABB assumes no responsibility for any errors that may appear in this manual.

Except as may be expressly stated anywhere in this manual, nothing herein shall be construed as any kind of guarantee or warranty by ABB for losses, damage to persons or property, fitness for a specific purpose or the like.

In no event shall ABB be liable for incidental or consequential damages arising from use of this manual and products described herein.

This manual and parts thereof must not be reproduced or copied without ABB's written permission.

Keep for future reference.

Additional copies of this manual may be obtained from ABB.

Original instructions.

© Copyright 2016-2023 ABB. All rights reserved.  
Specifications subject to change without notice.



# Table of contents

Overview of this manual .....	9
Product documentation .....	14
How to read the product manual .....	16
<b>1 Safety</b> .....	<b>17</b>
1.1 Safety information .....	17
1.1.1 Limitation of liability .....	17
1.1.2 Requirements on personnel .....	18
1.2 Safety signals and symbols .....	19
1.2.1 Safety signals in the manual .....	19
1.2.2 Safety symbols on manipulator labels .....	21
1.3 Robot stopping functions .....	27
1.4 Safety during installation and commissioning .....	28
1.5 Safety during operation .....	31
1.6 Safety during maintenance and repair .....	32
1.6.1 Safety during maintenance and repair .....	32
1.6.2 Emergency release of the robot axes .....	35
1.6.3 Brake testing .....	36
1.7 Safety during troubleshooting .....	37
1.8 Safety during decommissioning .....	38
<b>2 Installation and commissioning</b> .....	<b>39</b>
2.1 Introduction to installation and commissioning .....	39
2.2 Unpacking .....	40
2.2.1 Pre-installation procedure .....	40
2.2.2 Technical data .....	41
2.2.3 Dimensions .....	45
2.2.4 Working range .....	47
2.2.5 Risk of tipping/stability .....	51
2.2.6 The unit is sensitive to ESD .....	53
2.3 On-site installation .....	54
2.3.1 Lifting robot with lifting accessories .....	54
2.3.2 Manually releasing the brakes .....	62
2.3.3 Orienting and securing the robot .....	64
2.3.4 Loads fitted to the robot, stopping time and braking distances .....	66
2.3.5 Fitting equipment on the robot .....	67
2.4 Restricting the working range .....	69
2.4.1 Axes with restricted working range .....	69
2.4.2 Mechanically restricting the working range .....	70
2.5 Electrical connections .....	72
2.5.1 Robot cabling and connection points .....	72
2.5.2 Customer connections .....	74
2.6 Start of robot in cold environments .....	76
2.7 Test run after installation, maintenance, or repair .....	77
<b>3 Maintenance</b> .....	<b>79</b>
3.1 Introduction .....	79
3.2 Service Information System (SIS) .....	80
3.3 Maintenance schedule .....	81
3.3.1 Specification of maintenance intervals .....	81
3.3.2 Maintenance schedule .....	82
3.4 Inspection activities .....	84
3.4.1 Inspecting the cabling .....	84
3.4.2 Inspecting the information labels .....	85
3.4.3 Inspecting the ball screw spline unit .....	88
3.4.4 Inspecting axis-1 and axis-2 mechanical stops .....	91

## Table of contents

---

3.4.5	Inspecting the timing belts .....	94
3.5	Replacement/changing activities .....	102
3.5.1	Replacing the battery pack .....	102
3.6	Lubrication activities .....	113
3.6.1	Lubricating the ball screw spline unit .....	113
3.7	Cleaning activities .....	116
3.7.1	Cleaning the IRB 910SC .....	116
<b>4</b>	<b>Repair</b> .....	<b>119</b>
4.1	Introduction .....	119
4.2	General procedures .....	120
4.2.1	Cut the paint or surface on the robot before replacing parts .....	120
4.2.2	Mounting instructions for sealings .....	121
4.3	Cable harness .....	125
4.3.1	Replacing the main cable package .....	125
4.3.2	Replacing the EIB unit .....	149
4.3.3	Replacing the PCB board .....	159
4.3.4	Replacing the EIB mounting plate .....	167
4.3.5	Replacing the floor cables .....	186
4.3.6	Replacing the brake release harness .....	194
4.4	Upper arm .....	199
4.4.1	Replacing the upper arm .....	199
4.4.2	Replacing the ball screw spline unit .....	232
4.4.3	Replacing the axis-3 timing belt .....	249
4.4.4	Replacing the axis-4 timing belts .....	259
4.4.5	Replacing the axis-2 mechanical stop .....	274
4.5	Lower arm and base .....	279
4.5.1	Replacing the lower arm .....	279
4.5.2	Replacing the base .....	288
4.5.3	Replacing the axis-1 mechanical stop .....	299
4.6	Drive units .....	302
4.6.1	Replacing the axis-1 drive unit .....	302
4.6.2	Replacing the axis-2 drive unit .....	311
4.6.3	Replacing the axis-3 drive unit .....	322
4.6.4	Replacing the axis-4 drive unit .....	336
<b>5</b>	<b>Calibration</b> .....	<b>349</b>
5.1	Introduction to calibration .....	349
5.1.1	Introduction and calibration terminology .....	349
5.1.2	Calibration methods .....	350
5.1.3	When to calibrate .....	352
5.2	Synchronization marks and axis movement directions .....	353
5.2.1	Synchronization marks and synchronization position for axes .....	353
5.2.2	Calibration movement directions for all axes .....	354
5.3	Updating revolution counters .....	355
5.3.1	Updating revolution counters on IRC5 robots .....	355
5.4	Calibrating the robot .....	359
5.4.1	Calibration position .....	359
5.4.2	Calibrating axis 1 .....	360
5.4.3	Calibrating axis 2 .....	365
5.4.4	Calibrating axis 3 and axis 4 .....	370
5.5	Verifying the calibration .....	376
5.6	Checking the synchronization position .....	377
<b>6</b>	<b>Decommissioning</b> .....	<b>379</b>
6.1	Introduction to decommissioning .....	379
6.2	Environmental information .....	380

<b>7</b>	<b>Reference information</b>	<b>383</b>
7.1	Introduction .....	383
7.2	Applicable standards .....	384
7.3	Unit conversion .....	386
7.4	Specification of screws .....	387
7.5	Screw joints .....	388
7.6	Weight specifications .....	391
7.7	Standard toolkit .....	392
7.8	Special tools .....	393
7.9	Lifting accessories and lifting instructions .....	395
<b>8</b>	<b>Spare parts</b>	<b>397</b>
8.1	Spare part lists and illustrations .....	397
<b>9</b>	<b>Circuit diagrams</b>	<b>399</b>
9.1	Circuit diagrams .....	399
	<b>Index</b>	<b>401</b>

**This page is intentionally left blank**

# Overview of this manual

---

## About this manual

This manual contains instructions for:

- mechanical and electrical installation of the robot
- maintenance of the robot
- mechanical and electrical repair of the robot.

---

## Usage

This manual should be used during:

- installation, from lifting the robot to its work site and securing it to the foundation, to making it ready for operation
- maintenance work
- repair work and calibration.

---

## Who should read this manual?

This manual is intended for:

- installation personnel
- maintenance personnel
- repair personnel.

---

## Prerequisites

A maintenance/repair/installation craftsman working with an ABB Robot must:

- be trained by ABB and have the required knowledge of mechanical and electrical installation/repair/maintenance work.

---

## Product manual scope

The manual covers covers all variants and designs of the IRB 910SC. Some variants and designs may have been removed from the business offer and are no longer available for purchase.

---

## Organization of chapters

The manual is organized in the following chapters:

Chapter	Contents
Safety, service	Safety information that must be read through before performing any installation or service work on robot. Contains general safety aspects as well as more specific information on how to avoid personal injuries and damage to the product.
Installation and commissioning	Required information about lifting and installation of the robot.
Maintenance	Step-by-step procedures that describe how to perform maintenance of the robot. Based on a maintenance schedule that may be used to plan periodical maintenance.
Repair	Step-by-step procedures that describe how to perform repair activities of the robot. Based on available spare parts.

*Continues on next page*

## Overview of this manual

---

Continued

Chapter	Contents
Calibration information	Procedures that do not require specific calibration equipment. General information about calibration.
Decommissioning	Environmental information about the robot and its components.
Reference information	Useful information when performing installation, maintenance or repair work. Includes lists of necessary tools, additional documents, safety standards, etc.
Spare parts and exploded views	Reference to the spare part list for the robot.
Circuit diagram	Reference to the circuit diagram for the robot.

---

## References

Documentation referred to in the manual, is listed in the table below.

Document name	Document ID
<i>Product manual, spare parts - IRB 910SC</i>	<i>3HAC056433-001</i>
<i>Product specification - IRB 910SC</i>	<i>3HAC056431-001</i>
<i>Circuit diagram - IRB 910SC</i>	<i>3HAC056159-002</i>
<i>Product manual - IRC5 Compact</i>	<i>3HAC047138-001</i>
<i>Operating manual - IRC5 with FlexPendant</i>	<i>3HAC050941-001</i>
<i>Technical reference manual - Lubrication in gearboxes</i>	<i>3HAC042927-001</i>
<i>Technical reference manual - System parameters</i>	<i>3HAC050948-001</i>
<i>Operating manual - Emergency safety information</i>	<i>3HAC027098-001</i>
<i>Safety manual for robot - Manipulator and IRC5 or OmniCore controller<sup>i</sup></i>	<i>3HAC031045-001</i>

<sup>i</sup> This manual contains all safety instructions from the product manuals for the manipulators and the controllers.

---

## Revisions

Revision	Description
-	First edition.

Continues on next page

Revision	Description
A	<p>The following updates are done in this revision:</p> <ul style="list-style-type: none"> <li>• Working range of axis 4 has been updated. See <a href="#">Working range on page 49</a>.</li> <li>• The force and torque values under endurance load and maximum load have been updated. See <a href="#">Loads on foundation, robot on page 42</a>.</li> <li>• The interval of lubricating the ball screw spline unit is modified to every 100 km. See <a href="#">Activities and intervals, standard equipment on page 82</a>.</li> <li>• The grease for lubrication the ball screw spline unit is changed from AFB-LF to AFA. See "Required consumables" in <a href="#">Lubricating the ball screw spline unit on page 113</a> and <a href="#">Replacing the ball screw spline unit on page 232</a>.</li> <li>• The spare part numbers of base and lifting labels have been changed.</li> <li>• The instruction label of lifting the robot has been changed. See <a href="#">Location of labels on page 85</a>.</li> <li>• Washers and locking liquid Loctite 243 are used when refitting the base rear cover and floor cables, and at the same time, the tightening torque of related screws changes from 4.5 Nm to 2 Nm.</li> <li>• The tightening torque of the screws on base bottom cover is added, which is 2 Nm.</li> <li>• A caution reminding not to mix axis-1 and axis-2 drive units has been added in procedures of refitting the drive units.</li> <li>• Screws for fitting the calibration pins of axes 1 and 2 have been removed. See <a href="#">Calibrating axis 1 on page 361</a> and <a href="#">Calibrating axis 2 on page 366</a>.</li> </ul>
B	<ul style="list-style-type: none"> <li>• Information about customer connectors has been added. See <a href="#">Customer connections on page 74</a>.</li> <li>• Dimension drawing for fitting the end effector is updated. See <a href="#">Fitting of end effector to the ball screw spline shaft on page 67</a>.</li> <li>• Information about the grease used for lubricating the ball screw spline is updated.</li> <li>• Locking liquid Loctite 243 is not required when refitting the base rear cover and floor cables.</li> <li>• Calibration tools are not provided as a package so that the calibration toolkit is removed.</li> <li>• Fixing calibration block of axes 3 and 4 is fixed to the upper arm so that related repairing procedures are removed.</li> <li>• Minor corrections.</li> </ul>
C	<p>Published in release R17.1. The following updates are done in this revision:</p> <ul style="list-style-type: none"> <li>• The spare part number of the lower cover of the upper arm is changed from 3HAC055203-001 to 3HAC060106-001.</li> <li>• Upper and lower axis-3 and axis-4 stop blocks on the ball screw spline unit are added as spare parts.</li> <li>• Unnecessary screws on the lower cover of the upper arm are removed so that related figures are updated.</li> <li>• Every 100 miles column in Maintenance schedule is removed, the maintenance interval of inspecting the timing belt is updated</li> <li>• The Protection class is changed from IP30 to IP20.</li> </ul>

Continues on next page

Revision	Description
D	<p>Published in release R17.2. The following updates are made in this revision:</p> <ul style="list-style-type: none"> <li>Information about coupled axes in <a href="#">Updating revolution counters on IRC5 robots on page 355</a>.</li> <li>Caution about removing metal residues added in sections about SMB/EIB boards.</li> <li>Information about minimum resonance frequency added.</li> <li>Updated list of applicable standards.</li> <li>Added text regarding overhaul in section specification of maintenance intervals.</li> <li>Section <a href="#">Start of robot in cold environments on page 76</a> added.</li> </ul>
E	<p>Published in release R18.1. The following updates are made in this revision:</p> <ul style="list-style-type: none"> <li>Added sections in <a href="#">General procedures on page 120</a>.</li> <li>Safety restructured.</li> <li>Added information about SIS function for ball screw spline unit in <a href="#">Troubleshooting on page 80</a>.</li> <li>Information about myABB Business Portal added.</li> </ul>
F	<p>Published in release R18.2. The following updates are made in this revision:</p> <ul style="list-style-type: none"> <li>Added equipment fitting note and updated the end effector dimension figure.</li> <li>Moved the robot dimension information to section <a href="#">Unpacking on page 40</a>.</li> <li>Added customer connector information.</li> <li>Added replacement of brake release harness.</li> <li>Changed timing belt tension of axis 3 and axis 4.</li> </ul>
G	<p>Published in release R18.2. The following updates are made in this revision:</p> <ul style="list-style-type: none"> <li>Updated references.</li> </ul>
H	<p>Published in release 19B. The following updates are made in this revision:</p> <ul style="list-style-type: none"> <li>New touch up color Graphite White available. See <a href="#">Cut the paint or surface on the robot before replacing parts on page 120</a>.</li> <li>Corrected customer connector at the upper arm from R4.CP/CS to R3.CP/CS.</li> </ul>
J	<p>Published in release 20A. The following updates are made in this revision:</p> <ul style="list-style-type: none"> <li>Clarified and added information in mounting instructions for rotating sealings, see <a href="#">Mounting instructions for sealings on page 121</a>.</li> <li>Added AbsAcc label information. See <a href="#">Inspecting the information labels on page 85</a>.</li> </ul>
K	<p>Published in release 20D. The following updates are made in this revision:</p> <ul style="list-style-type: none"> <li>Option 610-1 Independent axis is removed so that description about maximum revolution of axis 4 is removed.</li> </ul>
L	<p>Published in release 21B. The following updates are done in this revision:</p> <ul style="list-style-type: none"> <li>Text regarding fastener quality is updated, see <a href="#">Fastener quality on page 68</a>.</li> <li>Text regarding diameter of air hoses is updated, see <a href="#">Customer connections on page 74</a>.</li> <li>Added grounding point information, see <a href="#">Robot cabling and connection points on page 72</a>.</li> </ul>
M	<p>Published in release 21C. The following updates are done in this revision:</p> <ul style="list-style-type: none"> <li>Updated the naming of timing belt tension adjustment tools, from acoustic tensiometer and tensiometer to sonic tension meter and dynamometer, respectively.</li> </ul>

Continues on next page



Revision	Description
N	<p>Published in release 23D. The following updates are done in this revision:</p> <ul style="list-style-type: none"><li data-bbox="687 338 1417 398">• Updated information about Gleitmo treated screws, see <a href="#">Screw joints on page 388</a>.</li><li data-bbox="687 400 1337 436">• Added axis positions for most stable transport position.</li></ul>

# Product documentation

---

### Categories for user documentation from ABB Robotics

The user documentation from ABB Robotics is divided into a number of categories. This listing is based on the type of information in the documents, regardless of whether the products are standard or optional.



#### Tip

All documents can be found via myABB Business Portal, [www.abb.com/myABB](http://www.abb.com/myABB).

---

### Product manuals

Manipulators, controllers, DressPack, and most other hardware is delivered with a **Product manual** that generally contains:

- Safety information.
- Installation and commissioning (descriptions of mechanical installation or electrical connections).
- Maintenance (descriptions of all required preventive maintenance procedures including intervals and expected life time of parts).
- Repair (descriptions of all recommended repair procedures including spare parts).
- Calibration.
- Troubleshooting.
- Decommissioning.
- Reference information (safety standards, unit conversions, screw joints, lists of tools).
- Spare parts list with corresponding figures (or references to separate spare parts lists).
- References to circuit diagrams.

---

### Technical reference manuals

The technical reference manuals describe reference information for robotics products, for example lubrication, the RAPID language, and system parameters.

---

### Application manuals

Specific applications (for example software or hardware options) are described in **Application manuals**. An application manual can describe one or several applications.

An application manual generally contains information about:

- The purpose of the application (what it does and when it is useful).
- What is included (for example cables, I/O boards, RAPID instructions, system parameters, software).
- How to install included or required hardware.
- How to use the application.

*Continues on next page*

- Examples of how to use the application.

---

**Operating manuals**

The operating manuals describe hands-on handling of the products. The manuals are aimed at those having first-hand operational contact with the product, that is production cell operators, programmers, and troubleshooters.

# How to read the product manual

---

### Reading the procedures

The procedures contain all information required for the installation or service activity and can be printed out separately when needed for a certain service procedure.

### Safety information

The manual includes a separate safety chapter that must be read through before proceeding with any service or installation procedures. All procedures also include specific safety information when dangerous steps are to be performed.

Read more in the chapter [Safety on page 17](#).

### Illustrations

The product is illustrated with general figures that does not take painting or protection type in consideration.

Likewise, certain work methods or general information that is valid for several product models, can be illustrated with illustrations that show a different product model than the one that is described in the current manual.

# 1 Safety

## 1.1 Safety information

### 1.1.1 Limitation of liability

---

**Limitation of liability**

Any information given in this manual regarding safety must not be construed as a warranty by ABB that the industrial robot will not cause injury or damage even if all safety instructions are complied with.

The information does not cover how to design, install and operate a robot system, nor does it cover all peripheral equipment that can influence the safety of the robot system.

In particular, liability cannot be accepted if injury or damage has been caused for any of the following reasons:

- Use of the robot in other ways than intended.
- Incorrect operation or maintenance.
- Operation of the robot when the safety devices are defective, not in their intended location or in any other way not working.
- When instructions for operation and maintenance are not followed as intended.
- Non-authorized design modifications of the robot.
- Repairs on the robot and its spare parts carried out by in-experienced or non-qualified personnel.
- Foreign objects.
- Force majeure.

---

**Spare parts and equipment**

ABB supplies original spare parts and equipment which have been tested and approved for their intended use. The installation and/or use of non-original spare parts and equipment can negatively affect the safety, function, performance, and structural properties of the robot. ABB is not liable for damages caused by the use of non-original spare parts and equipment.

# 1 Safety

---

## 1.1.2 Requirements on personnel

### 1.1.2 Requirements on personnel

---

#### General

Only personnel with appropriate training are allowed to install, maintain, service, repair, and use the robot. This includes electrical, mechanical, hydraulics, pneumatics, and other hazards identified in the risk assessment.

Persons who are under the influence of alcohol, drugs or any other intoxicating substances are not allowed to install, maintain, service, repair, or use the robot.

The plant liable must make sure that the personnel is trained on the robot, and on responding to emergency or abnormal situations.

---

#### Personal protective equipment

Use personal protective equipment, as stated in the instructions.

## 1.2 Safety signals and symbols

### 1.2.1 Safety signals in the manual







#### Introduction to safety signals

This section specifies all safety signals used in the user manuals. Each signal consists of:

- A caption specifying the hazard level (DANGER, WARNING, or CAUTION) and the type of hazard.
- Instruction about how to reduce the hazard to an acceptable level.
- A brief description of remaining hazards, if not adequately reduced.

#### Hazard levels

The table below defines the captions specifying the hazard levels used throughout this manual.

Symbol	Designation	Significance
	DANGER	Signal word used to indicate an imminently hazardous situation which, if not avoided, will result in serious injury.
	WARNING	Signal word used to indicate a potentially hazardous situation which, if not avoided, could result in serious injury.
	ELECTRICAL SHOCK	Signal word used to indicate a potentially hazardous situation related to electrical hazards which, if not avoided, could result in serious injury.
	CAUTION	Signal word used to indicate a potentially hazardous situation which, if not avoided, could result in slight injury.
	ELECTROSTATIC DISCHARGE (ESD)	Signal word used to indicate a potentially hazardous situation which, if not avoided, could result in severe damage to the product.
	NOTE	Signal word used to indicate important facts and conditions.

*Continues on next page*

# 1 Safety

---

## 1.2.1 Safety signals in the manual

*Continued*

Symbol	Designation	Significance
	TIP	Signal word used to indicate where to find additional information or how to do an operation in an easier way.



## 1.2.2 Safety symbols on manipulator labels

### Introduction to symbols

This section describes safety symbols used on labels (stickers) on the manipulator. Symbols are used in combinations on the labels, describing each specific warning. The descriptions in this section are generic, the labels can contain additional information such as values.



#### Note

The symbols on the labels on the product must be observed. Additional symbols added by the integrator must also be observed.



### Types of symbols

Both the manipulator and the controller are marked with symbols, containing important information about the product. This is important for all personnel handling the robot, for example during installation, service, or operation.

The safety labels are language independent, they only use graphics. See [Symbols on safety labels on page 21](#).

The information labels can contain information in text.

### Symbols on safety labels



Symbol	Description
 xx0900000812	<b>Warning!</b> Warns that an accident <i>may</i> occur if the instructions are not followed that can lead to serious injury, possibly fatal, and/or great damage to the product. It applies to warnings that apply to danger with, for example, contact with high voltage electrical units, explosion or fire risk, risk of poisonous gases, risk of crushing, impact, fall from height, etc.
 xx0900000811	<b>Caution!</b> Warns that an accident may occur if the instructions are not followed that can result in injury and/or damage to the product. It also applies to warnings of risks that include burns, eye injury, skin injury, hearing damage, crushing or slipping, tripping, impact, fall from height, etc. Furthermore, it applies to warnings that include function requirements when fitting and removing equipment where there is a risk of damaging the product or causing a breakdown.
 xx0900000839	<b>Prohibition</b> Used in combinations with other symbols.

*Continues on next page*



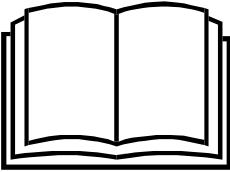
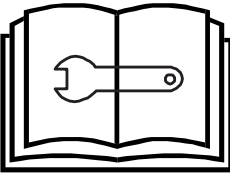
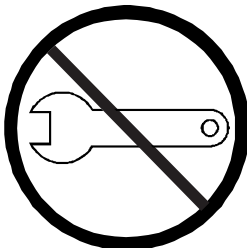
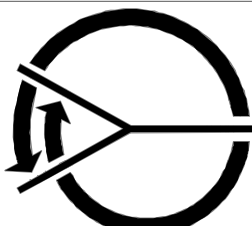

# 1 Safety

## 1.2.2 Safety symbols on manipulator labels

Continued

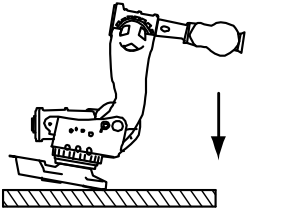
Symbol	Description
 xx0900000813	<b>See user documentation</b> Read user documentation for details. Which manual to read is defined by the symbol: <ul style="list-style-type: none"><li>• No text: <i>Product manual</i>.</li><li>• EPS: <i>Application manual - Electronic Position Switches</i>.</li></ul>
 xx0900000816	<b>Before disassembly, see product manual</b>
 xx0900000815	<b>Do not disassemble</b> Disassembling this part can cause injury.
 xx0900000814	<b>Extended rotation</b> This axis has extended rotation (working area) compared to standard.
 xx0900000808	<b>Brake release</b> Pressing this button will release the brakes. This means that the robot arm can fall down.

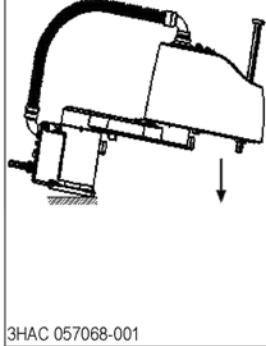

Continues on next page

Symbol	Description
 <p>xx0900000810</p>   <p>3HAC 057068-001</p> <p>xx1500002402</p>	<p><b>Tip risk when loosening bolts</b> The robot can tip over if the bolts are not securely fastened.</p>
 <p>xx0900000817</p>	<p><b>Crush</b> Risk of crush injuries.</p>





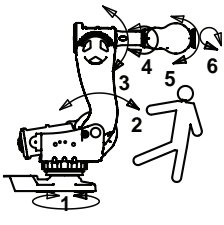
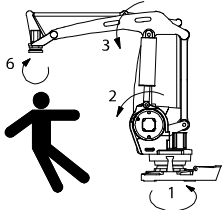
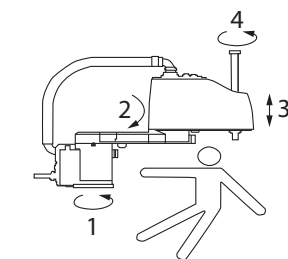

# 1 Safety

## 1.2.2 Safety symbols on manipulator labels

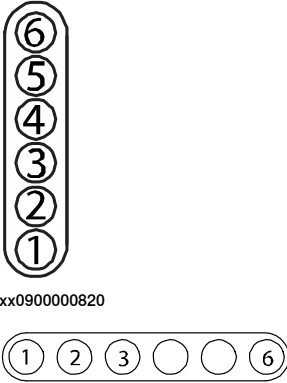
Continued

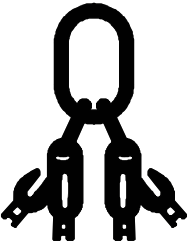
Symbol	Description
 xx0900000818  xx1300001087	<b>Heat</b> Risk of heat that can cause burns. (Both signs are used)
 xx0900000819  xx1000001141  xx1500002616	<b>Moving robot</b> The robot can move unexpectedly.

Continues on next page





Symbol	Description
 <p>xx0900000820</p> <p>xx1000001140</p>	<p><b>Brake release buttons</b></p>
 <p>xx0900000821</p>	<p><b>Lifting bolt</b></p>
 <p>xx1000001242</p>	<p><b>Adjustable chain sling with shortener</b></p>
 <p>xx0900000822</p>	<p><b>Lifting of robot</b></p>
 <p>xx0900000823</p>	<p><b>Oil</b> Can be used in combination with prohibition if oil is not allowed.</p>
 <p>xx0900000824</p>	<p><b>Mechanical stop</b></p>

Continues on next page

# 1 Safety

## 1.2.2 Safety symbols on manipulator labels

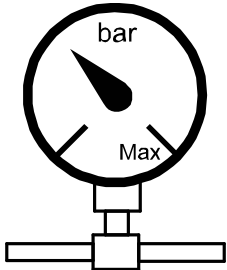
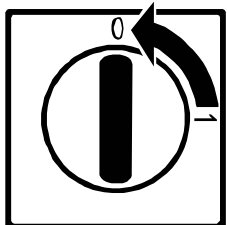
Continued

Symbol	Description
 xx1000001144	<b>No mechanical stop</b>
 xx0900000825	<b>Stored energy</b> Warns that this part contains stored energy. Used in combination with <i>Do not disassemble</i> symbol.
 xx0900000826	<b>Pressure</b> Warns that this part is pressurized. Usually contains additional text with the pressure level.
 xx0900000827	<b>Shut off with handle</b> Use the power switch on the controller.
 xx1400002648	<b>Do not step</b> Warns that stepping on these parts can cause damage to the parts.

### 1.3 Robot stopping functions

---

#### Protective stop and emergency stop

The protective stops and emergency stops are described in the product manual for the controller.

For more information see:

- *Product manual - IRC5 Compact*

# 1 Safety

---

## 1.4 Safety during installation and commissioning

### 1.4 Safety during installation and commissioning

---

#### National or regional regulations

The integrator of the robot system is responsible for the safety of the robot system.

The integrator is responsible that the robot system is designed and installed in accordance with the safety requirements set forth in the applicable national and regional standards and regulations.

The integrator of the robot system is required to perform a risk assessment.

---

#### Layout

The robot integrated to a robot system shall be designed to allow safe access to all spaces during installation, operation, maintenance, and repair.

If robot movement can be initiated from an external control panel then an emergency stop must also be available.

If the manipulator is delivered with mechanical stops, these can be used for reducing the working space.

A perimeter safeguarding, for example a fence, shall be dimensioned to withstand the following:

- The force of the manipulator.
- The force of the load handled by the robot if dropped or released at maximum speed.
- The maximum possible impact caused by a breaking or malfunctioning rotating tool or other device fitted to the robot.

The maximum TCP speed and the maximum velocity of the robot axes are detailed in the section *Robot motion* in the product specification for the respective manipulator.

Consider exposure to hazards, such as slipping, tripping, and falling.

Hazards due to the working position and posture for a person working with or near the robot shall be considered.

Hazards due to noise emission from the robot needs to be considered.

Consider hazards from other equipment in the robot system, for example, that guards remain active until identified hazards are reduced to an acceptable level.

---

#### Allergenic material

See [Environmental information on page 380](#) for specification of allergenic materials in the product, if any.

---

#### Securing the robot to the foundation

The robot must be properly fixed to its foundation/support, as described in the respective product manual.

When the robot is installed at a height, hanging, or other than mounted directly on the floor, there will be additional hazards.

---

*Continues on next page*



### Using lifting accessories and other external equipment

Ensure that all equipment used during installation, service and all handling of the robot are in correct condition for the intended use.

### Electrical safety

Incoming mains must be installed to fulfill national regulations.

The power supply wiring to the robot must be sufficiently fused and if necessary, it must be possible to disconnect it manually from the mains power.

The power to the robot must be turned off with the main switch and the mains power disconnected when performing work inside the controller cabinet. Lock and tag shall be considered.

Harnesses between controller and manipulator shall be fixed and protected to avoid tripping and wear.

Wherever possible, power on/off or rebooting the robot controller shall be performed with all persons outside the safeguarded space.



#### Note

Use a CARBON DIOXIDE (CO<sub>2</sub>) extinguisher in the event of a fire in the robot.

### Safety devices

The integrator is responsible for that the safety devices necessary to protect people working with the robot system are designed and installed correctly.

When integrating the robot with external devices to a robot system:

- The integrator of the robot system must ensure that emergency stop functions are interlocked in accordance with applicable standards.
- The integrator of the robot system must ensure that safety functions are interlocked in accordance with applicable standards.

### Other hazards

A robot may perform unexpected limited movement.



#### WARNING

Manipulator movements can cause serious injuries on users and may damage equipment.

The risk assessment should also consider other hazards arising from the application, such as, but not limited to:

- Water
- Compressed air
- Hydraulics

End-effector hazards require particular attention for applications which involve close human collaboration with the robot.

*Continues on next page*

# 1 Safety

---

## 1.4 Safety during installation and commissioning

*Continued*

---

### Pneumatic or hydraulic related hazards



#### Note

The pressure in the complete pneumatic or hydraulic systems must be released before service and maintenance.

All components in the robot system that remain pressurized after switching off the power to the robot must be marked with clearly visible drain facilities and a warning sign that indicates the hazard of stored energy.

Loss of pressure in the robot system may cause parts or objects to drop.

Dump valves should be used in case of emergency.

Shot bolts should be used to prevent tools, etc., from falling due to gravity.

All pipes, hoses, and connections have to be inspected regularly for leaks and damage. Damage must be repaired immediately.

---

### Verify the safety functions

Before the robot system is put into operation, verify that the safety functions are working as intended and that any remaining hazards identified in the risk assessment are mitigated to an acceptable level.

### 1.5 Safety during operation

#### Automatic operation

Verify the application in the operating mode manual reduced speed, before changing mode to automatic and initiating automatic operation.

#### Unexpected movement of robot arm



#### WARNING

Hazards due to the use of brake release devices and/or gravity beneath the manipulator shall be considered.

A robot may perform unexpected limited movement.



#### WARNING

Manipulator movements can cause serious injuries on users and may damage equipment.

# 1 Safety

## 1.6.1 Safety during maintenance and repair

## 1.6 Safety during maintenance and repair

### 1.6.1 Safety during maintenance and repair

#### General

Corrective maintenance must only be carried out by personnel trained on the robot. Maintenance or repair must be done with all electrical, pneumatic, and hydraulic power switched off, that is, no remaining hazards.

Hazards due to stored mechanical energy in the manipulator for the purpose of counterbalancing axes must be considered before maintenance or repair.

Never use the robot as a ladder, which means, do not climb on the controller, manipulator, including motors, or other parts. There are hazards of slipping and falling. The robot might be damaged.

Make sure that there are no tools, loose screws, turnings, or other unexpected parts remaining after maintenance or repair work.

When the work is completed, verify that the safety functions are working as intended.

#### Hot surfaces

Surfaces can be hot after running the robot, and touching these may result in burns. Allow the surfaces to cool down before maintenance or repair.

#### Allergic reaction

Warning	Description	Elimination/Action
 Allergic reaction	When working with lubricants there is a risk of an allergic reaction.	Make sure that protective gear like goggles and gloves are always worn.

#### Gearbox lubricants (oil or grease)

When handling oil, grease, or other chemical substances the safety information of the respective manufacturer must be observed.







#### Note

Take special care when handling hot lubricants.

Warning	Description	Elimination/Action
 Hot oil or grease	Changing and draining gearbox oil or grease may require handling hot lubricant heated up to 90 °C.	Make sure that protective gear like goggles and gloves are always worn during this activity.

*Continues on next page*

Warning	Description	Elimination/Action
 <b>Allergic reaction</b>	When working with lubricants there is a risk of an allergic reaction.	Make sure that protective gear like goggles and gloves are always worn.
 <b>Possible pressure build-up in gearbox</b>	When opening the oil or grease plug, there may be pressure present in the gearbox, causing lubricant to spray from the opening.	Open the plug carefully and keep away from the opening. Do not overfill the gearbox when filling.
 <b>Do not overfill</b>	Overfilling of gearbox lubricant can lead to internal over-pressure inside the gearbox which in turn may: <ul style="list-style-type: none"> <li>• damage seals and gaskets</li> <li>• completely press out seals and gaskets</li> <li>• prevent the robot from moving freely.</li> </ul>	Make sure not to overfill the gearbox when filling it with oil or grease. After filling, verify that the level is correct.
 <b>Specified amount depends on drained volume</b>	The specified amount of oil or grease is based on the total volume of the gearbox. When changing the lubricant, the amount refilled may differ from the specified amount, depending on how much has previously been drained from the gearbox.	After filling, verify that the level is correct.

### Hazards related to batteries

Under rated conditions, the electrode materials and liquid electrolyte in the batteries are sealed and not exposed to the outside.

There is a hazard in case of abuse (mechanical, thermal, electrical) which leads to the activation of safety valves and/or the rupture of the battery container. As a result under certain circumstances, electrolyte leakage, electrode materials reaction with moisture/water or battery vent/explosion/fire may follow.

Do not short circuit, recharge, puncture, incinerate, crush, immerse, force discharge or expose to temperatures above the declared operating temperature range of the product. Risk of fire or explosion.

Operating temperatures are listed in [Operating conditions, robot on page 43](#).

See safety instructions for the batteries in *Material/product safety data sheet - Battery pack (3HAC043118-001)*.

### Unexpected movement of robot arm



**WARNING**

Hazards due to the use of brake release devices and/or gravity beneath the manipulator shall be considered.

*Continues on next page*

# 1 Safety

---

## 1.6.1 Safety during maintenance and repair

*Continued*

A robot may perform unexpected limited movement.



### **WARNING**

Manipulator movements can cause serious injuries on users and may damage equipment.

---

### **Related information**

See also the safety information related to installation and operation.

### 1.6.2 Emergency release of the robot axes

#### Description

In an emergency situation, the brakes on a robot axis can be released manually by pushing a brake release button.

How to release the brakes is described in the section:

- [Manually releasing the brakes on page 62.](#)

The robot may be moved manually on smaller robot models, but larger models may require using an overhead crane or similar equipment.

#### Increased injury

Before releasing the brakes, make sure that the weight of the manipulator does not result in additional hazards, for example, even more severe injuries on a trapped person.



#### **DANGER**

When releasing the holding brakes, the robot axes may move very quickly and sometimes in unexpected ways.

Make sure no personnel is near or beneath the robot.

# 1 Safety

---

## 1.6.3 Brake testing

### 1.6.3 Brake testing

---

#### When to test

During operation, the holding brake of each axis normally wears down. A test can be performed to determine whether the brake can still perform its function.

---

#### How to test

The function of the holding brake of each axis motor may be verified as described below:

- 1 Run each axis to a position where the combined weight of the manipulator and any load is maximized (maximum static load).
- 2 Switch the motor to the MOTORS OFF.
- 3 Inspect and verify that the axis maintains its position.

If the manipulator does not change position as the motors are switched off, then the brake function is adequate.



#### Note

It is recommended to run the service routine *BrakeCheck* as part of the regular maintenance, see the operating manual for the robot controller.

For robots with the option SafeMove, the *Cyclic Brake Check* routine is recommended. See the manual for SafeMove in [References on page 10](#).



## 1.7 Safety during troubleshooting

### General

When troubleshooting requires work with power switched on, special considerations must be taken:

- Safety circuits might be muted or disconnected.
- Electrical parts must be considered as *live*.
- The manipulator can move unexpectedly at any time.



#### **DANGER**

Troubleshooting on the controller while powered on must be performed by personnel trained by ABB or by ABB field engineers.

A risk assessment must be done to address both robot and robot system specific hazards.



#### **WARNING**

Hazards due to the use of brake release devices and/or gravity beneath the manipulator shall be considered.

A robot may perform unexpected limited movement.



#### **WARNING**

Manipulator movements can cause serious injuries on users and may damage equipment.

### Related information

See also the safety information related to installation, operation, maintenance, and repair.

# 1 Safety

---

## 1.8 Safety during decommissioning

### 1.8 Safety during decommissioning

---

#### General

See section [Decommissioning on page 379](#).

If the robot is decommissioned for storage, take extra precaution to reset safety devices to delivery status.

---

#### Unexpected movement of robot arm



#### WARNING

Hazards due to the use of brake release devices and/or gravity beneath the manipulator shall be considered.

A robot may perform unexpected limited movement.



#### WARNING

Manipulator movements can cause serious injuries on users and may damage equipment.

## 2 Installation and commissioning

### 2.1 Introduction to installation and commissioning

#### General

This chapter contains assembly instructions and information for installing the IRB 910SC at the working site.

See also the product manual for the robot controller.

The installation must be done by qualified installation personnel in accordance with the safety requirements set forth in the applicable national and regional standards and regulations.

The technical data is detailed in section [Technical data on page 41](#).

#### Safety information

Before any installation work is commenced, all safety information must be observed. There are general safety aspects that must be read through, as well as more specific safety information that describes the danger and safety risks when performing the procedures. Read the chapter [Safety on page 17](#) before performing any installation work.



#### Note

Always connect the IRB 910SC and the robot to protective earth and residual current device (RCD) before connecting to power and starting any installation work.

For more information see:

- *Product manual - IRC5 Compact*

## 2 Installation and commissioning

### 2.2.1 Pre-installation procedure

## 2.2 Unpacking

### 2.2.1 Pre-installation procedure

#### Introduction

This section is intended for use when unpacking and installing the robot for the first time. It also contains information useful during later re-installation of the robot.

#### Prerequisites for installation personnel

Installation personnel working with an ABB product must:

- be trained by ABB and have the required knowledge of mechanical and electrical installation/maintenance/repair work
- conform to all national and local codes.

#### Checking the pre-requisites for installation

	Action
1	Make a visual inspection of the packaging and make sure that nothing is damaged.
2	Remove the packaging.
3	Check for any visible transport damage.  <b>Note</b> Stop unpacking and contact ABB if transport damages are found.
4	Clean the unit with a lint-free cloth, if necessary.
5	Make sure that the lifting accessory used (if required) is suitable to handle the weight of the robot as specified in: <a href="#">Weight, robot on page 41</a>
6	If the robot is not installed directly, it must be stored as described in: <a href="#">Storage conditions, robot on page 43</a>
7	Make sure that the expected operating environment of the robot conforms to the specifications as described in: <a href="#">Operating conditions, robot on page 43</a>
8	Before taking the robot to its installation site, make sure that the site conforms to: <ul style="list-style-type: none"><li>• <a href="#">Loads on foundation, robot on page 42</a></li><li>• <a href="#">Protection classes, robot on page 44</a></li><li>• <a href="#">Requirements, foundation on page 43</a></li></ul>
9	Before moving the robot, please observe the stability of the robot: <a href="#">Risk of tipping/stability on page 51</a>
10	When these prerequisites are met, the robot can be taken to its installation site as described in section: <a href="#">On-site installation on page 54</a>
11	Install required equipment, if any.

## 2.2.2 Technical data

### Weight, robot

The table shows the weight of the robot.

Robot model	Weight
IRB 910SC	IRB 910SC-3/0.45: 24.5 kg
	IRB 910SC-3/0.55: 25 kg
	IRB 910SC-3/0.65: 25.5 kg



#### Note

The weight does not include tools and other equipment fitted on the robot.

### Mounting positions

The table shows valid mounting options for the manipulator.

Mounting option	Installation angle	Note
Floor mounted	0°	



#### Note

The actual mounting angle must always be configured in the system parameters, otherwise the performance and lifetime is affected. For details, see *Technical reference manual - System parameters*.

*Continues on next page*

## 2 Installation and commissioning

### 2.2.2 Technical data

Continued

#### Loads on foundation, robot

The illustration shows the directions of the robots stress forces.

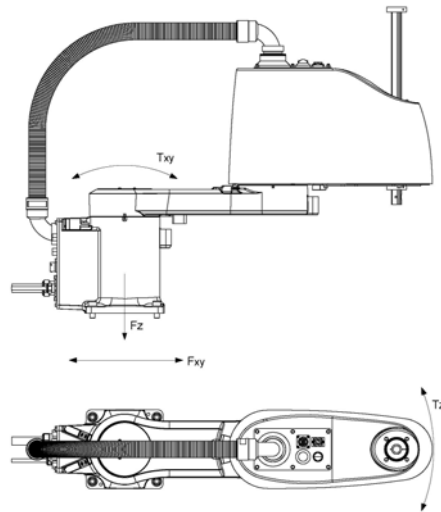

xx1500002522

$F_{xy}$	Force in any direction in the XY plane
$F_z$	Force in the Z plane
$T_{xy}$	Bending torque in any direction in the XY plane
$T_z$	Bending torque in the Z plane

The table shows the various forces and torques working on the robot during different kinds of operation.



#### Note

These forces and torques are extreme values that are rarely encountered during operation. The values also never reach their maximum at the same time!



#### WARNING

The robot installation is restricted to the mounting options given in following load table(s).

#### Floor mounted

Force	Endurance load (in operation)	Max. load (emergency stop)
Force xy	±651 N	±945 N
Force z	255±392 N	255±441 N
Torque xy	±260 Nm	±418 Nm
Torque z	±121 Nm	±238 Nm

Continues on next page

#### Requirements, foundation

The table shows the requirements for the foundation where the weight of the installed robot is included:

Requirement	Value	Note
Flatness of foundation surface	0.1/500 mm	Flat foundations give better repeatability of the resolver calibration compared to original settings on delivery from ABB. The value for levelness aims at the circumstance of the anchoring points in the robot base. In order to compensate for an uneven surface, the robot can be recalibrated during installation. If resolver/encoder calibration is changed this will influence the absolute accuracy.
Minimum resonance frequency	22 Hz  <b>Note</b> It may affect the manipulator life-time to have a lower resonance frequency than recommended.	The value is recommended for optimal performance. Due to foundation stiffness, consider robot mass including equipment. <sup>i</sup> For information about compensating for foundation flexibility, see the application manual of the controller software, section <i>Motion Process Mode</i> .

<sup>i</sup> The minimum resonance frequency given should be interpreted as the frequency of the robot mass/inertia, robot assumed stiff, when a foundation translational/torsional elasticity is added, i.e., the stiffness of the pedestal where the robot is mounted. The minimum resonance frequency should not be interpreted as the resonance frequency of the building, floor etc. For example, if the equivalent mass of the floor is very high, it will not affect robot movement, even if the frequency is well below the stated frequency. The robot should be mounted as rigid as possibly to the floor.  
Disturbances from other machinery will affect the robot and the tool accuracy. The robot has resonance frequencies in the region 10 – 20 Hz and disturbances in this region will be amplified, although somewhat damped by the servo control. This might be a problem, depending on the requirements from the applications. If this is a problem, the robot needs to be isolated from the environment.

#### Storage conditions, robot

The table shows the allowed storage conditions for the robot:

Parameter	Value
Minimum ambient temperature	-25 °C
Maximum ambient temperature	55 °C
Maximum ambient temperature (less than 24 hrs)	70 °C
Maximum ambient humidity	95% at constant temperature (gaseous only)

#### Operating conditions, robot

The table shows the allowed operating conditions for the robot:

Parameter	Value
Minimum ambient temperature	5 °C <sup>i</sup>
Maximum ambient temperature	45 °C
Maximum ambient humidity	95% at constant temperature

<sup>i</sup> At low environmental temperature < 10 °C is, as with any other machine, a warm-up phase recommended to be run with the robot. Otherwise there is a risk that the robot stops or run with lower performance due to temperature dependent oil and grease viscosity.

*Continues on next page*

## 2 Installation and commissioning

---

### 2.2.2 Technical data

*Continued*

---

#### Protection classes, robot

The table shows the available protection types of the robot, with the corresponding protection class.

Protection type	Protection class <sup>i</sup>
Manipulator, protection type Standard	IP20

<sup>i</sup> According to IEC 60529.



2.2.3 Dimensions

Dimensions IRB 910SC

The figure shows the dimension of the robot.

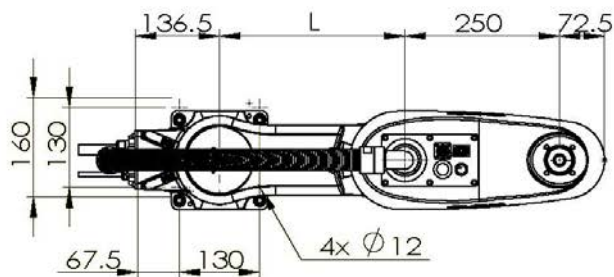
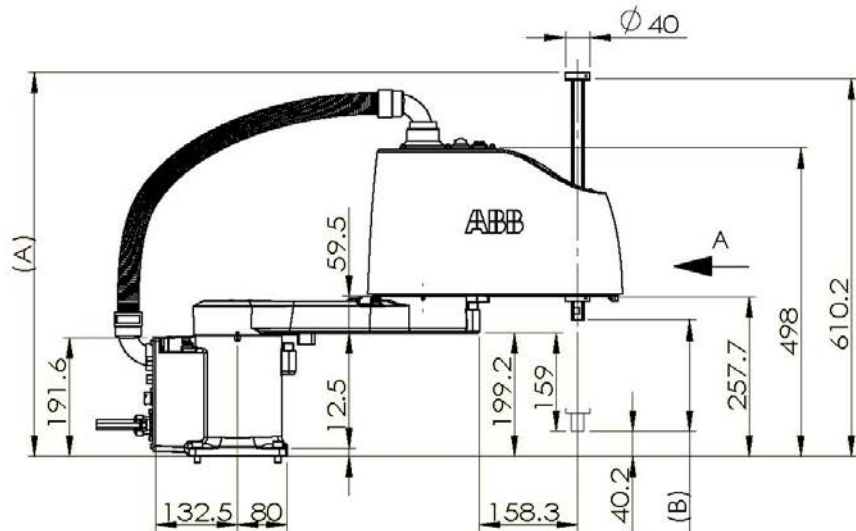
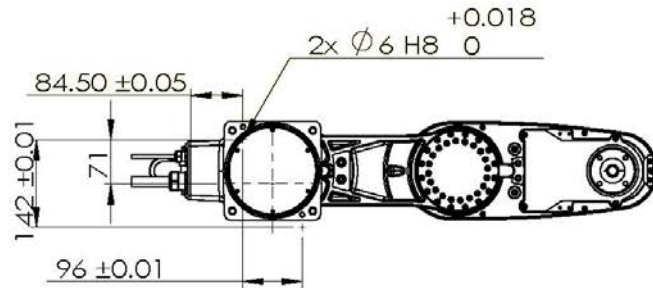

xx1500002526

Continues on next page

## 2 Installation and commissioning

---

### 2.2.3 Dimensions

*Continued*

Item	Description	Variant		
		IRB 910SC-3/0.45	IRB 910SC-3/0.55	IRB 910SC-3/0.65
L	Length of lower arm	200 mm	300 mm	400 mm
A	Maximum height	620 mm	620 mm	620 mm
B	Z stroke	180 mm	180 mm	180 mm

2.2.4 Working range

Illustration, working range and turning radius IRB 910SC-3/0.45

This illustration shows the unrestricted working range and turning radius of IRB 910SC-3/0.45.

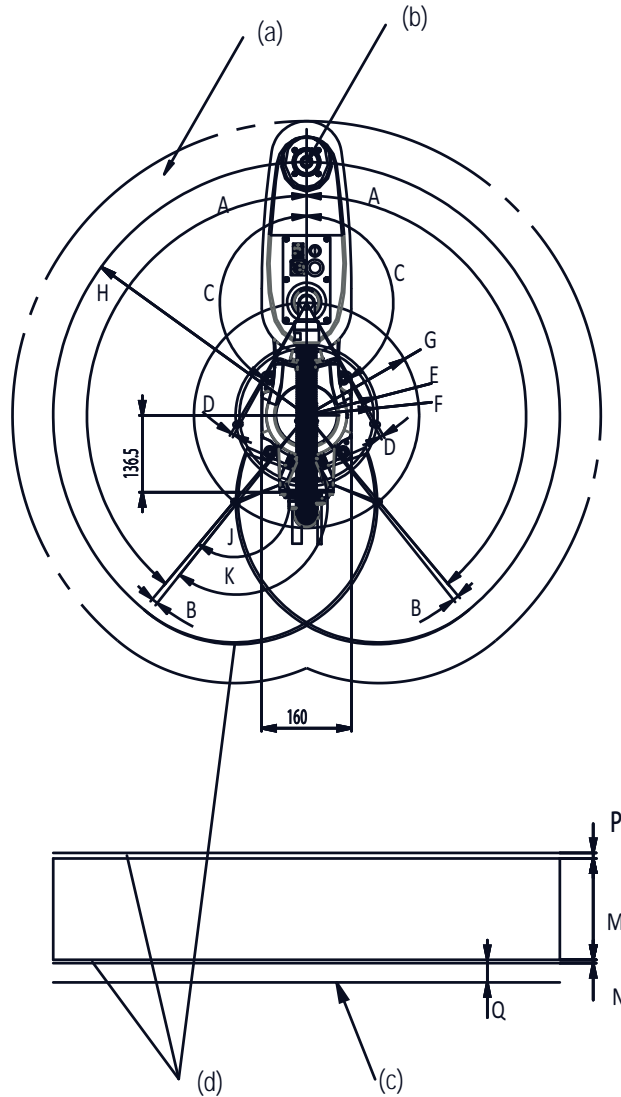

xx1500002474

a	Maximum space	F	119 mm
b	Center joint of axis 3	G	200 mm
c	Base mounting face	H	450 mm
d	Area limited by mechanical stop	J	150°
A	140°	K	151.2°
B	1.5°	M	180 mm
C	150°	N	5 mm
D	1.2°	P	2 mm

Continues on next page

## 2 Installation and commissioning

### 2.2.4 Working range

Continued

E	126 mm	Q	40.2 mm
---	--------	---	---------

#### Illustration, working range and turning radius IRB 910SC-3/0.55

This illustration shows the unrestricted working range and turning radius of IRB 910SC-3/0.55.

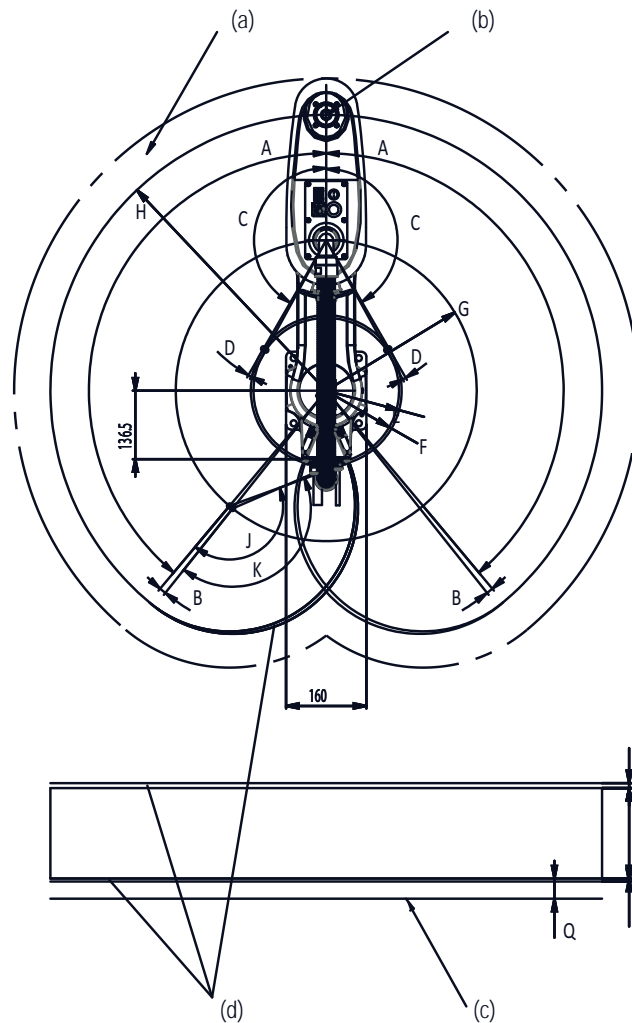

xx1500002475

a	Maximum space	F	145 mm
b	Center joint of axis 3	G	300 mm
c	Base mounting face	H	550 mm
d	Area limited by mechanical stop	J	150°
A	140°	K	151.2°
B	1.5°	M	180 mm
C	150°	N	5 mm
D	1.2°	P	2 mm
E	150 mm	Q	40.2 mm

Continues on next page

#### Illustration, working range and turning radius IRB 910SC-3/0.65

This illustration shows the unrestricted working range and turning radius of IRB 910SC-3/0.65.

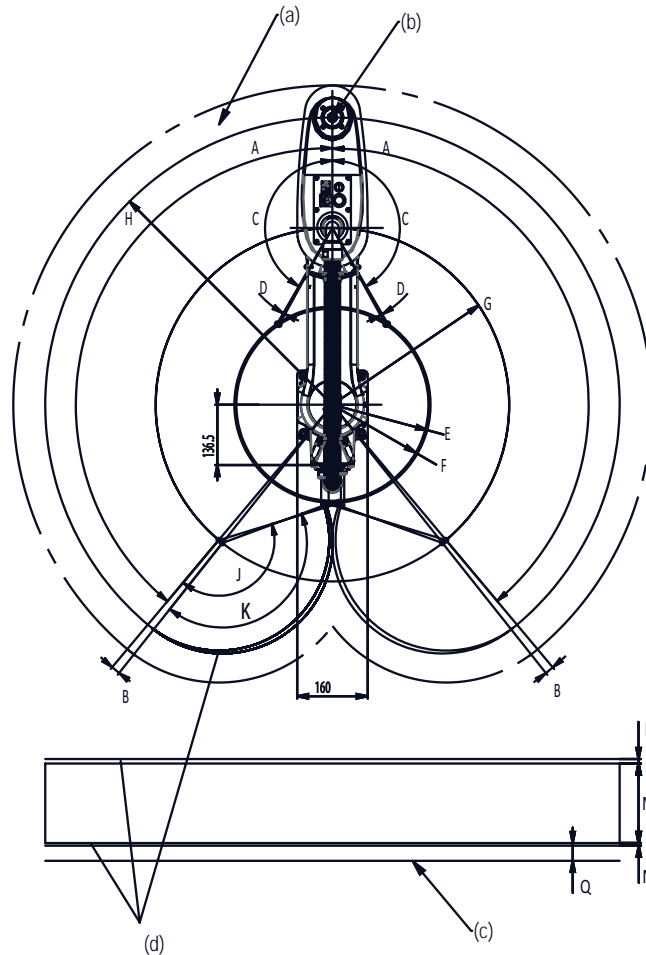

xx1500002476

a	Maximum space	F	217 mm
b	Center joint of axis 3	G	400 mm
c	Base mounting face	H	650 mm
d	Area limited by mechanical stop	J	150°
A	140°	K	151.2°
B	1.5°	M	180 mm
C	150°	N	5 mm
D	1.2°	P	2 mm
E	222 mm	Q	40.2 mm

#### Working range

Axis	Type of motion	Working range
Axis 1	Rotation motion	-140° to +140°

Continues on next page

## 2 Installation and commissioning

---

### 2.2.4 Working range

*Continued*

Axis	Type of motion	Working range
Axis 2	Rotation motion	-150° to +150° <sup>i</sup>
Axis 3	Linear motion	-180 mm to 0 mm
Axis 4	Rotation motion	Default: -400° to +400° <sup>ii</sup>

<sup>i</sup> The axis 2 can be restricted to a smaller working range by fitting one more axis-2 mechanical stop block to the upper arm. For how to fit the block, see [Replacing the axis-2 mechanical stop block on page 275](#).

The additional mechanical stop block and related screws are provided in accessory package.

<sup>ii</sup> The default working range for axis 4 can be extended by changing parameter values in the software.

#### 2.2.5 Risk of tipping/stability

##### Risk of tipping

If the robot is not fastened to the foundation while moving the arm, the robot is not stable in the whole working area. Moving the arm will displace the center of gravity, which may cause the robot to tip over.

The transportation position is the most stable position.

**Do not change the robot position before securing it to the foundation!**

##### Transportation position

This figure shows the robot in its transportation position.

IRB 910SC-3/0.45

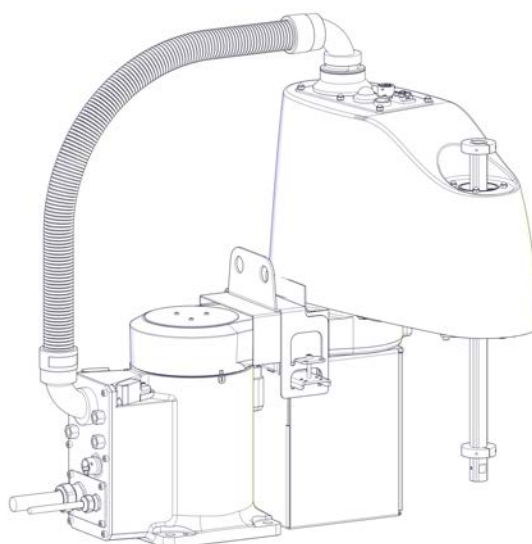

xx150002487

*Continues on next page*

## 2 Installation and commissioning

### 2.2.5 Risk of tipping/stability

Continued

IRB 910SC-3/0.55 and IRB 910SC-3/0.65

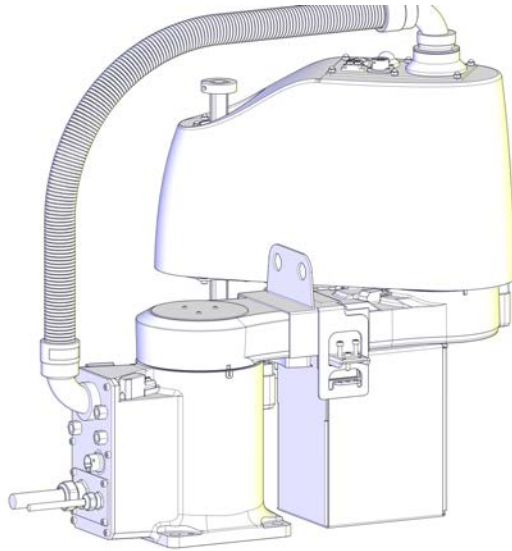

xx1500002492

Axis number	Angle of axis
Axis 1	0°
Axis 2	IRB 910SC-3/0.45: -90° IRB 910SC-3/0.55: +130° IRB 910SC-3/0.65: +130°
Axis 3	0 mm
Axis 4	0°



#### Note

The robot might be positioned in a different position at delivery, due to actual configurations and options (for example DressPack).



#### WARNING

The robot will be mechanically unstable if not properly secured to the foundation.



### 2.2.6 The unit is sensitive to ESD

---

#### Description

ESD (electrostatic discharge) is the transfer of electrical static charge between two bodies at different potentials, either through direct contact or through an induced electrical field. When handling parts or their containers, personnel not grounded may potentially transfer high static charges. This discharge may destroy sensitive electronics.

#### Safe handling

Use one of the following alternatives:

- Use a wrist strap.

Wrist straps must be tested frequently to ensure that they are not damaged and are operating correctly.

- Use an ESD protective floor mat.

The mat must be grounded through a current-limiting resistor.

- Use a dissipative table mat.

The mat should provide a controlled discharge of static voltages and must be grounded.

## 2 Installation and commissioning

### 2.3.1 Lifting robot with lifting accessories

## 2.3 On-site installation

### 2.3.1 Lifting robot with lifting accessories

#### Introduction

IRB 910SC-3/0.45

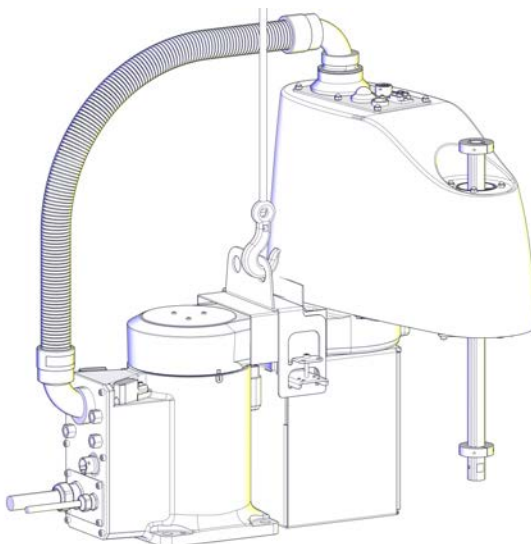

xx1500002472

IRB 910SC-3/0.55 and IRB 910SC-3/0.65

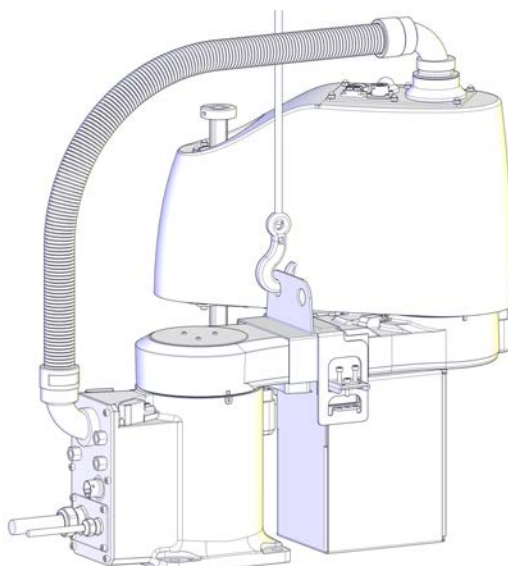

xx1500002473

#### Required equipment

Equipment	Article number	Note
Overhead crane	-	

*Continues on next page*

## 2 Installation and commissioning

### 2.3.1 Lifting robot with lifting accessories

*Continued*

Equipment	Article number	Note
Lifting chain	-	> 50 kg (capacity of lifting chain)
Hook	-	
Lifting accessory, robot	-	Includes lifting accessories and screws.

#### Lifting the robot

Use this procedure to lift the robot.

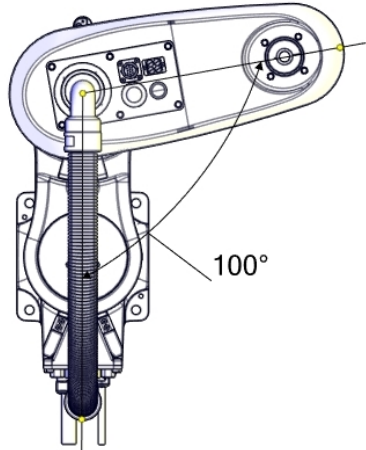
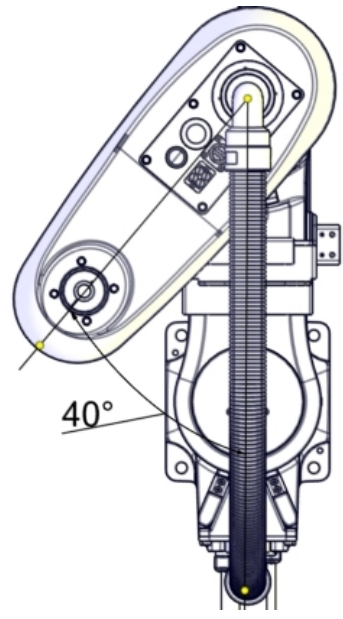

	Action	Note
1	<p>Move the robot to the appropriate lifting position.</p> <p> <b>WARNING</b></p> <p>The robot is likely to be mechanically unstable if not secured to the foundation!</p>	<p>Valid for IRB 910SC-3/0.45</p>  <p>100°</p> <p>xx1500002483</p> <p>Valid for IRB 910SC-3/0.55 and IRB 910SC-3/0.65</p>  <p>40°</p> <p>xx1500002488</p>

*Continues on next page*

## 2 Installation and commissioning

### 2.3.1 Lifting robot with lifting accessories

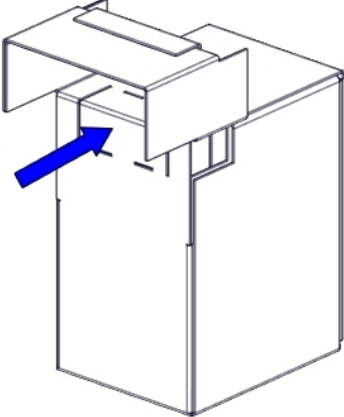
Continued

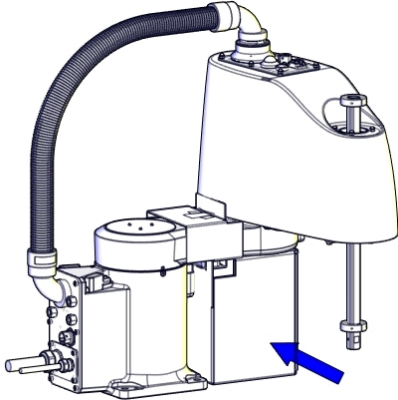
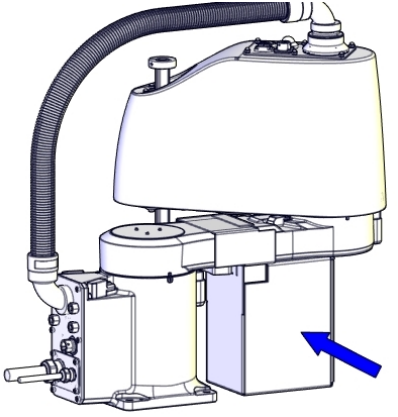
	Action	Note
2	<p>Fold the lifting paper box to the required shape and put it to the proper position under the lower arm.</p>  <p>xx1500002493</p> <p> <b>Note</b></p> <p>For the IRB 910SC-3/0.45, fold the part pointing out in the figure along the folding mark so that a space will be left for the axis-1 mechanical stop block.</p>	<p>Valid for IRB 910SC-3/0.45</p>  <p>xx1500002484</p> <p>Valid for IRB 910SC-3/0.55 and IRB 910SC-3/0.65</p>  <p>xx1500002489</p>

Continues on next page

## 2 Installation and commissioning

### 2.3.1 Lifting robot with lifting accessories

*Continued*

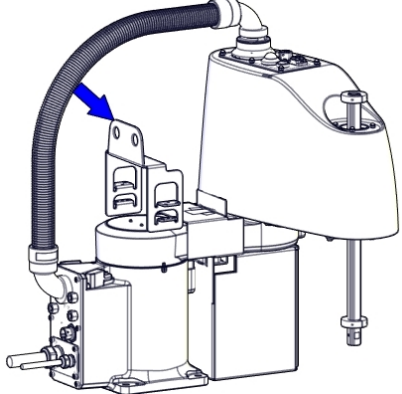
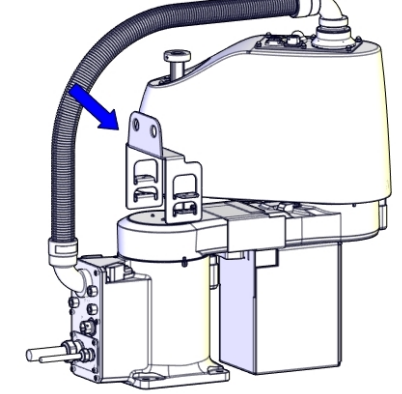
	Action	Note
3	Fit the lifting bracket.	<p data-bbox="1023 315 1326 342">Valid for IRB 910SC-3/0.45</p>  <p data-bbox="1023 752 1129 770">xx1500002485</p> <p data-bbox="1023 790 1422 842">Valid for IRB 910SC-3/0.55 and IRB 910SC-3/0.65</p>  <p data-bbox="1023 1256 1129 1274">xx1500002490</p>

*Continues on next page*

## 2 Installation and commissioning

### 2.3.1 Lifting robot with lifting accessories

Continued

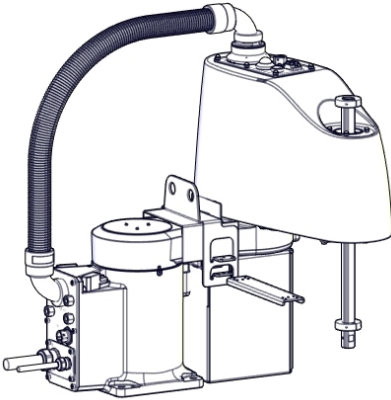
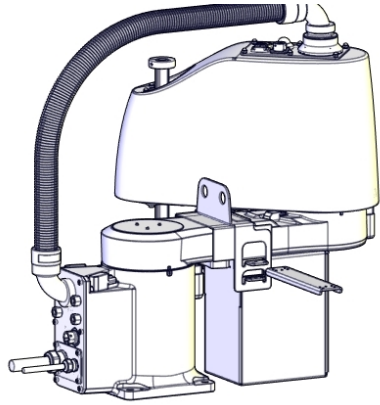

	Action	Note
4	<p>Insert the metal plate through the bracket and the paper box.</p> <p> <b>Note</b></p> <p>IRB 910SC-3/0.45: Use lower lug on the bracket.</p> <p>IRB 910SC-3/0.55 and IRB 910SC-3/0.65: Use upper lug on the bracket.</p>	<p>Valid for IRB 910SC-3/0.45</p>  <p>xx1500002771</p> <p>Valid for IRB 910SC-3/0.55 and IRB 910SC-3/0.65</p>  <p>xx1500002772</p>

Continues on next page

## 2 Installation and commissioning

### 2.3.1 Lifting robot with lifting accessories

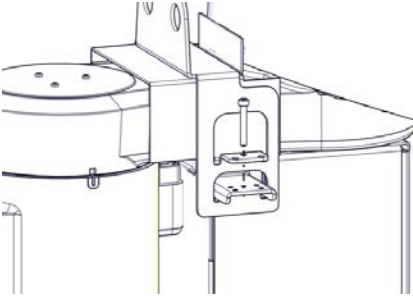
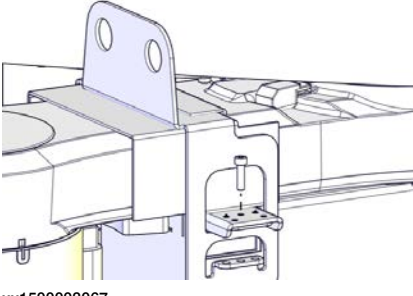
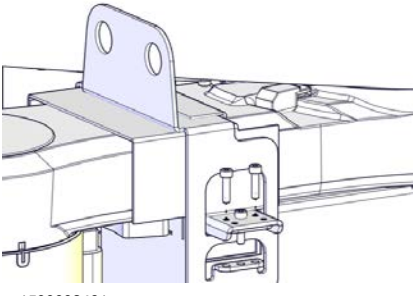
*Continued*

	Action	Note
5	<p>Secure the metal plate with screw(s).            IRB 910SC-3/0.45: One screw at each side.            IRB 910SC-3/0.55 and IRB 910SC-3/0.65: One screw at one side only.</p>	<p><b>Valid for IRB 910SC-3/0.45</b></p>  <p>xx1500002486</p> <p><b>Screw: M4x30 (2 pcs)</b>  <b>Tightening torque: 0.3-0.4 Nm</b></p> <p><b>Valid for IRB 910SC-3/0.55 and IRB 910SC-3/0.65</b></p>  <p>xx1500003067</p> <p><b>Screw: M4x12 (1 pcs)</b>  <b>Tightening torque: 0.2-0.3 Nm</b></p>
6	<p><b>For IRB 910SC-3/0.55 and IRB 910SC-3/0.65</b>            Fasten two screws at each side to clamp the metal plate and the bracket.</p>	<p><b>Screw: M4x12 (4 pcs)</b>  <b>Tightening torque: 0.2-0.3 Nm</b></p>  <p>xx1500002491</p>
7	<p> <b>CAUTION</b></p> <p>The IRB 910SC robot weighs 25.5 kg at a maximum.            All lifting accessories used must be sized accordingly!</p>	
8	<p> <b>WARNING</b></p> <p>Personnel must not, under any circumstances, be present under the suspended load!</p>	

*Continues on next page*

## 2 Installation and commissioning

### 2.3.1 Lifting robot with lifting accessories

Continued

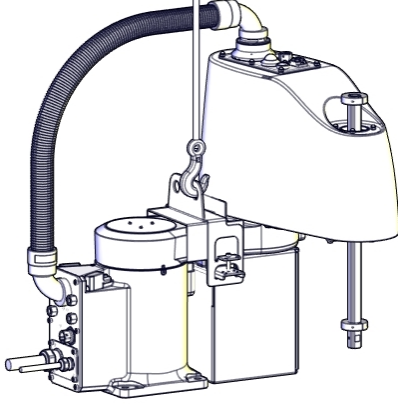
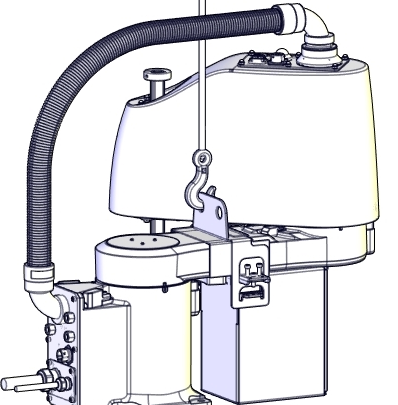
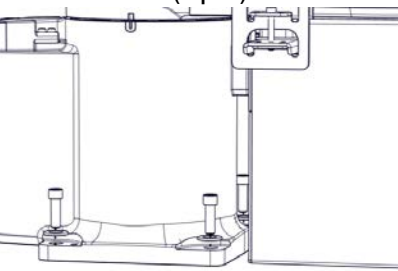
	Action	Note
9	Attach the lifting chain to the robot.	<p>Lifting capacity for the lifting chain is specified in <a href="#">Required equipment on page 54</a>.</p> <p>Valid for IRB 910SC-3/0.45</p>  <p>xx1500002495</p> <p>Valid for IRB 910SC-3/0.55 and IRB 910SC-3/0.65</p>  <p>xx1500002494</p>
10	<p>Carefully stretch the chain by lifting the crane slowly.</p> <p>This prevents the robot from falling down when it is unfastened or the support is removed. Do not overstretch the chain if the robot is fastened because there is a risk of the robot being damaged.</p>	
11	Remove the robot attachment screws (if the robot is fastened).	<p>Screw: M10x25 (4 pcs)</p>  <p>xx1500002773</p>

Continues on next page



## 2 Installation and commissioning

---

### 2.3.1 Lifting robot with lifting accessories

*Continued*

	Action	Note
12	Raise the overhead crane to lift the robot.	

## 2 Installation and commissioning

### 2.3.2 Manually releasing the brakes

### 2.3.2 Manually releasing the brakes

#### Introduction to manually releasing the brakes

This section describes how to release the holding brakes for the motors of each axis.

#### Location of brake release unit

The internal brake release unit is located as shown in the figure.

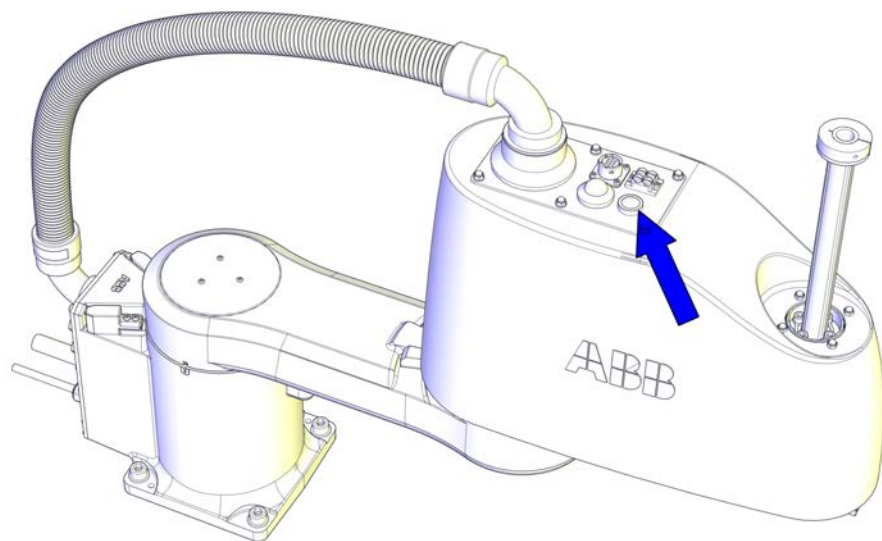

xx1500002173

#### Releasing the brakes

This procedure details how to release the holding brakes when the robot is equipped with an internal brake release unit.

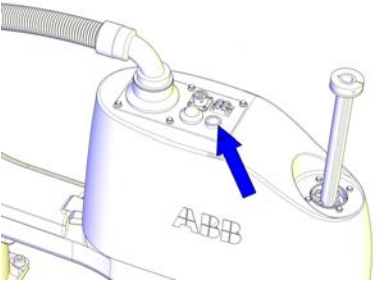

	Action	Note
1	The internal brake release unit is equipped with a button for controlling the axes brakes. If the robot is not connected to the controller, power must be supplied to the connector R1.MP according to the section <a href="#">Supplying power to connector R1.MP on page 63</a> .	 <p>xx1500002774</p>

Continues on next page

	Action	Note
2	 <b>DANGER</b> When releasing the holding brakes, the robot axes may move very quickly and sometimes in unexpected ways! Make sure the payload is disassembled or tooling is properly supported; otherwise, fast downward movements of axis 3 may cause severe hits.	
3	Release the holding brake on all robot axes by pressing the button on the internal brake release unit. The brake will function again as soon as the button is released.	

#### Supplying power to connector R1.MP

If the robot is not connected to the controller, power must be supplied to connector R1.MP on the robot in order to enable the brake release buttons.

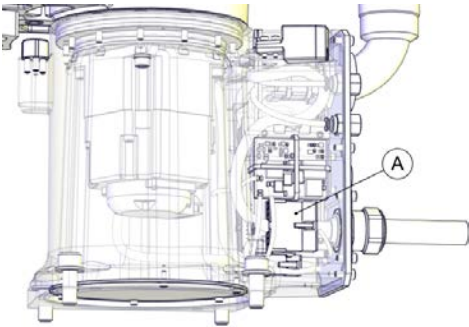
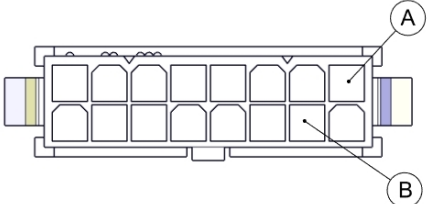
	Action	Note						
1	 <b>DANGER</b> Incorrect connections, such as supplying power to the wrong pin, may cause all brakes to be released simultaneously!							
2	Supply +24V on pin 15 and 0V on pin 8.  <b>Note</b> Do not interchange the 24V and 0V pins. If they are mixed up, damage can be caused to the brake release unit and to the system board.	 <p>xx1500002477</p> <table border="1"> <tr> <td>A</td> <td>R1.MP</td> </tr> </table>  <p>xx1500002478</p> <table border="1"> <tr> <td>A</td> <td>0V (8)</td> </tr> <tr> <td>B</td> <td>+24V (15)</td> </tr> </table>	A	R1.MP	A	0V (8)	B	+24V (15)
A	R1.MP							
A	0V (8)							
B	+24V (15)							

## 2 Installation and commissioning

### 2.3.3 Orienting and securing the robot

### 2.3.3 Orienting and securing the robot

#### Introduction

This section details how to orient and secure the robot to the foundation or base plate in order to run the robot safely. The requirements made on the foundation are shown in sections:

- [Loads on foundation, robot on page 42](#)
- [Requirements, foundation on page 43.](#)

#### Hole configuration, base

The illustration shows the hole configuration used when securing the robot.

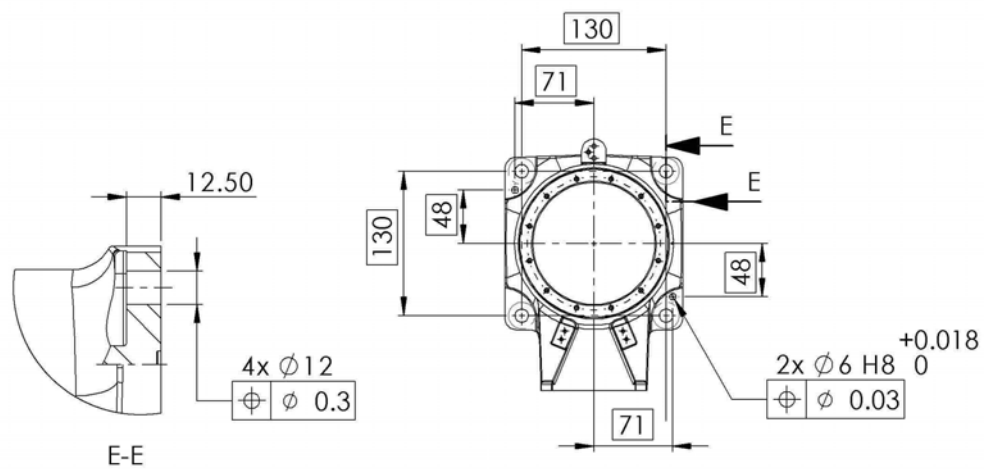

xx1500002521

#### Specification, attachment screws and pins

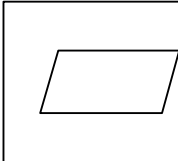

The table specifies the type of securing screws and washers to be used to secure the robot directly to the foundation. It also specifies the type of pins to be used.

Suitable screws	M10x25
Quantity	4 pcs
Quality	8.8
Suitable washer	20x10.5x2
Guide pins	2 pcs, D6x20, ISO 2338 - 6m6x20 - A1
Tightening torque	45 Nm
Level surface requirements	<div style="display: flex; align-items: center; justify-content: center;">  <div style="margin-left: 20px; font-size: 24px; font-weight: bold;">0.1</div> </div> <p style="font-size: 8px; margin-top: 5px;">xx1500000627</p>

*Continues on next page*

#### Orienting and securing the robot

Use this procedure to orient and secure the robot.

	Action	Information
1	Make sure the installation site for the robot conforms to the specifications in section: <ul style="list-style-type: none"> <li>• <a href="#">Pre-installation procedure on page 40.</a></li> </ul>	
2	Prepare the installation site with attachment holes.	The hole configuration of the base is shown in the figure in <a href="#">Hole configuration, base on page 64.</a>
3	 <b>CAUTION</b> The IRB 910SC robot weighs 25.5 kg at a maximum. All lifting accessories used must be sized accordingly!	
4	 <b>CAUTION</b> When the robot is put down after being lifted or transported, there is a risk of it tipping, if not properly secured.	
5	Lift the robot to its installation site.	See <a href="#">Lifting robot with lifting accessories on page 54.</a>
6	Fit two pins to the holes in the base.	2 pcs, D6x20, ISO 2338 - 6m6x20 - A1
7	Guide the robot gently, using the attachment screws while lowering it into its mounting position.	Make sure the robot base is correctly fitted onto the pins.
8	Fit the securing screws and washers in the attachment holes of the base.	Screws: M10x25, quality: 8.8
9	Tighten the bolts in a criss-cross pattern to ensure that the base is not distorted.	Tightening torque: 45 Nm

#### Securing robot on a mounting plate

When bolting a mounting plate or frame to a concrete floor, follow the general instructions for expansion-shell bolts.

Screw joints must be able to withstand the stress loads defined in section [Loads on foundation, robot on page 42.](#)

## 2 Installation and commissioning

---

### 2.3.4 Loads fitted to the robot, stopping time and braking distances

### 2.3.4 Loads fitted to the robot, stopping time and braking distances

---

#### General

Any loads mounted on the robot must be defined correctly and carefully (with regard to the position of center of gravity and mass moments of inertia) in order to avoid jolting movements and overloading motors, gears and structure.



#### CAUTION

Incorrectly defined loads may result in operational stops or major damage to the robot.

#### References

Load diagrams, permitted extra loads (equipment) and their positions are specified in the product specification. The loads must be defined in the software.

- *Operating manual - IRC5 with FlexPendant*

#### Stopping time and braking distances

The performance of the motor brake depends on if there are any loads attached to the robot. For more information, see product specification listed in [References on page 10](#).

#### 2.3.5 Fitting equipment on the robot

##### Fitting of end effector to the ball screw spline shaft

An end effector can be attached to the lower end of the shaft of the ball screw spline unit. The dimensions for fitting the end effector is shown in the following figure.



##### Note

Mounting of other equipment on the IRB 910SC may damage the gearboxes.

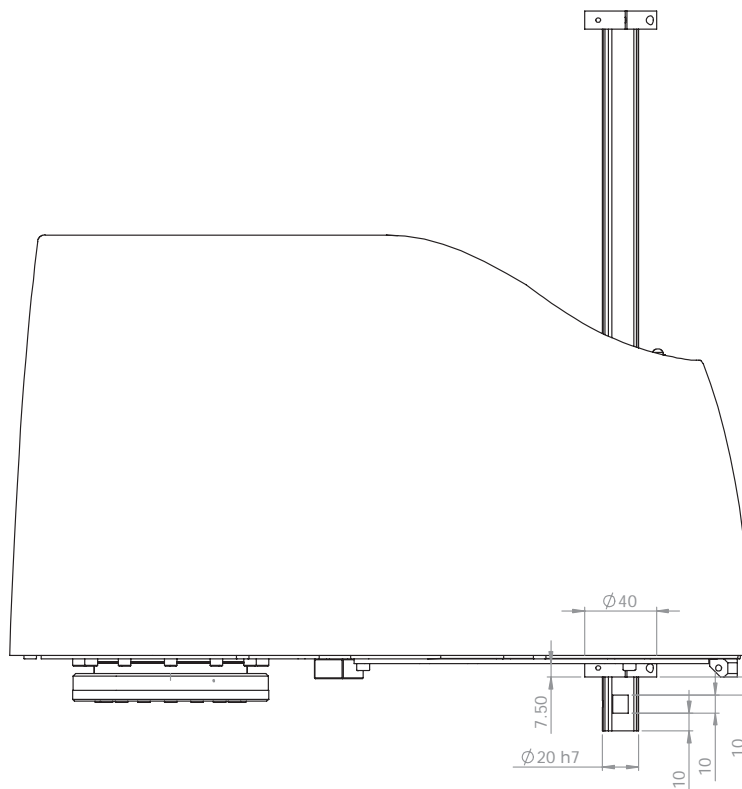

xx1700001187

*Continues on next page*

## 2 Installation and commissioning

### 2.3.5 Fitting equipment on the robot

Continued

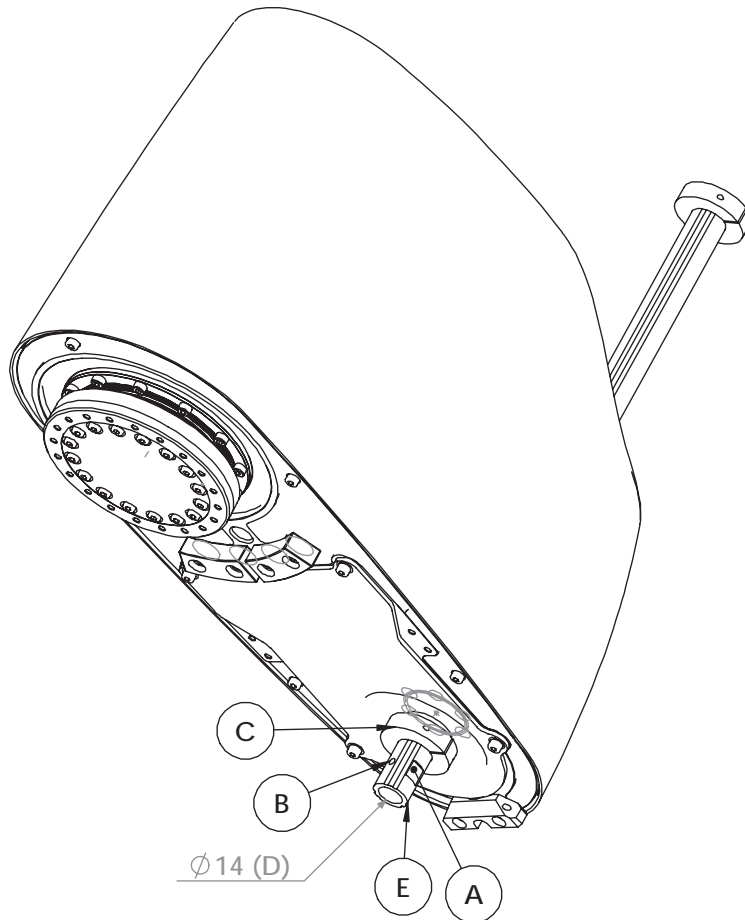

xx1500002523

A	Flat cut
B	Conical hole
C	Stop block diameter
D	Through hole
E	Shaft diameter

#### Fastener quality

When fitting tools on the tool flange, only use screws with quality 12.9. For other equipment use suitable screws and tightening torque for your application.



## 2.4 Restricting the working range

### 2.4.1 Axes with restricted working range

#### General

When installing the robot, make sure that it can move freely within its entire working space. If there is a risk that it may collide with other objects, its working space should be limited.

The working range of the following axes may be restricted:

- Axis 1, hardware (mechanical stop)
- Axis 2, hardware (mechanical stop)
- Axes 3 and 4, hardware (stop block)

This section describes how to install hardware that restricts the working range.



#### Note

Adjustments must also be made in the robot configuration software (system parameters). References to relevant manuals are included in the installation procedures.

## 2 Installation and commissioning

### 2.4.2 Mechanically restricting the working range

#### 2.4.2 Mechanically restricting the working range

##### Location of mechanical stops

The figures shows where the mechanical stops are placed on the robot.

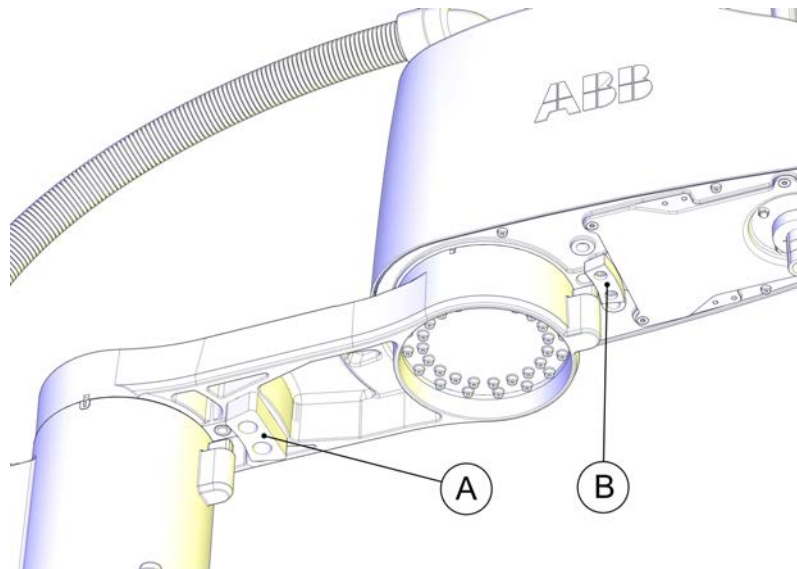

xx1500002811

A	Mechanical stop block, axis 1 (lower arm)
B	Mechanical stop block, axis 2 (upper arm)

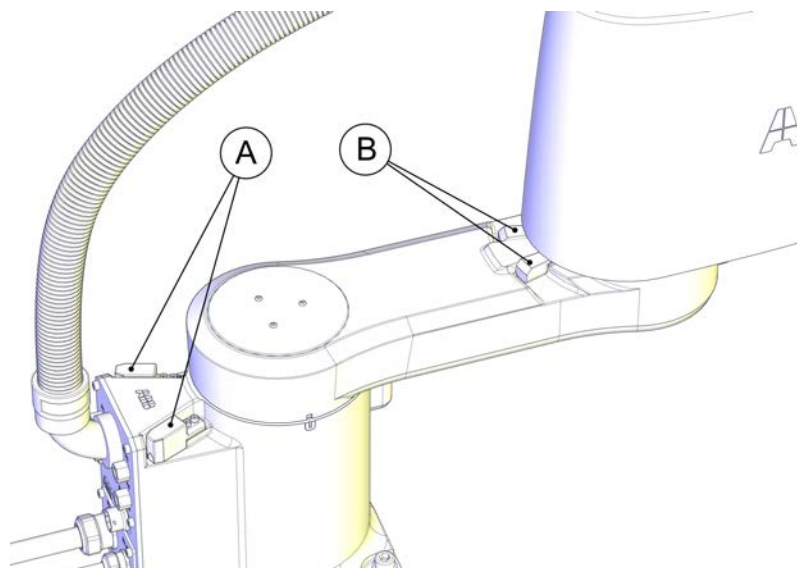

xx1500002814

A	Mechanical stop rubbers, axis 1 (base)
B	Mechanical stop rubbers, axis 2 (lower arm)

*Continues on next page*

## 2 Installation and commissioning

### 2.4.2 Mechanically restricting the working range

*Continued*

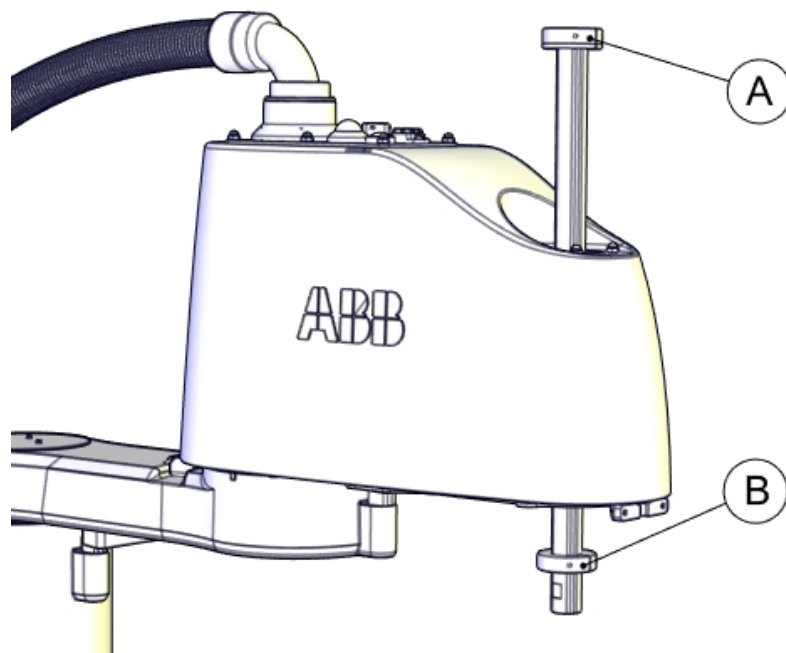

xx1500002813

A	Upper stop block, axes 3 and 4 (upper arm)
B	Lower stop block, axes 3 and 4 (upper arm)

## 2 Installation and commissioning

### 2.5.1 Robot cabling and connection points

## 2.5 Electrical connections

### 2.5.1 Robot cabling and connection points

#### Introduction

Connect the robot and controller to each other after securing them to the foundation. The lists below specify which cables to use for each respective application. IRB 910SC works with IRC5 Compact controller only.

#### Main cable categories

All cables between the robot and controller are divided into the following categories:

Cable category	Description
Robot cables	Handles power supply to and control of the robot's motors as well as feedback from the encoder interface board. Specified in the table <a href="#">Robot cables on page 72</a> .
Customer cables (option)	Handles communication with equipment fitted on the robot by the customer (low voltage signals). The customer cables also handle Ethernet communication. See <i>Product manual - IRC5 Compact</i> .

#### Robot cables

These cables are included in the standard delivery. They are completely pre-manufactured and ready to plug in.

Cable sub-category	Description	Connection point, cabinet	Connection point, robot
Robot cable, power	Transfers drive power from the drive units in the control cabinet to the robot motors.	XS1	R1.MP
Robot cable, signals	Transfers encoder data from and power supply to the encoder interface board.	XS2	R1.EIB

#### Robot cable, power

Power cable length	Article number
3 m	3HAC057784-001
7 m	3HAC057785-001
15 m	3HAC057786-001

#### Robot cable, signals

Signal cable length	Article number
3 m	3HAC057787-001
7 m	3HAC057788-001
15 m	3HAC057789-001

*Continues on next page*

#### Bending radius for static floor cables

The minimum bending radius is 10 times the cable diameter for static floor cables.

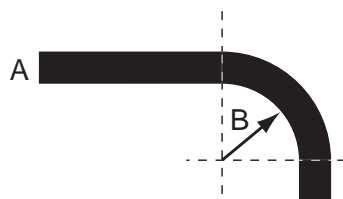

xx1600002016

A	Diameter
B	Diameter x10

#### Grounding and bonding point on manipulator

There is a grounding/bonding point on the manipulator base. The grounding/bonding point is used for potential equalizing between control cabinet, manipulator and any peripheral devices.

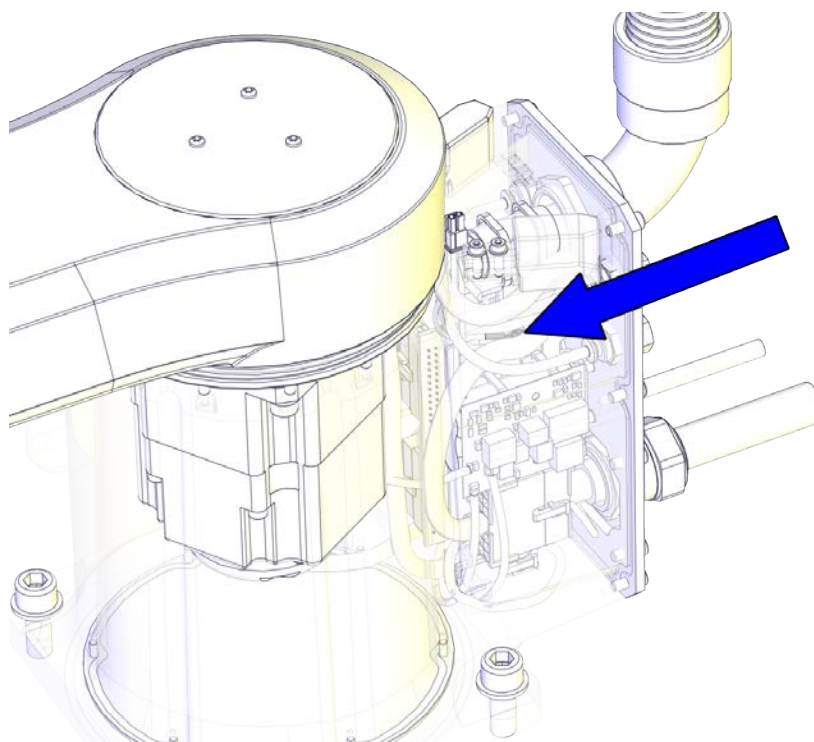

xx2100000706

#### Customer cables - CP/CS cable (option)

CP/CS cable length	Article number
3 m (IRC5C)	3HAC049186-001
7 m (IRC5C)	3HAC049186-004
15 m (IRC5C)	3HAC049186-005

## 2 Installation and commissioning

### 2.5.2 Customer connections

#### 2.5.2 Customer connections

##### Introduction to customer connections

The cables for customer connection are integrated in the robot and the connectors are placed at the upper arm and base. There is one connector R3.CP/CS at the upper arm. Corresponding connector R1.CP/CS is located at the base.

Hose for compressed air is also integrated into the manipulator. There are 4 inlets at the base (R1/8") and 4 outlets (M5) on the upper arm.

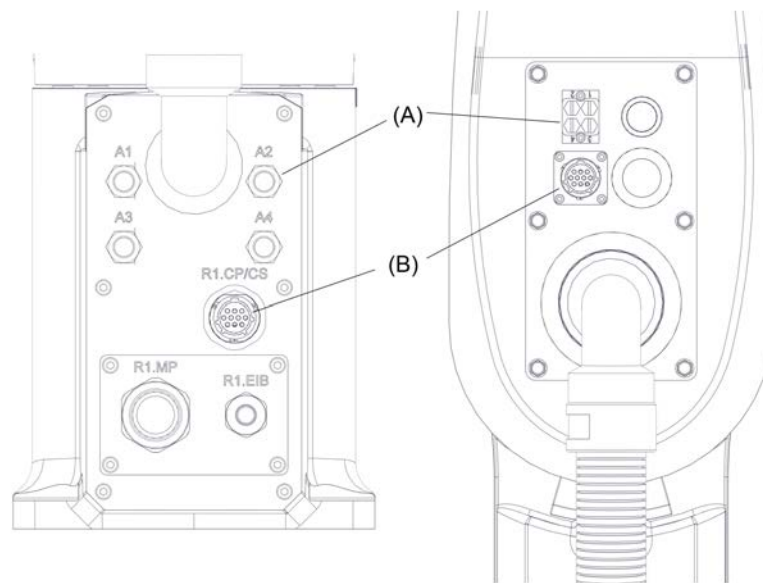

xx1500002751

Position	Connection	Description	Number	Value
A	Air	Max. 5 bar	4	Outer diameter of air hose: 4 mm
B	(R1)R3.CP/CS	Customer power/signal	10	49 V, 500 mA

##### Connectors

The tables describes the connectors on base and upper arm.

##### Connectors, base

Position	Description	Art. no.
Robot	Pin connector 10p, bulkhead	3HAC022117-002
Customer connector	Connector set R1.CP/CS	3HAC037038-001

##### Connectors, upper arm

Position	Description	Art. no.
Robot	Socket connector 10p, flange mounted	3HAC023624-002
Customer connector	Connector set R3.CP/CS	3HAC037070-001

*Continues on next page*

Air, connector

Position	Description	Art. no.
Robot	4xM5	
Customer cable	Air connector	3HAC032049-001

## 2 Installation and commissioning

### 2.6 Start of robot in cold environments

### 2.6 Start of robot in cold environments

#### Introduction

This section describes how to start the robot in a cold environment if it is not starting the normal way.

#### Problems with starting the robot

##### Event message from Motion Supervision

Use this procedure if an event message indicates a problem with Motion supervision at start-up. More information about Motion Supervision is found in *Technical reference manual - System parameters*.

	Action	Note
1	Turn off Motion Supervision.	
2	Start the robot.	
3	When the robot has reached normal working temperature, the Motion Supervision can be turned on again.	

##### Robot stopping with other event message

Use this procedure if the robot is not starting.

	Action	Note
1	Start the robot with its normal program but with reduced speed.	The speed can be regulated with the RAPID instruction <code>VelSet</code> .

#### Adjusting the speed and acceleration during warm-up

Depending on how cold the environment is and what program is being used, the speed might need to be ramped up until reached maximum. The table shows examples of how to adjust the speed:

Work cycles	AccSet	Speed/velocity
3 Work cycles	20, 20	v100 (100 mm/s)
5 Work cycles	40, 40	v400 (400 mm/s)
5 Work cycles	60, 60	v600 (600 mm/s)
5 Work cycles	100, 100	v1000 (1000 mm/s)
More than 5 Work cycles	100, 100	Max.

If the program consists of large wrist movements, it is possible that the reorientation velocity, which is always high in predefined velocities, needs to be included in the ramping up.



## 2.7 Test run after installation, maintenance, or repair

### Safe handling

Use the following procedure after installation, maintenance, or repair, before initiating motion.



#### DANGER

Initiating motion without fulfilling the following aspects, may increase the risk for injury or cause damage to the robot.

	Action
1	Remove all tools and foreign objects from the robot and its working area.
2	Verify that the robot is properly secured to its position by all screws, before it is powered up.
3	Verify that any safety equipment installed to secure the position or restrict the robot motion during service activity is removed.
4	Verify that the fixture and work piece are well secured, if applicable.
5	Verify that all safety equipment is installed, as designed for the application.
6	Verify that no personnel are inside the safeguarded space.
7	If maintenance or repair has been done, verify the function of the part that was maintained.
8	Verify the application in the operating mode manual reduced speed.

### Collision risks



#### CAUTION

When programming the movements of the robot, always identify potential collision risks before initiating motion.

**This page is intentionally left blank**

## 3 Maintenance

### 3.1 Introduction

---

#### Structure of this chapter

This chapter describes all the maintenance activities recommended for the IRB 910SC.

It is based on the maintenance schedule found at the beginning of the chapter. The schedule contains information about required maintenance activities including intervals, and refers to procedures for the activities.

Each procedure contains all the information required to perform the activity, including required tools and materials.

The procedures are gathered in different sections and divided according to the maintenance activity.

---

#### Safety information

Observe all safety information before conducting any service work.

There are general safety aspects that must be read through, as well as more specific safety information that describes the danger and safety risks when performing the procedures. Read the chapter [Safety on page 17](#) before performing any service work.

The maintenance must be done by qualified personnel in accordance with the safety requirements set forth in the applicable national and regional standards and regulations.



#### Note

If the IRB 910SC is connected to power, always make sure that the IRB 910SC is connected to protective earth and a residual current device (RCD) before starting any maintenance work.

For more information see:

- *Product manual - IRC5 Compact*
- [Robot cabling and connection points on page 72.](#)

## 3 Maintenance

---

### 3.2 Service Information System (SIS)

### 3.2 Service Information System (SIS)

---

#### General

Service Information System (SIS) is a software function within the robot controller, which simplifies maintenance of the robot system. It supervises the operating time and mode of the robot, and alerts the operator when a maintenance activity is scheduled.

#### Troubleshooting

The SIS function *Gearbox* is available for estimating the service interval (remaining lifetime) of the gearboxes of a robot. Such information of the ball screw spline unit of the IRB 910SC is reported as **axis 3** in the SIS system. When a service message is reported for axis 3 of the IRB 910SC, an inspection on the ball screw spline unit is required.

For more information about the SIS function, see *Operating manual - Service Information System*.

## 3.3 Maintenance schedule

### 3.3.1 Specification of maintenance intervals

---

#### Introduction

The intervals are specified in different ways depending on the type of maintenance activity to be carried out and the working conditions of the IRB 910SC:

- Calendar time: specified in months regardless of whether the system is running or not.
- Operating time: specified in operating hours. More frequent running means more frequent maintenance activities.
- SIS: specified by the robot's SIS (Service Information System). A typical value is given for a typical work cycle, but the value will differ depending on how hard each part is run.

The SIS used in M2004 is further described in the *Operating manual - Service Information System*.

Robots with the functionality *Service Information System* activated can show active counters in the device browser in RobotStudio, or on the FlexPendant.

## 3 Maintenance

### 3.3.2 Maintenance schedule

### 3.3.2 Maintenance schedule

#### Scheduled and non-predictable maintenance

The robot must be maintained regularly to ensure proper function. The maintenance activities and intervals are specified in the table below.

Non-predictable situations also give rise to inspections of the robot. Any damages must be attended to immediately!

#### Life of each component

The inspection intervals *do not* specify the life of each component.

#### Activities and intervals, standard equipment

The table below specifies the required maintenance activities and intervals:

Maintenance activities	Regularly <sup>i</sup>	Every 100 km	Every 12 months	Every 20,000 hours <sup>ii</sup>	Reference
<b>Cleaning activities</b>					
Cleaning the robot	x				<a href="#">Cleaning the IRB 910SC on page 116</a>
<b>Inspection activities</b>					
Inspecting the robot	x				Check for abnormal wear or contamination.
Inspecting the robot cabling <sup>iii</sup>	x <sup>iv</sup>				<a href="#">Inspecting the cabling on page 84</a>
Inspecting the information labels			x		<a href="#">Inspecting the information labels on page 85</a>
Inspecting the ball screw spline unit	x <sup>v</sup>				<a href="#">Inspecting the ball screw spline unit on page 88</a>
Inspecting the axis-1 and axis-2 mechanical stops	x <sup>vi</sup>				<a href="#">Inspecting axis-1 and axis-2 mechanical stops on page 91</a>
Inspecting the timing belts			x		<a href="#">Inspecting the timing belts on page 94</a>
<b>Replacement/changing activities</b>					
Replacing the battery pack <sup>vii</sup>					<a href="#">Replacing the battery pack on page 102</a>
<b>Lubrication activities</b>					
Lubricating the ball screw spline unit		x			<a href="#">Lubricating the ball screw spline unit on page 113</a>
<b>Overhaul</b>					

*Continues on next page*

Maintenance activities	Regularly <sup>i</sup>	Every 100 km	Every 12 months	Every 20,000 hours <sup>ii</sup>	Reference
Overhaul of complete robot				x	

- i "Regularly" implies that the activity is to be performed regularly, but the actual interval may not be specified by the robot manufacturer. The interval depends on the operation cycle of the robot, its working environment and movement pattern. Generally, the more contaminated environment, the shorter intervals. The more demanding movement pattern (sharper bending cable harness), the shorter intervals.
- ii Operating hours counted by the DTC = Duty time counter.
- iii The robot cabling comprises the cabling between the robot and controller cabinet.
- iv Replace when damage or cracks is detected or life limit is approaching.
- v Inspect immediately if the stop blocks are hit.
- vi Inspect immediately if the mechanical stop is hit.
- vii The battery low alert (38213 **Battery charge low**) is displayed when remaining backup capacity (robot powered off) is less than 2 months. Typical life of a new battery is 36 months if the robot is powered off 2 days/week, or 18 months if the robot is powered off 16 hours/day. The life can be extended (approximately 3 times) for longer production breaks by a battery shutdown service routine. See *Operating manual - IRC5 with FlexPendant*.  
See the replacement instruction for more details.

## 3 Maintenance

---

### 3.4.1 Inspecting the cabling

## 3.4 Inspection activities

### 3.4.1 Inspecting the cabling

---

#### Location of robot cabling

The robot cabling comprises the cabling between the robot and controller cabinet as well as the externally visible cabling from the base to the upper arm.

---

#### Required tools and equipment

Visual inspection, no tools are required.

Other tools and procedures may be required if the spare part needs to be replaced. These are specified in the replacement procedure.

---

#### Inspection, robot cabling

Use this procedure to inspect the robot cabling.

	Action	Note
1	 <b>DANGER</b> Turn off all: <ul style="list-style-type: none"><li>• electric power supply to the robot</li><li>• hydraulic pressure supply to the robot</li><li>• air pressure supply to the robot</li></ul> Before entering the robot working area.	
2	Visually inspect: <ul style="list-style-type: none"><li>• the control cabling between the robot and control cabinet</li><li>• the externally visible cabling from the base to the upper arm</li></ul> Look for abrasions, cuts or crush damages.	
3	Replace the cabling if wear or damage is detected.	See <a href="#">Replacing the main cable package on page 125</a> .



### 3.4.2 Inspecting the information labels

#### Location of labels

This figure shows the location of the information labels to be inspected. The symbols are described in section [Safety symbols on manipulator labels on page 21](#).

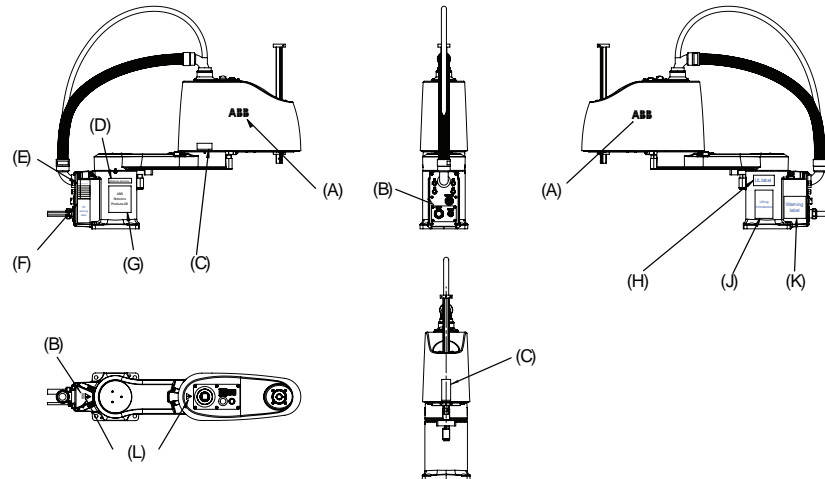

xx1500002258

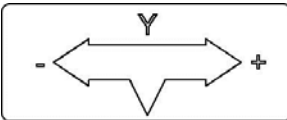
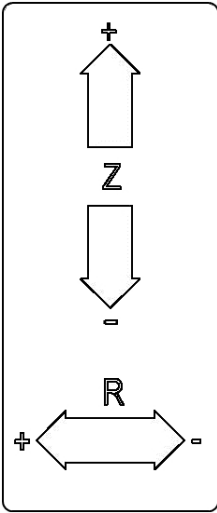

Pos	Description	Illustration
A	ABB logo, large size	
B	ABB logo, small size	
C	Synchronization mark for axis 2	 xx1500002671
	Synchronization mark for axis 3 and 4	 xx1500002672
D	AbsAcc label	
E	Calibration label	

Continues on next page

### 3 Maintenance

#### 3.4.2 Inspecting the information labels

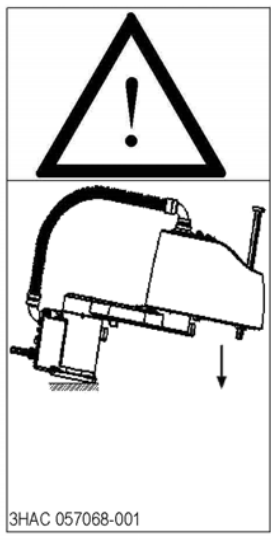
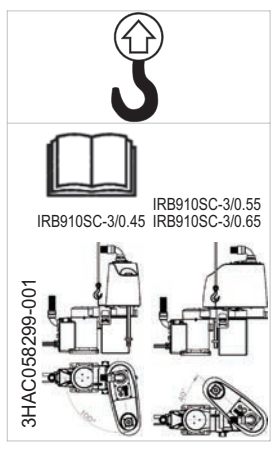
Continued

<p>F</p>	<p>Warning label Tip risk when loosening bolts</p>	 <p>3HAC 057068-001</p> <p>xx1500002402</p>
<p>G</p>	<p>Rating label</p>	
<p>H</p>	<p>UL label</p>	
<p>J</p>	<p>Instruction label Lifting of robot</p>	 <p>IRB910SC-3/0.55 IRB910SC-3/0.65</p> <p>3HAC058299-001</p> <p>xx1600000282</p>
<p>K</p>	<p>Instruction label Brake release Moving robot Brake release buttons</p>	 <p>3HAC057070-001</p> <p>xx1500002403</p>
<p>L</p>	<p>Warning label Flash</p>	 <p>xx1300001091</p>

Continues on next page

#### Required spare parts



#### Note

The spare part numbers that are listed in the table can be out of date. See the latest spare parts of the IRB 910SC via myABB Business Portal, [www.abb.com/myABB](http://www.abb.com/myABB).

Spare part	Article number	Note
ABB logo, small size	3HAC0453-6	
ABB logo, large size	3HAC0453-2	
Warning label	3HAC057068-001	Risk of tipping
Warning sign	3HAC1589-1	Electrical shock
Rating label	3HAB9549-1	
UL label	3HAC037252-001	
Lifting label	3HAC058299-001	
Instruction label	3HAC057070-001	Break release, moving robot
Calibration label	3HAC13488-1	
Calibration mark (axis 2)	3HAC057089-001	
Calibration mark (axis 3 and axis 4)	3HAC057090-001	

#### Required tools and equipment

Visual inspection, no tools are required.

#### Inspecting, labels

	Action	Note
1	 <b>DANGER</b> Turn off all: <ul style="list-style-type: none"> <li>• electric power supply</li> <li>• hydraulic pressure supply</li> <li>• air pressure supply</li> </ul> to the robot, before entering the robot working area.	
2	Inspect the labels, located as shown in the figures.	See the figures in <a href="#">Location of labels on page 85</a> .
3	Replace any missing or damaged labels.	

### 3 Maintenance

#### 3.4.3 Inspecting the ball screw spline unit

#### 3.4.3 Inspecting the ball screw spline unit

##### Location of ball screw spline unit

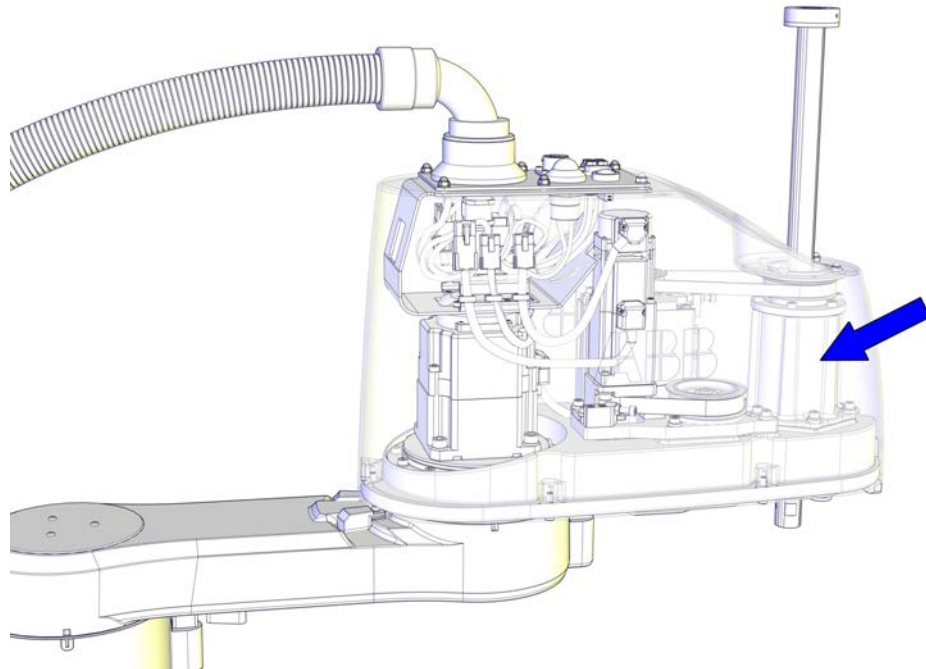

xx1500002212

##### Required spare parts



##### Note

The spare part numbers that are listed in the table can be out of date. See the latest spare parts of the IRB 910SC via myABB Business Portal, [www.abb.com/myABB](http://www.abb.com/myABB).

Spare part	Article number	Note
Ball screw spline unit	3HAC056148-001	

##### Required tools and equipment

Equipment	Note
24 VDC power supply	Used to release the motor brakes.
Other tools and procedures may be required if the spare part needs to be replaced. These are specified in the replacement procedure.	

*Continues on next page*

#### Inspecting, ball screw spline unit

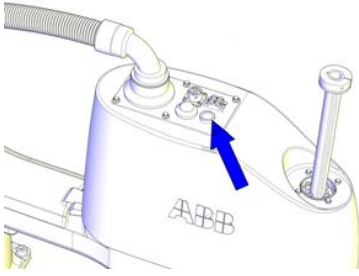
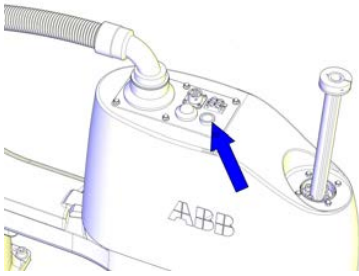
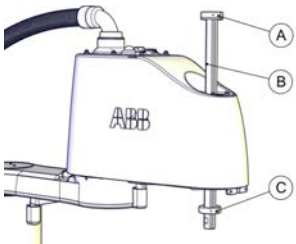
	Action	Note						
1	Turn on the electric power to the robot. If the robot is not connected to the controller, power must be supplied to the connector R1.MP according to the section <a href="#">Supplying power to connector R1.MP on page 63</a> .							
2	 <b>DANGER</b>  When releasing the holding brakes, the robot axes may move very quickly and sometimes in unexpected ways!  Make sure the payload is disassembled or tooling is properly supported; otherwise, fast downward movements of axis 3 may cause severe hits.							
3	Release the holding brake by pressing the button on the internal brake release unit.	 <small>xx1500002774</small>						
4	Move the upper arm to a position where the axis 3 can be moved in full stroke.							
5	Press the brake release button and move the shaft to its upper and lower limits manually.	 <small>xx1500002774</small>						
6	Visually inspect: <ul style="list-style-type: none"> <li>• the stop blocks on the ball screw spline unit</li> <li>• the shaft of the ball screw spline unit</li> </ul> Look for abrasions, cuts or crush damages on the spline, and grease amount on the shaft.	 <small>xx1500002778</small> <table border="1" data-bbox="1066 1865 1434 2002"> <tbody> <tr> <td>A</td> <td>Upper stop block</td> </tr> <tr> <td>B</td> <td>Shaft</td> </tr> <tr> <td>C</td> <td>Lower stop block</td> </tr> </tbody> </table>	A	Upper stop block	B	Shaft	C	Lower stop block
A	Upper stop block							
B	Shaft							
C	Lower stop block							

Continues on next page

### 3 Maintenance

#### 3.4.3 Inspecting the ball screw spline unit

*Continued*

	Action	Note
7	Apply grease to the shaft if it is not enough.	See <a href="#">Lubricating the ball screw spline unit on page 113</a> .  xx1500002779
8	Replace the ball screw spline unit if wear or damage is detected.	See <a href="#">Replacing the ball screw spline unit on page 232</a> .

3.4.4 Inspecting axis-1 and axis-2 mechanical stops

Location of axis-1 and axis-2 mechanical stops

The mechanical stops on axes 1 and 2 are located as shown in the figures.

Axis 1

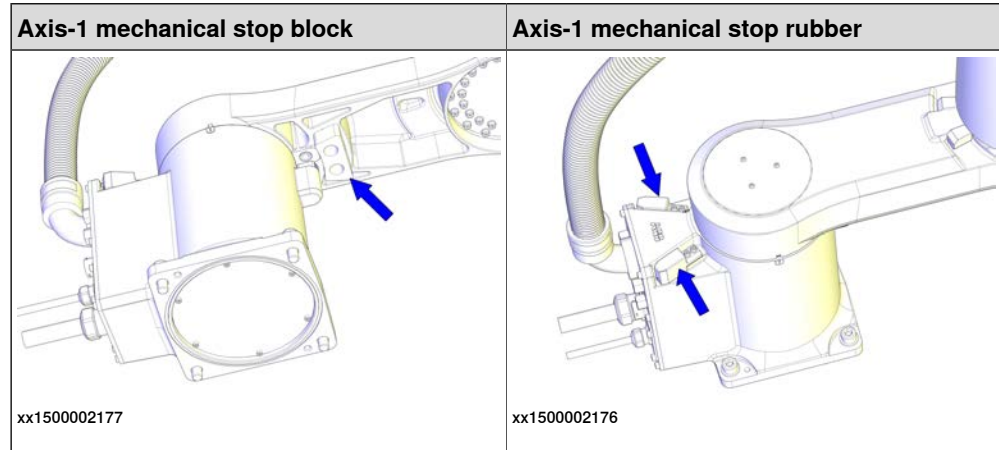

Axis 2

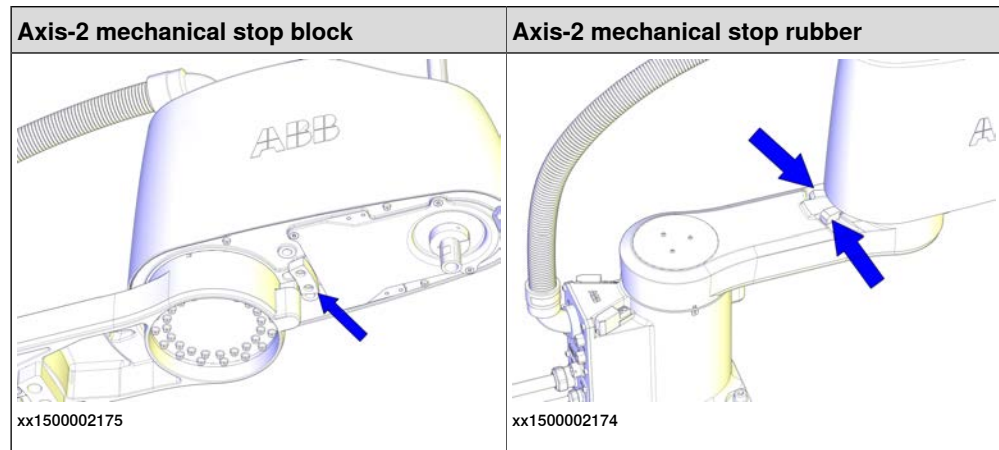

Required spare parts



Note

The spare part numbers that are listed in the table can be out of date. See the latest spare parts of the IRB 910SC via myABB Business Portal, [www.abb.com/myABB](http://www.abb.com/myABB).

Spare part	Article number	Note
Axis-1 mechanical stop rubber	3HAC056042-001	Replace if damaged.
Axis-1 mechanical stop block	3HAC055164-001	Replace if damaged.
Axis-2 mechanical stop rubber	3HAC056017-001	Replace if damaged.
Axis-2 mechanical stop block	3HAC055185-001	Replace if damaged.

Continues on next page

### 3 Maintenance

#### 3.4.4 Inspecting axis-1 and axis-2 mechanical stops

*Continued*

#### Required tools and equipment

Visual inspection, no tools are required.

Other tools and procedures may be required if the spare part needs to be replaced. These are specified in the replacement procedure.

#### Inspecting, axis-1 and axis-2 mechanical stops

Use this procedure to inspect mechanical stops on axes 1 and 2.

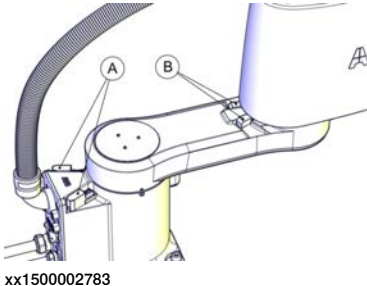
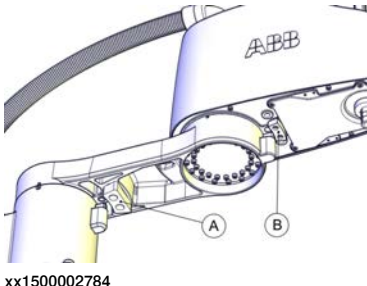
	Action	Information								
1	 <b>DANGER</b> Turn off all: <ul style="list-style-type: none"> <li>• electric power supply</li> <li>• hydraulic pressure supply</li> <li>• air pressure supply</li> </ul> to the robot, before entering the robot working area.									
2	Inspect the mechanical stops.	 <p>xx1500002783</p> <table border="1" data-bbox="1038 1182 1406 1328"> <tr> <td>A</td> <td>Axis-1 mechanical stop rubbers</td> </tr> <tr> <td>B</td> <td>Axis-2 mechanical stop rubbers</td> </tr> </table>  <p>xx1500002784</p> <table border="1" data-bbox="1038 1646 1406 1736"> <tr> <td>A</td> <td>Axis-1 mechanical stop block</td> </tr> <tr> <td>B</td> <td>Axis-2 mechanical stop block</td> </tr> </table>	A	Axis-1 mechanical stop rubbers	B	Axis-2 mechanical stop rubbers	A	Axis-1 mechanical stop block	B	Axis-2 mechanical stop block
A	Axis-1 mechanical stop rubbers									
B	Axis-2 mechanical stop rubbers									
A	Axis-1 mechanical stop block									
B	Axis-2 mechanical stop block									

*Continues on next page*



	Action	Information
3	<p>Replace if any mechanical stop is:</p> <ul style="list-style-type: none"><li>• bent</li><li>• loose</li><li>• damaged.</li></ul> <p> <b>Note</b></p> <p>The expected life of gearboxes can be reduced as a result of collisions with the mechanical stop.</p>	

## 3 Maintenance

### 3.4.5 Inspecting the timing belts

### 3.4.5 Inspecting the timing belts

#### Location of timing belts

The timing belts are located as shown in the figures.

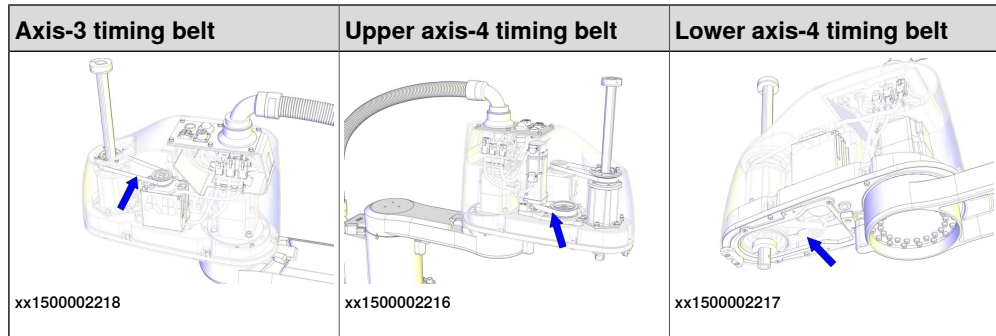

#### Required tools and equipment

Equipment	Note
Standard toolkit	The content is defined in the section <a href="#">Standard toolkit on page 392</a> .
Sonic tensiometer	Used for measuring the timing belt tension.
Other tools and procedures may be required if the spare part needs to be replaced. These are specified in the replacement procedure.	

#### Timing belt tension

The table describes the timing belt tension.

Axis	Timing belt tension
Axis 3	Recommended: 34 N Tension range of new belt: 31.1 to 34.2 N Tension range of used belt <sup>i</sup> : 21.8 N to 24.9 N
Axis 4	<b>Upper timing belt</b> Recommended: 37 N Tension range of new belt: 34.5 N to 37.9 N Tension range of used belt <sup>i</sup> : 24.1 N to 27.6 N
	<b>Lower timing belt</b> Recommended: 101 N Tension range of new belt: 92.2 N to 101 N Tension range of used belt <sup>i</sup> : 64.5 N to 73.7 N



<sup>i</sup> Used belt is the one having been installed and used for more than 24 hours.

*Continues on next page*

#### Inspecting timing belts

Use this procedure to inspect timing belts.

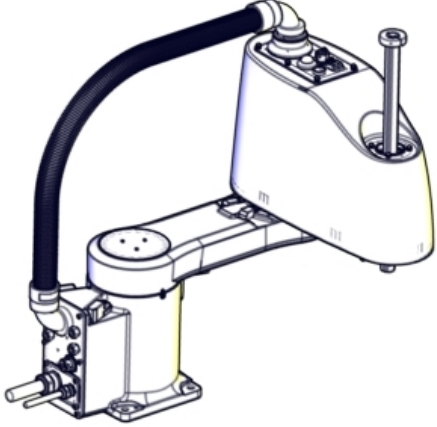
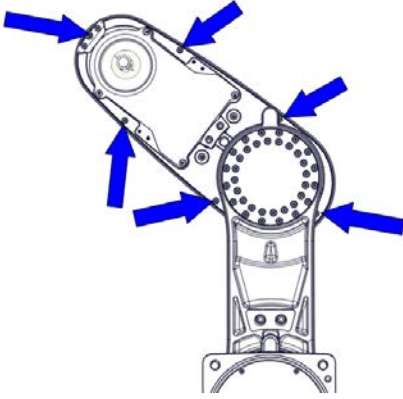
#### Preparations before inspecting timing belts

	Action	Note
1	Jog axis 2 to access the cover screws.	 <p data-bbox="970 952 1077 969">xx1500002520</p>  <p data-bbox="970 1402 1077 1420">xx1500002782</p>
2	<p data-bbox="502 1473 571 1541"> <b>DANGER</b></p> <p data-bbox="496 1547 628 1574">Turn off all:</p> <ul data-bbox="531 1583 858 1677" style="list-style-type: none"> <li data-bbox="531 1583 807 1612">• electric power supply</li> <li data-bbox="531 1615 858 1644">• hydraulic pressure supply</li> <li data-bbox="531 1646 783 1675">• air pressure supply</li> </ul> <p data-bbox="496 1682 916 1738">to the robot, before entering the robot working area.</p>	



*Continues on next page*

### 3 Maintenance

#### 3.4.5 Inspecting the timing belts

*Continued*

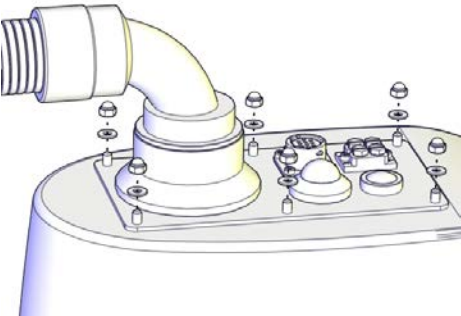

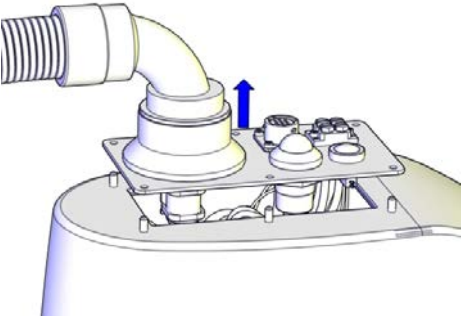
#### Removing the main cable package from the upper arm

	Action	Note
1	 <b>DANGER</b> Make sure that all supplies for electrical power, hydraulic pressure, and air pressure are turned off.	
2	Remove the dome nuts and washers.	 xx1500002182
3	 <b>CAUTION</b> The plate cannot be removed completely until the connectors are disconnected, as shown in the following step.	 xx1500002183

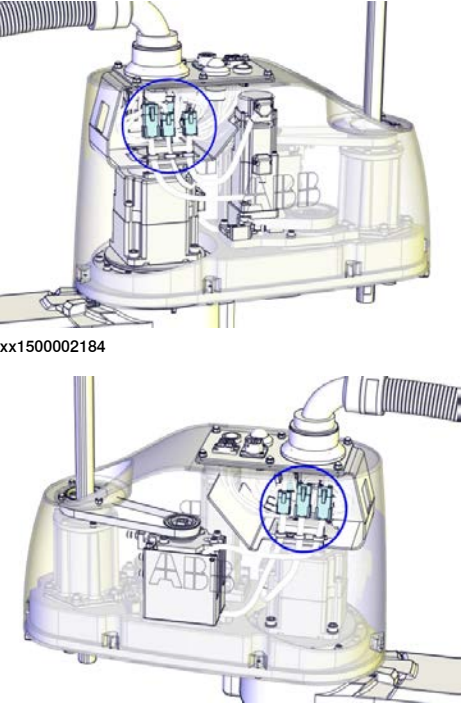
*Continues on next page*

	Action	Note
4	<p>Disconnect the connectors:</p> <ul style="list-style-type: none"> <li>• R2.MP2</li> <li>• R2.MP3</li> <li>• R2.MP4</li> <li>• R2.ME2</li> <li>• R2.ME3</li> <li>• R2.ME4</li> </ul> <p> <b>Tip</b></p> <p>Take photos of the connectors and cable position before disconnecting them, to have as a reference when reconnecting.</p>	 <p>xx1500002184</p> <p>xx1500002185</p>

#### Removing the upper cover

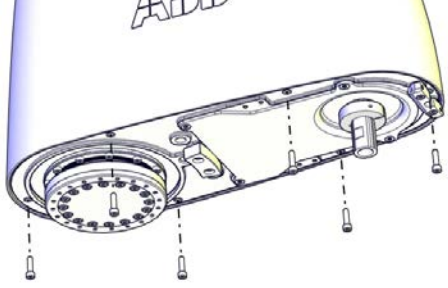
	Action	Note
1	<p> <b>DANGER</b></p> <p>Make sure that all supplies for electrical power, hydraulic pressure, and air pressure are turned off.</p>	
2	<p> <b>WARNING</b></p> <p>Risk of tipping. Make sure the robot is well secured and that the upper arm is supported during the removal work.</p>	
3	<p>Remove the screws.</p>	 <p>xx1500002220</p>

*Continues on next page*



### 3 Maintenance

#### 3.4.5 Inspecting the timing belts

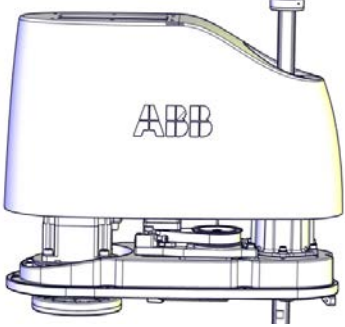
Continued

	Action	Note
4	 <b>WARNING</b> The cover may be damaged due to improper shift. Keep the cover in position while removing the screws.	
5	Lift out the upper cover carefully.	 <p>xx1500002221</p>

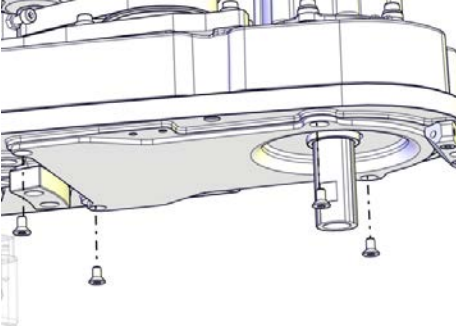
#### Removing the lower cover

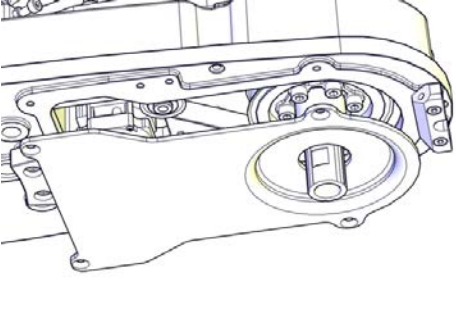
	Action	Note
1	 <b>DANGER</b> Make sure that all supplies for electrical power, hydraulic pressure, and air pressure are turned off.	
2	Remove the screws.	 <p>xx1500002785</p>
3	Remove the cover.   <b>Tip</b> If only working with lower axis-4 timing belt, no need to remove the stop block of ball screw spline unit before removing the lower cover.	 <p>xx1500002225</p>

Continues on next page

#### Inspecting timing belts

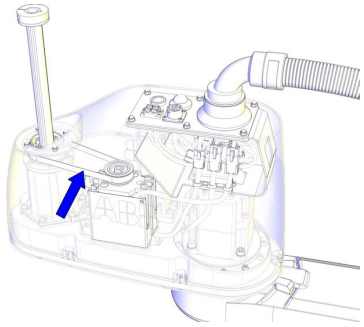
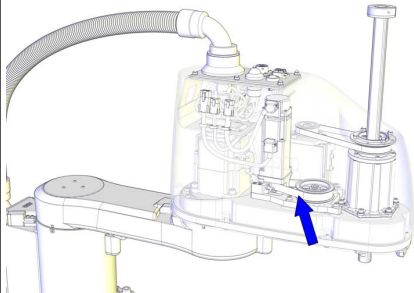
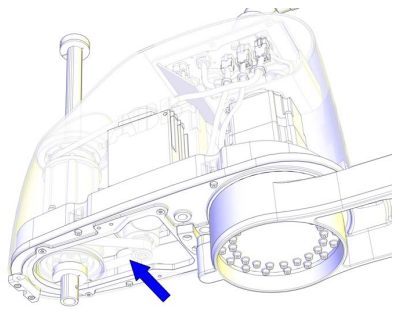
	Action	Information
1	Check the timing belts for damage or wear.	 <p>xx150002218</p>  <p>xx150002216</p>  <p>xx150002217</p>

*Continues on next page*

### 3 Maintenance

#### 3.4.5 Inspecting the timing belts

*Continued*

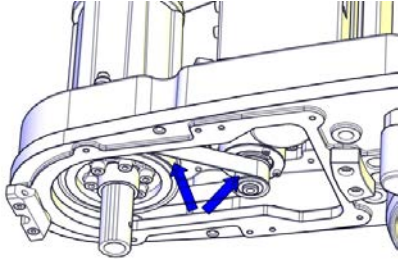
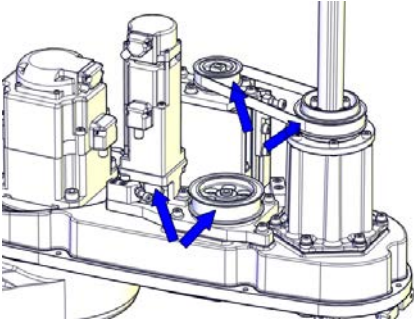
	Action	Information
2	Check the timing belt pulleys for damage.	 <p data-bbox="954 633 1062 656">xx1500002780</p>  <p data-bbox="954 1003 1062 1025">xx1500002781</p>
3	If any damage or wear is detected, the part must be replaced!	
4	Check each belt for tension.	Timing belt tensions are specified in <i>Timing belt tension on page 94</i> .

*Continues on next page*

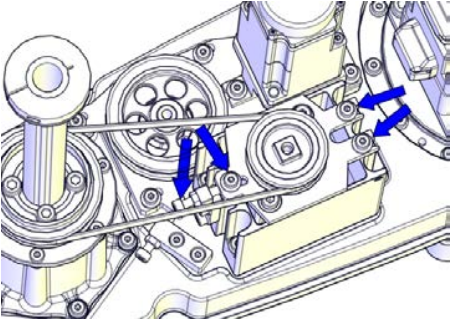
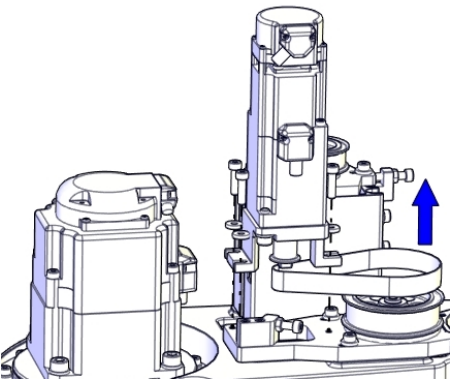
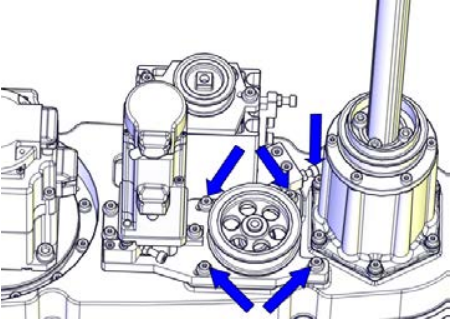

	Action	Information
5	<p>If the belt tension is not correct, adjust screws while using a sonic tensiometer to measure the belt tension until a proper belt tension is achieved!</p>	 <p>xx1500002229</p>  <p>xx1500002233</p>  <p>xx1500002231</p>

## 3 Maintenance

### 3.5.1 Replacing the battery pack

## 3.5 Replacement/changing activities

### 3.5.1 Replacing the battery pack



#### Note

The battery low alert (38213 **Battery charge low**) is displayed when remaining backup capacity (robot powered off) is less than 2 months. Typical life of a new battery is 36 months if the robot is powered off 2 days/week, or 18 months if the robot is powered off 16 hours/day. The life can be extended (approximately 3 times) for longer production breaks by a battery shutdown service routine. See *Operating manual - IRC5 with FlexPendant*.

#### Location of the battery pack

The battery pack is located as shown in the figure.

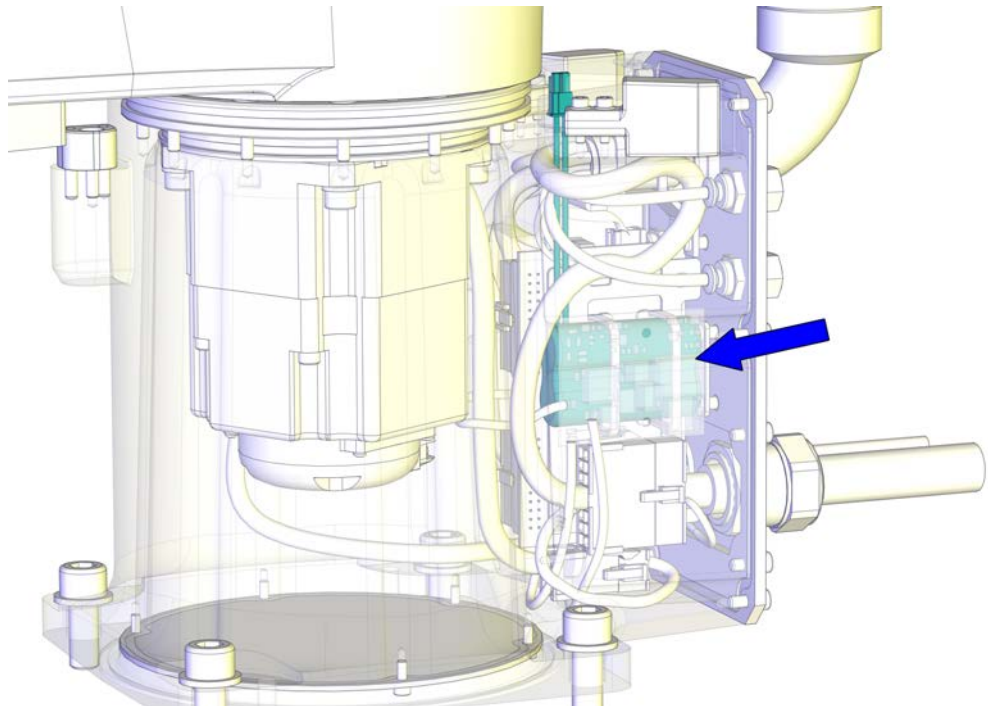

xx1500002180

#### Required spare parts



#### Note

The spare part numbers that are listed in the table can be out of date. See the latest spare parts of the IRB 910SC via myABB Business Portal, [www.abb.com/myABB](http://www.abb.com/myABB).

*Continues on next page*

*Continued*

Spare part	Article number	Note
Battery pack	3HAC051036-001	Battery includes protection circuits. Only replace with a specified spare part or an ABB-approved equivalent.

#### Required tools and equipment

Equipment	Article number	Note
Standard toolkit	-	Content is defined in section <a href="#">Standard toolkit on page 392</a> .



#### Required consumables

Consumable	Article number	Note
Cable ties	-	

#### Removing the battery pack

Use these procedures to remove the battery pack.

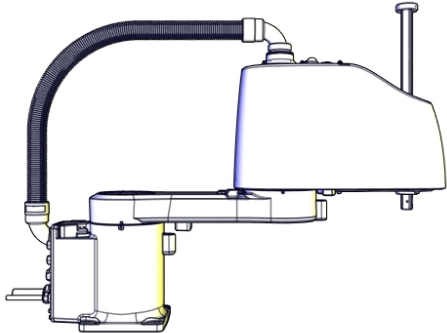
#### Preparations before removing the battery pack

	Action	Note
1	Jog all axes to zero position.	 <p>xx1500002227</p>
2	 <p><b>DANGER</b></p> <p>Turn off all:</p> <ul style="list-style-type: none"> <li>• electric power supply</li> <li>• hydraulic pressure supply</li> <li>• air pressure supply</li> </ul> <p>to the robot, before entering the robot working area.</p>	





*Continues on next page*

### 3 Maintenance

#### 3.5.1 Replacing the battery pack

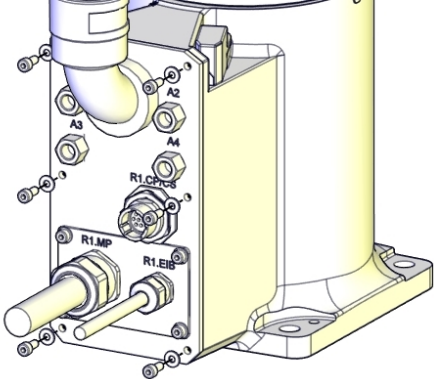

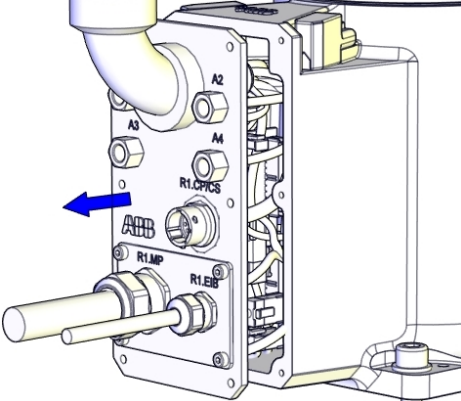
*Continued*

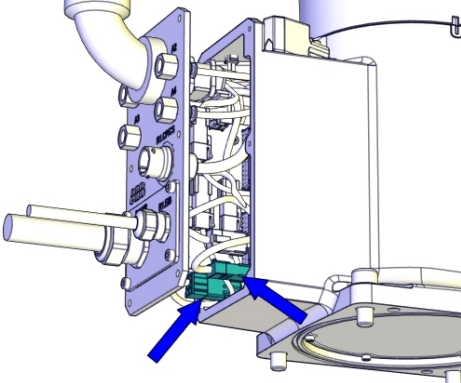
#### Removing the main cable package from the base

	Action	Note
1	 <p><b>DANGER</b></p> <p>Make sure that all supplies for electrical power, hydraulic pressure, and air pressure are turned off.</p>	
2	Remove the screws and washers.	 <p>xx1500002186</p>
3	<p>Carefully open the base cover and pull out the cable package.</p> <p> <b>CAUTION</b></p> <p>The cover cannot be removed completely until the connectors are disconnected.</p> <p> <b>CAUTION</b></p> <p>Clean cover from metal residues before opening.</p> <p>Metal residues can cause shortage on the boards which can result in hazardous failures.</p>	 <p>xx1500002187</p>
4	<p>Disconnect the connectors:</p> <ul style="list-style-type: none"> <li>• R2.MP1</li> <li>• R2.ME1</li> </ul> <p> <b>Tip</b></p> <p>Take photos of the connectors and cable position before disconnecting them, to have as a reference when reconnecting.</p>	 <p>xx1500002188</p>

*Continues on next page*

#### Removing the PCB board

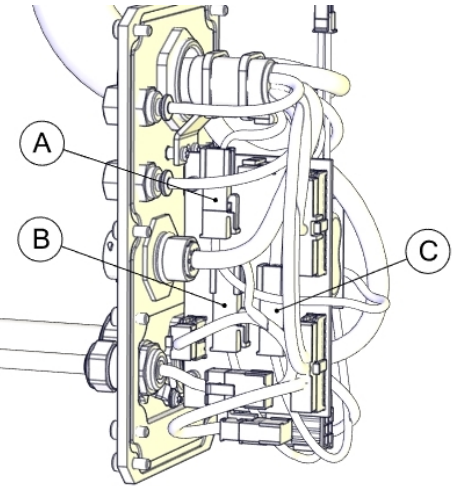
	Action	Note						
1	 <p><b>DANGER</b></p> <p>Make sure that all supplies for electrical power, hydraulic pressure, and air pressure are turned off.</p>							
2	 <p><b>ELECTROSTATIC DISCHARGE (ESD)</b></p> <p>The unit is sensitive to ESD. Before handling the unit please read the safety information in the section <a href="#">The unit is sensitive to ESD on page 53</a></p>							
3	<p>Disconnect the connectors:</p> <ul style="list-style-type: none"> <li>• R1.BK1-2</li> <li>• R1.DBP</li> <li>• R2.BK1-2</li> </ul> <p> <b>Tip</b></p> <p>Take photos of the connectors and cable position before disconnecting them, to have as a reference when reconnecting.</p>	 <p>xx1500002190</p> <table border="1" data-bbox="973 1339 1439 1473"> <tbody> <tr> <td>A</td> <td>R1.BK1-2</td> </tr> <tr> <td>B</td> <td>R1.DBP</td> </tr> <tr> <td>C</td> <td>R2.BK1-2</td> </tr> </tbody> </table>	A	R1.BK1-2	B	R1.DBP	C	R2.BK1-2
A	R1.BK1-2							
B	R1.DBP							
C	R2.BK1-2							



### 3 Maintenance

#### 3.5.1 Replacing the battery pack

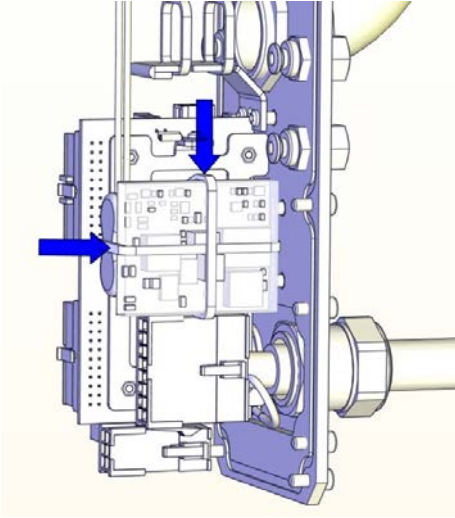
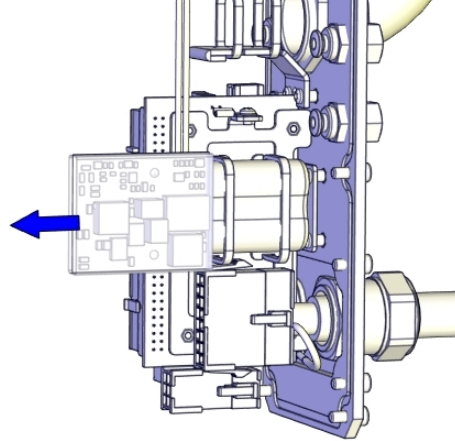
Continued

	Action	Note
4	Cut the cable ties.	 <p data-bbox="943 831 1050 853">xx1500002752</p>
5	Remove the PCB board carefully.	 <p data-bbox="943 1346 1050 1368">xx1500002191</p>

#### Disconnecting the battery cable



	Action	Note
1	 <p data-bbox="555 1547 667 1576"><b>DANGER</b></p> <p data-bbox="464 1608 933 1688">Make sure that all supplies for electrical power, hydraulic pressure, and air pressure are turned off.</p>	
2	 <p data-bbox="555 1749 916 1805"><b>ELECTROSTATIC DISCHARGE (ESD)</b></p> <p data-bbox="464 1823 933 1926">The unit is sensitive to ESD. Before handling the unit please read the safety information in the section <a href="#">The unit is sensitive to ESD on page 53</a></p>	

Continues on next page

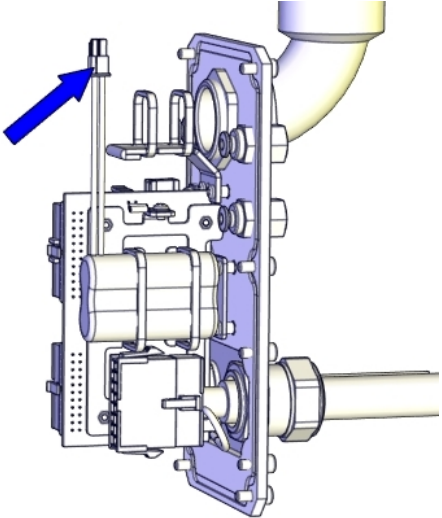
*Continued*

	Action	Note
3	Disconnect the battery cable.	 <p data-bbox="970 840 1082 857">xx1500002192</p>

#### Removing the battery pack

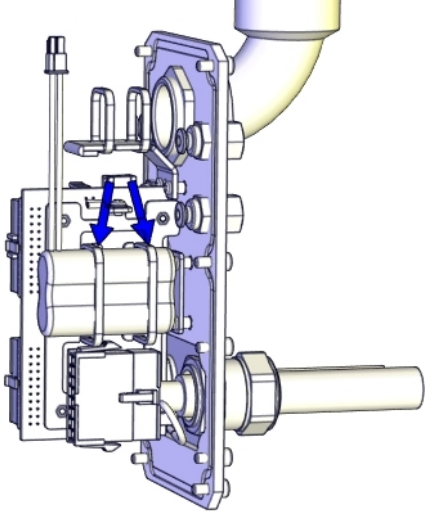
	Action	Note
1	 <p data-bbox="587 1041 694 1070"><b>DANGER</b></p> <p data-bbox="497 1102 962 1182">Make sure that all supplies for electrical power, hydraulic pressure, and air pressure are turned off.</p>	
2	 <p data-bbox="587 1238 946 1294"><b>ELECTROSTATIC DISCHARGE (ESD)</b></p> <p data-bbox="497 1312 962 1420">The unit is sensitive to ESD. Before handling the unit please read the safety information in the section <a href="#">The unit is sensitive to ESD on page 53</a></p>	
3	Cut the cable ties.	 <p data-bbox="970 1982 1082 2000">xx1500002193</p>

*Continues on next page*

### 3 Maintenance

#### 3.5.1 Replacing the battery pack

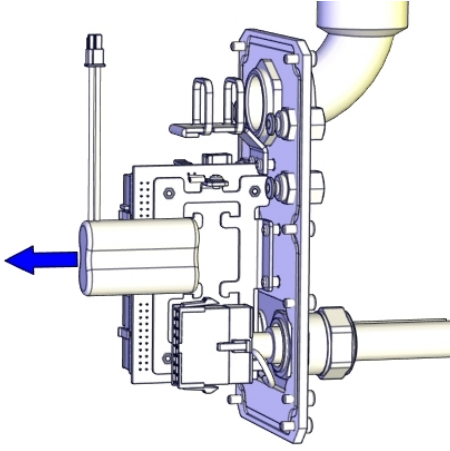

Continued

	Action	Note
4	<p>Remove the battery.</p> <p> <b>Note</b></p> <p>Battery includes protection circuits. Only replace with a specified spare part or with an ABB- approved equivalent.</p>	 <p>xx1500002194</p>

#### Refitting the battery pack

Use these procedures to refit the battery pack.

#### Refitting the battery pack

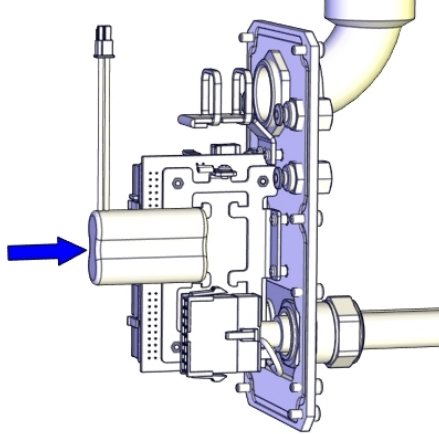
	Action	Note
1	<p> <b>ELECTROSTATIC DISCHARGE (ESD)</b></p> <p>The unit is sensitive to ESD. Before handling the unit please read the safety information in the section <a href="#">The unit is sensitive to ESD on page 53</a></p>	
2	<p>Fit the battery.</p> <p> <b>Note</b></p> <p>Battery includes protection circuits. Only replace with a specified spare part or with an ABB- approved equivalent.</p>	 <p>xx1500002206</p>

Continues on next page

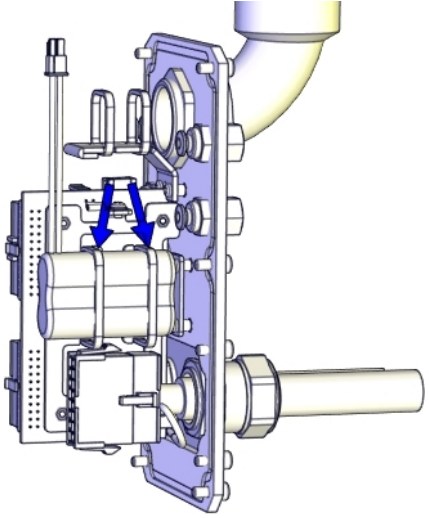

	Action	Note
3	Secure the battery with cable ties.	 <p data-bbox="970 840 1082 862">xx1500002193</p>

#### Connecting the battery cable

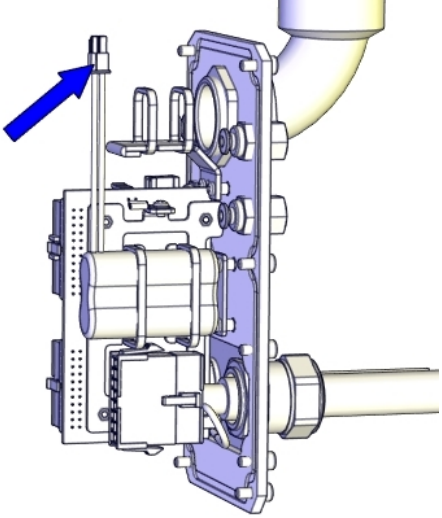
	Action	Note
1	 <p data-bbox="587 1032 946 1088"><b>ELECTROSTATIC DISCHARGE (ESD)</b></p> <p data-bbox="497 1111 962 1216">The unit is sensitive to ESD. Before handling the unit please read the safety information in the section <i>The unit is sensitive to ESD on page 53</i></p>	
2	Connect the battery cable.	 <p data-bbox="970 1780 1082 1803">xx1500002192</p>



*Continues on next page*

## 3 Maintenance

### 3.5.1 Replacing the battery pack

*Continued*

#### Refitting the PCB board

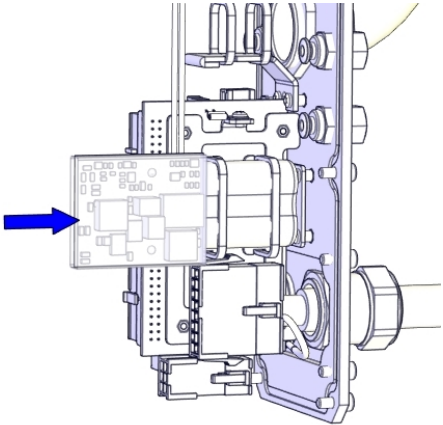
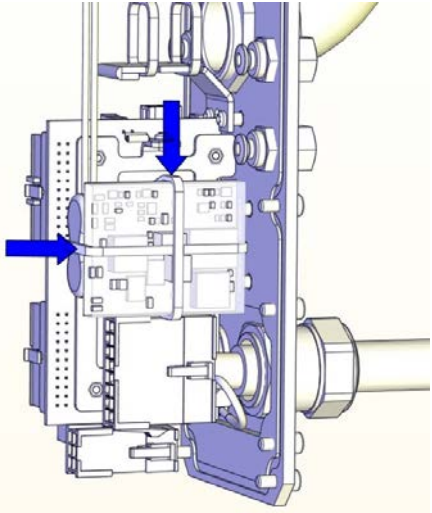
	Action	Note
1	 <b>ELECTROSTATIC DISCHARGE (ESD)</b>  The unit is sensitive to ESD. Before handling the unit please read the safety information in the section <i>The unit is sensitive to ESD on page 53</i>	
2	Refit the PCB board.   <b>Note</b>  The PCB board is protected by shrink hose. Replace the hose if damaged.	<b>PCB board: 3HAC057687-001</b>   xx150002205
3	Secure the PCB board with cable ties. Do not tighten the ties too tight.	  xx150002752

*Continues on next page*

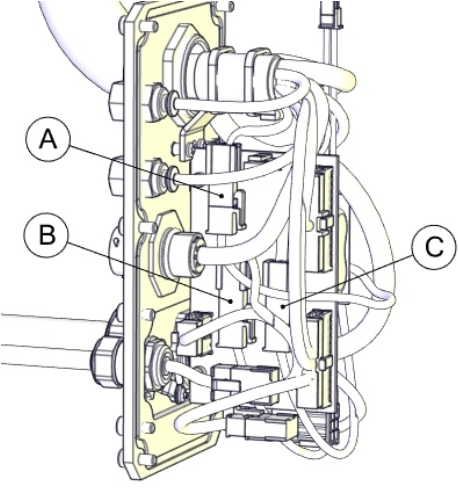
	Action	Note						
4	<p>Reconnect the connectors.</p> <ul style="list-style-type: none"> <li>• R1.BK1-2</li> <li>• R1.DBP</li> <li>• R2.BK1-2</li> </ul> <p> <b>CAUTION</b></p> <p>Make sure not to mix the connectors. See the labels on the connectors for correct connection.</p>	 <p>xx1500002190</p> <table border="1" data-bbox="973 840 1436 974"> <tr> <td>A</td> <td>R1.BK1-2</td> </tr> <tr> <td>B</td> <td>R1.DBP</td> </tr> <tr> <td>C</td> <td>R2.BK1-2</td> </tr> </table>	A	R1.BK1-2	B	R1.DBP	C	R2.BK1-2
A	R1.BK1-2							
B	R1.DBP							
C	R2.BK1-2							
5	Secure the cables with cable ties if needed.							

#### Refitting the main cable to the base

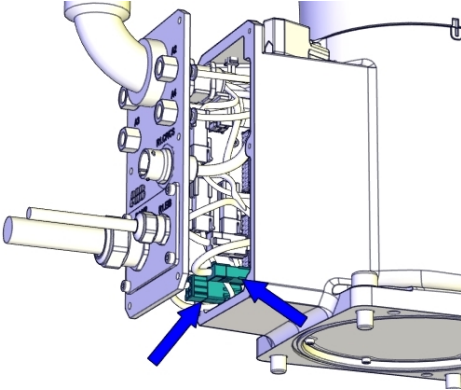
	Action	Note
1	Secure the main cable package with cable ties if needed.	
2	<p>Reconnect the connectors.</p> <ul style="list-style-type: none"> <li>• R2.MP1</li> <li>• R2.ME1</li> </ul>	 <p>xx1500002188</p>

*Continues on next page*

### 3 Maintenance

#### 3.5.1 Replacing the battery pack

Continued

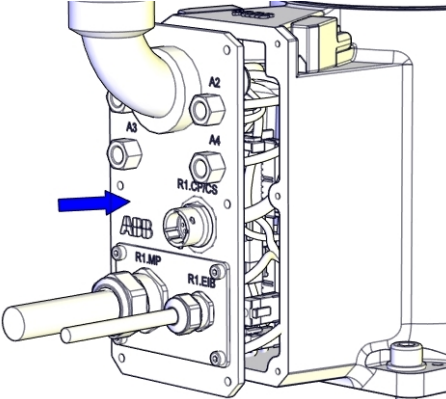
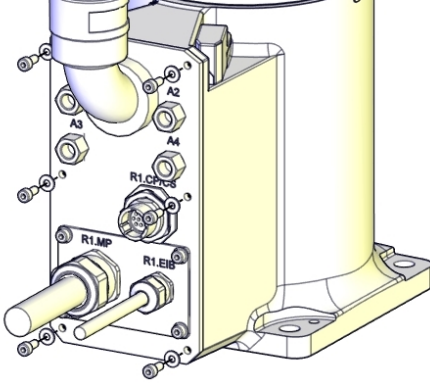
	Action	Note
3	Push the main cable package into place.	 <p>xx1500002204</p>
4	Refit the base cover with screws and washers.	 <p>xx1500002186</p> <p>Screws: M4x10 (6 pcs) Tightening torque: 2 Nm</p>

#### Concluding procedure

	Action	Note
1	Update the revolution counters.	See <a href="#">Updating revolution counters on page 355</a> .
2	 <p><b>DANGER</b></p> <p>Make sure all safety requirements are met when performing the first test run. These are further detailed in the section "First test run may cause injury or damage" in <i>Safety manual for robot - Manipulator and IRC5 or OmniCore controller</i>.</p>	

### 3.6 Lubrication activities

#### 3.6.1 Lubricating the ball screw spline unit

##### Location of the ball screw spline unit

The ball screw spline unit is located as shown in the figure.

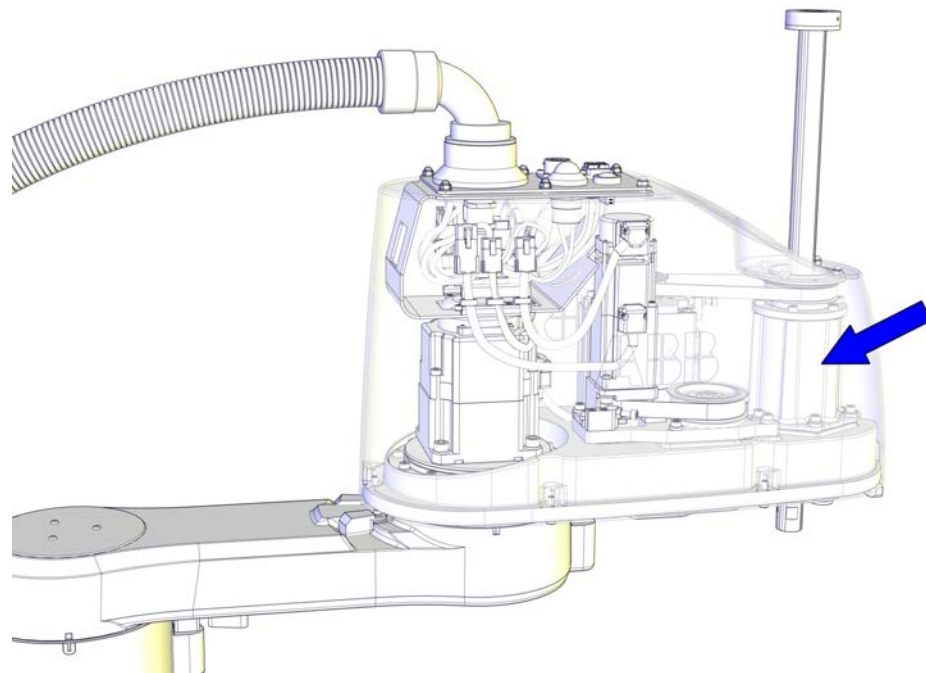

xx1500002212

##### Required tools and equipment

Equipment	Article number	Note
24 VDC power supply	-	Used to release the motor brakes.

##### Required consumables

Consumable	Article number	Note
Grease	-	THK AFA Used for lubricating the ball screw spline shaft.

##### Lubricating the ball screw spline unit



##### Note

Cover the end effector and peripheral equipment in case the grease drips, before lubricating the ball screw spline unit.

*Continues on next page*

### 3 Maintenance

#### 3.6.1 Lubricating the ball screw spline unit

Continued

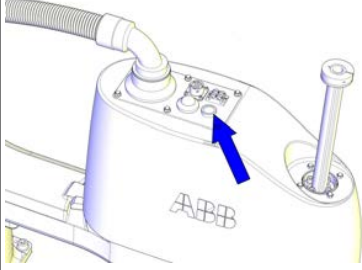
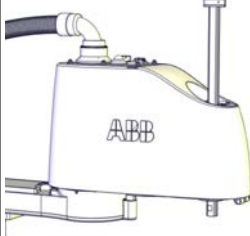
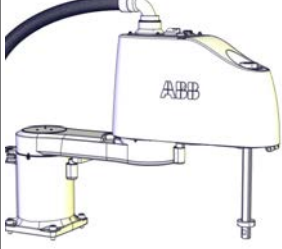
	Action	Note
1	Turn on the electric power to the robot. If the robot is not connected to the controller, power must be supplied to the connector R1.MP according to the section <a href="#">Supplying power to connector R1.MP on page 63</a> .	
2	 <b>DANGER</b> When releasing the holding brakes, the robot axes may move very quickly and sometimes in unexpected ways! Make sure the payload is disassembled or tooling is properly supported; otherwise, fast downward movements of axis 3 may cause severe hits.	
3	Release the holding brake by pressing the button on the internal brake release unit.	 xx1500002774
4	Move the upper arm to a position where the axis 3 can be moved in full stroke.	
5	Move the shaft manually to its upper limit while pressing the brake release button.	 xx1500002790
6	Wipe off old grease from the shaft.	
7	Apply new grease and fill the grooves. Wipe off excessive grease.	
8	Move the shaft manually to its lower limit while pressing the brake release button.	 xx1500002791
9	Wipe off old grease from the shaft.	
10	Apply new grease and fill the grooves. Wipe off excessive grease.	

Continues on next page

	Action	Note
11	Move the shaft up and down several times while pressing the brake release button to smooth out the grease on the shaft. Wipe off excessive grease.	

## 3 Maintenance

---

### 3.7.1 Cleaning the IRB 910SC

## 3.7 Cleaning activities

### 3.7.1 Cleaning the IRB 910SC



#### DANGER

Turn off all:

- electric power supply
- hydraulic pressure supply
- air pressure supply

to the robot, before entering the safeguarded space.

---

#### General

To secure high uptime it is important that the IRB 910SC is cleaned regularly. The frequency of cleaning depends on the environment in which the product works. Different cleaning methods are allowed depending on the type of protection of the IRB 910SC.



#### Note

Always verify the protection type of the robot before cleaning.

---

#### Special cleaning considerations

This section specifies some special considerations when cleaning the robot.

- Always use cleaning equipment as specified. Any other cleaning equipment may shorten the life of the robot.
- Always check that all protective covers are fitted to the robot before cleaning.
- Never point the water jet at connectors, joints, sealings, or gaskets.
- Do not use compressed air to clean the robot.
- Never use solvents that are not approved by ABB to clean the robot.
- Do not spray from a distance closer than 0.4 m.
- Do not remove any covers or other protective devices before cleaning the robot.

---

#### Cleaning methods

The following table defines what cleaning methods are allowed depending on the protection type.

Protection type	Cleaning method			
	Vacuum cleaner	Wipe with cloth	Rinse with water	High pressure water or steam
Standard IP20	Yes	Yes. With light cleaning detergent.	No	No

*Continues on next page*



#### Cables

Movable cables need to be able to move freely:

- Remove waste material, such as sand, dust and chips, if it prevents cable movement.
- Clean the cables if they have a crusty surface, for example from dry release agents.

**This page is intentionally left blank**

## 4 Repair

### 4.1 Introduction

#### Structure of this chapter

This chapter describes repair activities for the IRB 910SC. Each procedure contains the information required to perform the activity, for example spare parts numbers, required special tools, and materials.



#### WARNING

Repair activities not described in this chapter must only be carried out by ABB.

#### Report replaced units



#### Note

When replacing a part on the IRB 910SC, report to your local ABB the serial number, the article number, and the revision of both the replaced unit and the replacement unit.

This is particularly important for safety equipment to maintain the safety integrity of the installation.

#### Safety information

Make sure to read through the chapter [Safety on page 17](#) before commencing any service work.



#### Note

If the IRB 910SC is connected to power, always make sure that the IRB 910SC is connected to protective earth and a residual current device (RCD) before starting any repair work.

For more information see:

- *Product manual - IRC5 Compact*

## 4 Repair

### 4.2.1 Cut the paint or surface on the robot before replacing parts

## 4.2 General procedures

### 4.2.1 Cut the paint or surface on the robot before replacing parts

#### General

Follow the procedures in this section whenever breaking the paint of the robot during replacement of parts.

#### Required equipment

Equipment	Spare parts	Note
Cleaning agent		Ethanol
Knife		
Lint free cloth		
Touch up paint Standard/Foundry Plus	3HAC067974-001	Graphite White

#### Removing

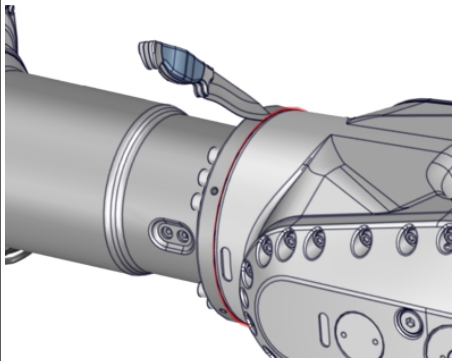
	Action	Description
1	Cut the paint with a knife in the joint between the part that will be removed and the structure, to avoid that the paint cracks.	 xx230000950
2	Carefully grind the paint edge that is left on the structure to a smooth surface.	

## 4.2.2 Mounting instructions for sealings

### General

This section describes how to mount different types of sealings.

### Equipment

Consumable	Article number	Note
Grease	3HAC042536-001	Shell Gadus S2

### Rotating sealings

The following procedures describe how to fit rotating sealings.



#### CAUTION

Please observe the following before commencing any assembly of sealings:

- Protect the sealing during transport and mounting, especially the main lip on radial sealings.
- Keep the sealing in its original wrappings or protect it well before actual mounting.
- The fitting of sealings and gears must be carried out on clean workbenches.
- Use a protective sleeve for the main lip during mounting, when sliding over threads, keyways or other sharp edges.
- Do not lubricate a static side of a sealing with grease, since this may result in movement of the sealing during operation.

The only exception for lubrication of static sides of a sealing, is to use P-80 rubber lubrication gel against certain aluminium surfaces. If usage of P-80 is relevant, it is stated in the repair procedures.

### Radial sealings

A radial sealing consists of a flexible rubber lip bonded to a rigid metal case. Only one side of the sealing is static with a metal insert.

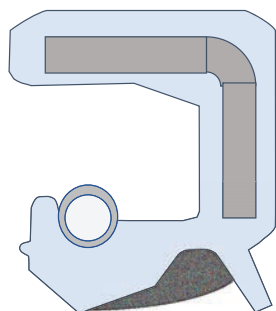



xx230000433

*Continues on next page*

## 4 Repair

### 4.2.2 Mounting instructions for sealings

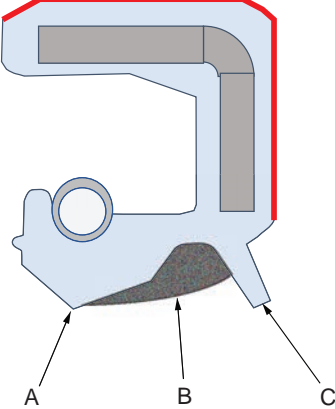
Continued

	Action	Note
1	Check the sealing to ensure that: <ul style="list-style-type: none"> <li>• The sealing is of the correct type.</li> <li>• There is no damage on the main lip.</li> </ul>	
2	Inspect the shaft surface before mounting. If scratches or damage are found, the shaft must be replaced since it may result in future leakage. Do not try to grind or polish the shaft surface to get rid of the defect.	
3	Lubricate the sealing with grease just before fitting. (Not too early - there is a risk of dirt and foreign particles adhering to the sealing.) Fill 2/3 of the space between the dust lip and the main lip with grease. If the sealing is without dust lip, just lubricate the main lip with a thin layer of grease.	<p>Article number is specified in <a href="#">Equipment on page 121</a>.</p>  <p>xx200000071</p> <p>A Main lip B Grease C Dust lip</p> <p> <b>Note</b></p> <p>Ensure that no grease is applied to the red marked surface.</p>

Continues on next page

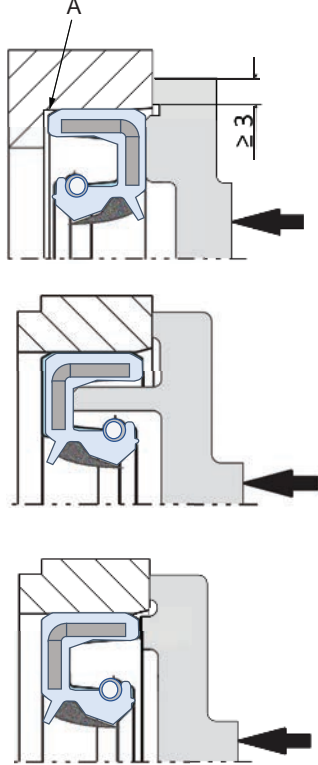
	Action	Note
4	Mount the sealing correctly with a mounting tool. Never hammer directly on the sealing as this may result in leakage.	 <p data-bbox="1093 1122 1203 1144">xx200000072</p> <p data-bbox="1129 1155 1214 1178">A Gap</p>

**Flange sealings and static sealings**

The following procedure describes how to fit flange sealings and static sealings.

	Action
1	Check the flange surfaces. They must be even and free from pores. It is easy to check flatness using a gauge on the fastened joint (without sealing compound). If the flange surfaces are defective, the parts may not be used because leakage could occur.
2	Clean the surfaces properly in accordance with the recommendations of ABB.
3	Distribute the sealing compound evenly over the surface.
4	Tighten the screws evenly when fastening the flange joint.

**O-rings**

The following procedure describes how to fit o-rings.

	Action	Note
1	Ensure that the correct o-ring size is used.	
2	Check the o-ring for surface defects, burrs, shape accuracy, or deformation.	Defective o-rings, including damaged or deformed o-rings, may not be used.

*Continues on next page*

## 4 Repair

---

### 4.2.2 Mounting instructions for sealings

*Continued*

	Action	Note
3	Check the o-ring grooves and mating surfaces. They should be free of pores, contamination and obvious scratches/damage.	
4	Lubricate the o-ring with grease.	
5	Tighten the screws evenly while assembling.	
6	Check that the o-ring is not squashed outside the o-ring groove.	



4.3 Cable harness

4.3.1 Replacing the main cable package

Location of the main cable package

The main cable package is located as shown in the figure.

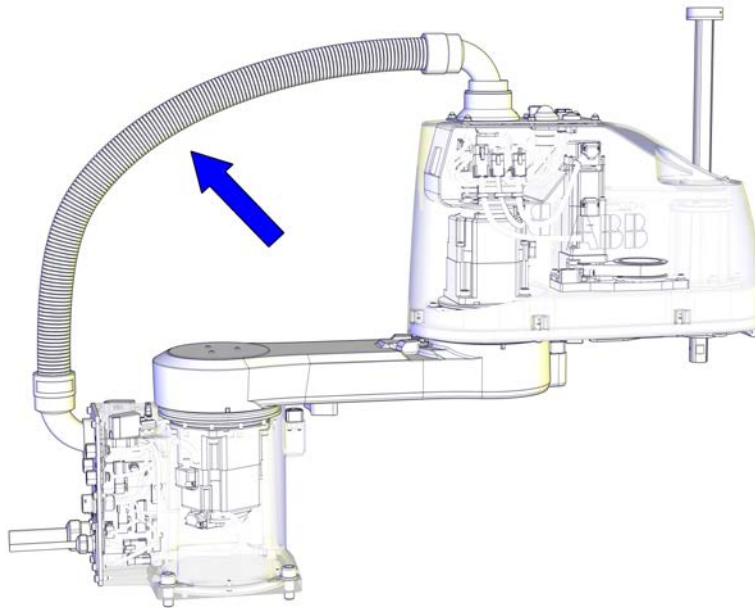

xx1500002172

Required spare parts



Note

The spare part numbers that are listed in the table can be out of date. See the latest spare parts of the IRB 910SC via myABB Business Portal, [www.abb.com/myABB](http://www.abb.com/myABB).

Spare part	Article number	Note
Main cable, 450 mm	3HAC056165-001	
Main cable, 550 mm	3HAC056080-001	
Main cable, 650 mm	3HAC056166-001	
EIB connection cable	3HAC056703-001	Replace if damaged.

Required tools and equipment

Equipment	Article number	Note
Standard toolkit	-	Content is defined in section <a href="#">Standard toolkit on page 392</a> .

Continues on next page

## 4 Repair

### 4.3.1 Replacing the main cable package

*Continued*



#### Required consumables

Consumable	Article number	Note
Shrink hose	-	Used for protecting the PCB board.
Cable ties	-	

#### Removing the main cable package

Use these procedures to remove the main cable package.

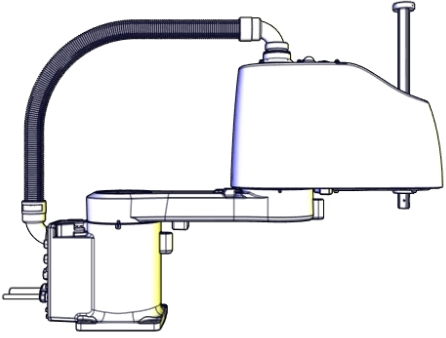
#### Preparations before removing the main cable package





	Action	Note
1	Jog all axes to zero position.	 xx1500002227
2	 <b>DANGER</b> Turn off all: <ul style="list-style-type: none"><li>• electric power supply</li><li>• hydraulic pressure supply</li><li>• air pressure supply</li></ul> to the robot, before entering the robot working area.	

#### Removing the main cable package from the upper arm

	Action	Note
1	 <b>DANGER</b> Make sure that all supplies for electrical power, hydraulic pressure, and air pressure are turned off.	

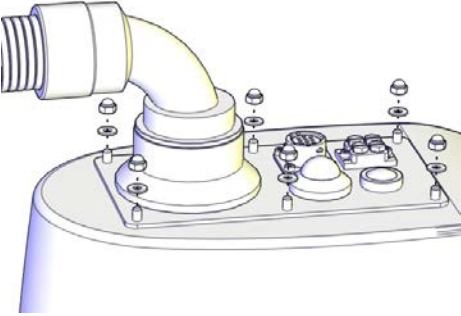
*Continues on next page*

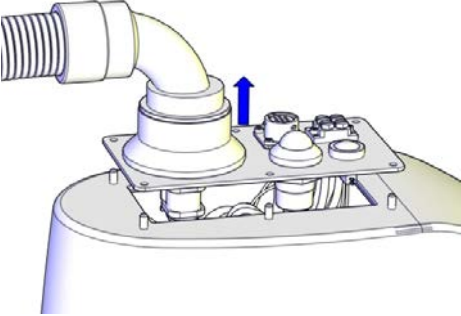
4.3.1 Replacing the main cable package  
Continued

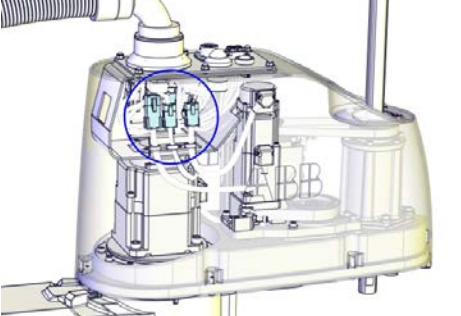
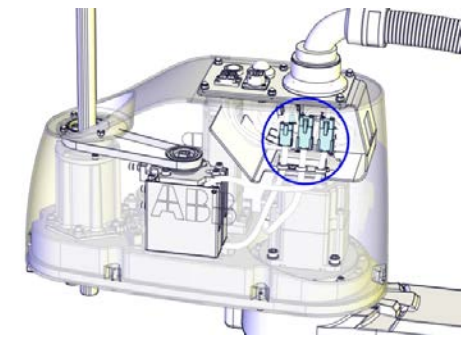
	Action	Note
2	Remove the dome nuts and washers.	 <p>xx1500002182</p>
3	Carefully open the user interface plate and pull out the cable package.   <b>CAUTION</b>  The plate cannot be removed completely until the connectors are disconnected, as shown in the following step.	 <p>xx1500002183</p>
4	Disconnect the connectors: <ul style="list-style-type: none"> <li>• R2.MP2</li> <li>• R2.MP3</li> <li>• R2.MP4</li> <li>• R2.ME2</li> <li>• R2.ME3</li> <li>• R2.ME4</li> </ul>  <b>Tip</b>  Take photos of the connectors and cable position before disconnecting them, to have as a reference when reconnecting.	 <p>xx1500002184</p>  <p>xx1500002185</p>





Continues on next page

## 4 Repair

### 4.3.1 Replacing the main cable package

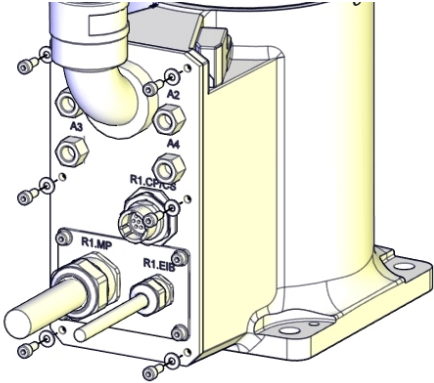

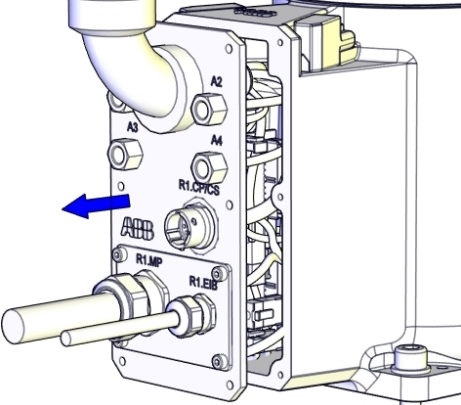
*Continued*

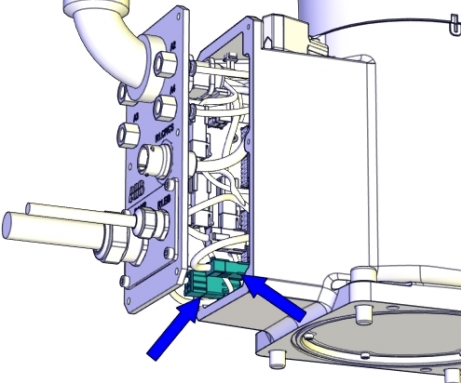
#### Removing the main cable package from the base

	Action	Note
1	 <p><b>DANGER</b></p> <p>Make sure that all supplies for electrical power, hydraulic pressure, and air pressure are turned off.</p>	
2	Remove the screws and washers.	 <p>xx1500002186</p>
3	<p>Carefully open the base cover and pull out the cable package.</p> <p> <b>CAUTION</b></p> <p>The cover cannot be removed completely until the connectors are disconnected.</p> <p> <b>CAUTION</b></p> <p>Clean cover from metal residues before opening.</p> <p>Metal residues can cause shortage on the boards which can result in hazardous failures.</p>	 <p>xx1500002187</p>
4	<p>Disconnect the connectors:</p> <ul style="list-style-type: none"> <li>• R2.MP1</li> <li>• R2.ME1</li> </ul> <p> <b>Tip</b></p> <p>Take photos of the connectors and cable position before disconnecting them, to have as a reference when reconnecting.</p>	 <p>xx1500002188</p>

*Continues on next page*

Removing the PCB board

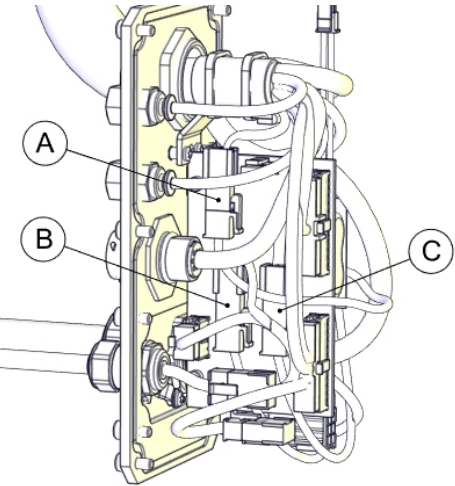
	Action	Note						
1	 <p><b>DANGER</b></p> <p>Make sure that all supplies for electrical power, hydraulic pressure, and air pressure are turned off.</p>							
2	 <p><b>ELECTROSTATIC DISCHARGE (ESD)</b></p> <p>The unit is sensitive to ESD. Before handling the unit please read the safety information in the section <i>The unit is sensitive to ESD on page 53</i></p>							
3	<p>Disconnect the connectors:</p> <ul style="list-style-type: none"> <li>• R1.BK1-2</li> <li>• R1.DBP</li> <li>• R2.BK1-2</li> </ul> <p> <b>Tip</b></p> <p>Take photos of the connectors and cable position before disconnecting them, to have as a reference when reconnecting.</p>	 <p>xx1500002190</p> <table border="1" data-bbox="976 1339 1433 1473"> <tbody> <tr> <td>A</td> <td>R1.BK1-2</td> </tr> <tr> <td>B</td> <td>R1.DBP</td> </tr> <tr> <td>C</td> <td>R2.BK1-2</td> </tr> </tbody> </table>	A	R1.BK1-2	B	R1.DBP	C	R2.BK1-2
A	R1.BK1-2							
B	R1.DBP							
C	R2.BK1-2							

Continues on next page



## 4 Repair

### 4.3.1 Replacing the main cable package

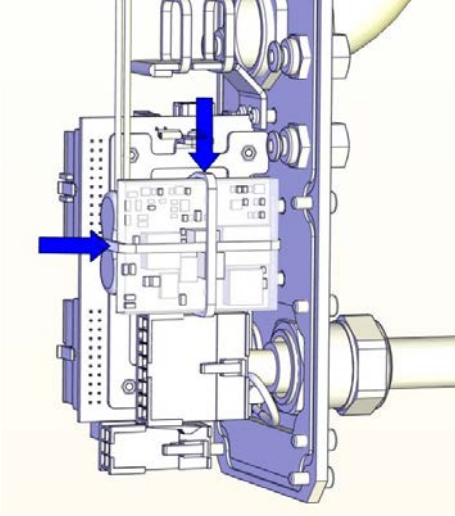
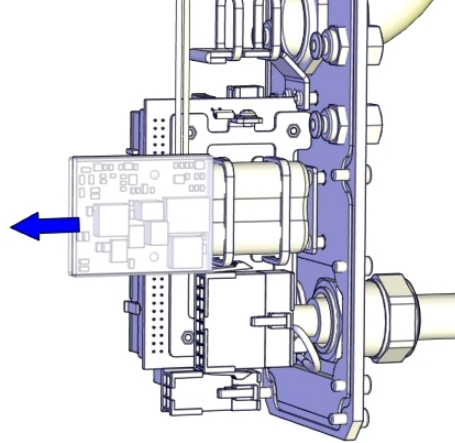
Continued

	Action	Note
4	Cut the cable ties.	 <p data-bbox="943 831 1050 853">xx1500002752</p>
5	Remove the PCB board carefully.	 <p data-bbox="943 1346 1050 1368">xx1500002191</p>

### Disconnecting the battery cable



	Action	Note
1	 <p data-bbox="555 1547 667 1576"><b>DANGER</b></p> <p data-bbox="464 1610 933 1688">Make sure that all supplies for electrical power, hydraulic pressure, and air pressure are turned off.</p>	
2	 <p data-bbox="555 1747 916 1805"><b>ELECTROSTATIC DISCHARGE (ESD)</b></p> <p data-bbox="464 1821 933 1928">The unit is sensitive to ESD. Before handling the unit please read the safety information in the section <a href="#">The unit is sensitive to ESD on page 53</a></p>	

Continues on next page

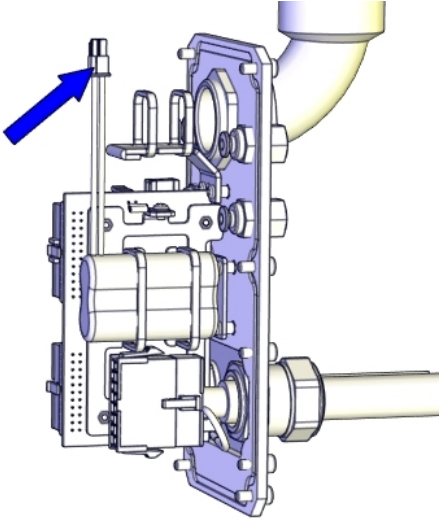
4.3.1 Replacing the main cable package  
Continued

	Action	Note
3	Disconnect the battery cable.	 <p>xx1500002192</p>

Removing the battery pack

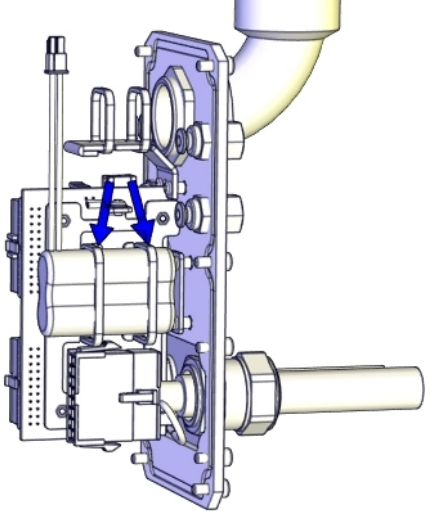
	Action	Note
1	 <p><b>DANGER</b></p> <p>Make sure that all supplies for electrical power, hydraulic pressure, and air pressure are turned off.</p>	
2	 <p><b>ELECTROSTATIC DISCHARGE (ESD)</b></p> <p>The unit is sensitive to ESD. Before handling the unit please read the safety information in the section <a href="#">The unit is sensitive to ESD on page 53</a></p>	
3	Cut the cable ties.	 <p>xx1500002193</p>

Continues on next page



## 4 Repair

### 4.3.1 Replacing the main cable package

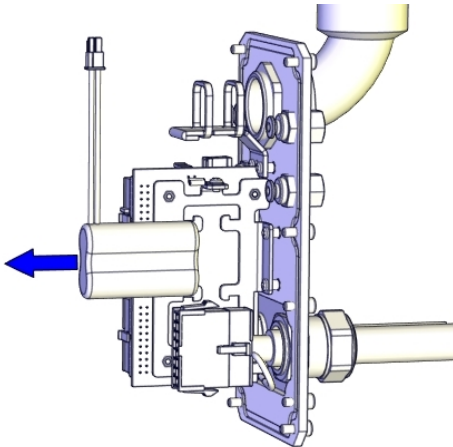
*Continued*

	Action	Note
4	<p>Remove the battery.</p> <p> <b>Note</b></p> <p>Battery includes protection circuits. Only replace with a specified spare part or with an ABB- approved equivalent.</p>	 <p>xx1500002194</p>

### Removing the EIB unit

	Action	Note
1	<p> <b>DANGER</b></p> <p>Make sure that all supplies for electrical power, hydraulic pressure, and air pressure are turned off.</p>	
2	<p> <b>ELECTROSTATIC DISCHARGE (ESD)</b></p> <p>The unit is sensitive to ESD. Before handling the unit please read the safety information in the section <a href="#">The unit is sensitive to ESD on page 53</a></p>	

*Continues on next page*



4.3.1 Replacing the main cable package

*Continued*

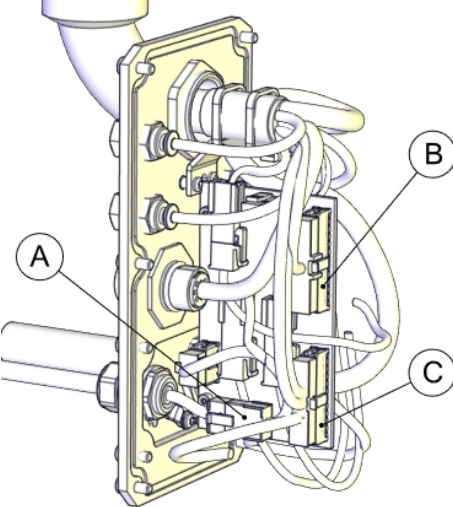
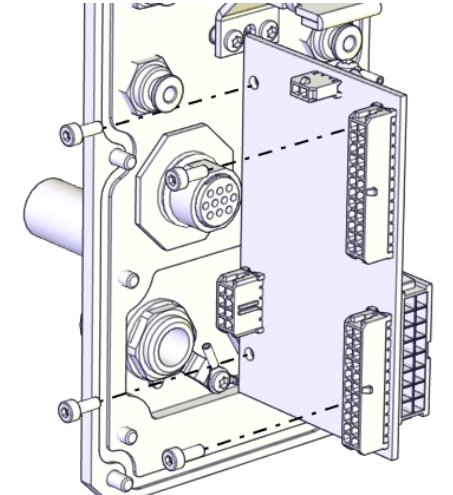
	Action	Note						
3	Disconnect the connectors: <ul style="list-style-type: none"> <li>• R1.EIB</li> <li>• R1.ME4</li> <li>• R1.ME1-3</li> </ul>	 <p>xx1500002195</p> <table border="1" data-bbox="973 869 1428 1003"> <tr> <td>A</td> <td>R1.EIB</td> </tr> <tr> <td>B</td> <td>R1.ME4</td> </tr> <tr> <td>C</td> <td>R1.ME1-3</td> </tr> </table>	A	R1.EIB	B	R1.ME4	C	R1.ME1-3
A	R1.EIB							
B	R1.ME4							
C	R1.ME1-3							
4	Remove the screws.	 <p>xx1500002792</p>						

*Continues on next page*

## 4 Repair

### 4.3.1 Replacing the main cable package

Continued

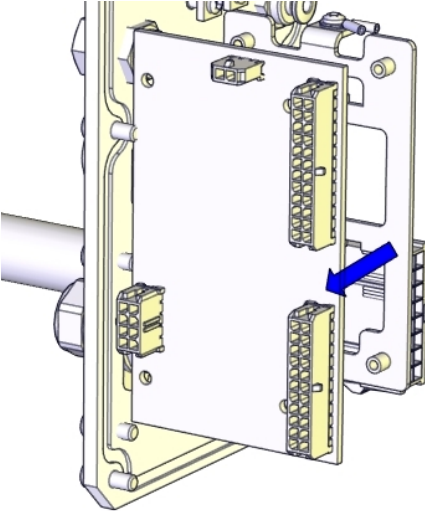
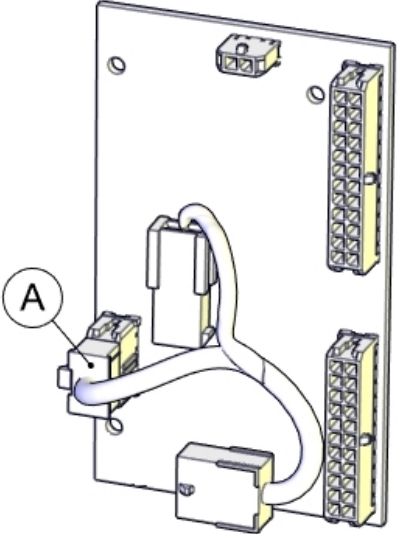
	Action	Note		
5	Remove the EIB unit.	 <p>xx1500002196</p>		
6	Disconnect the connector to remove the EIB connection cable. <ul style="list-style-type: none"> <li>• R2.EIB</li> </ul>	 <p>xx1500002197</p> <table border="1" data-bbox="943 1525 1401 1570"> <tr> <td data-bbox="943 1525 991 1570">A</td> <td data-bbox="995 1525 1401 1570">R2.EIB</td> </tr> </table>	A	R2.EIB
A	R2.EIB			

#### Removing the EIB mounting plate

	Action	Note
1	 <p><b>DANGER</b></p> <p>Make sure that all supplies for electrical power, hydraulic pressure, and air pressure are turned off.</p>	

Continues on next page

### 4.3.1 Replacing the main cable package Continued

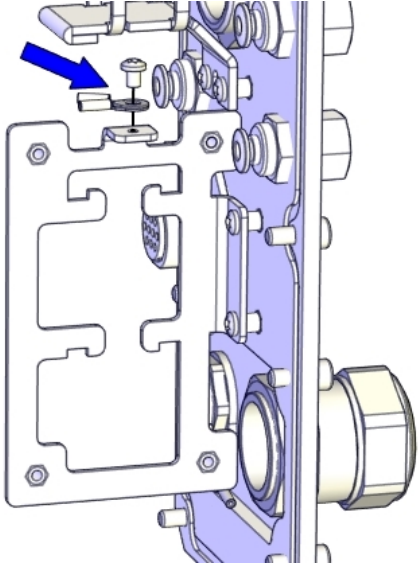
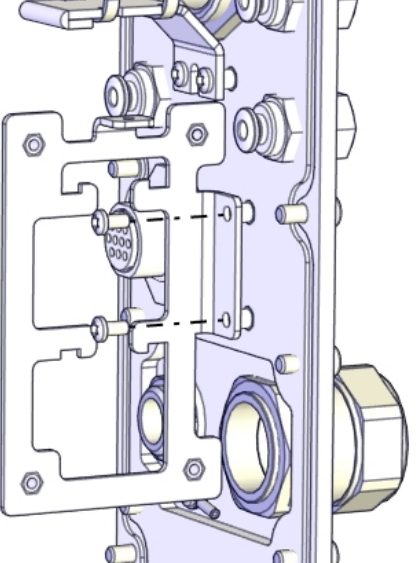
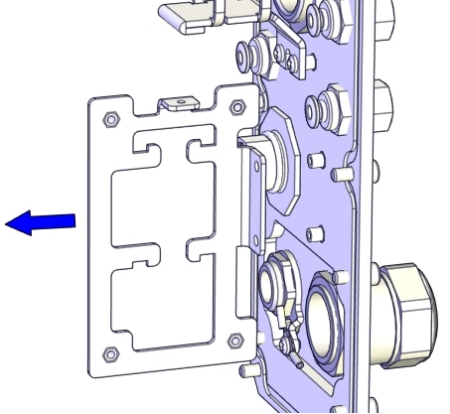
	Action	Note
2	Disconnect the earth cable by removing the screw.	 <p>xx1500002794</p>
3	Remove the screws.	 <p>xx1500002795</p>
4	Remove the EIB mounting plate.	 <p>xx1500002198</p>

Continues on next page

## 4 Repair

### 4.3.1 Replacing the main cable package

*Continued*

#### Removing the floor cables

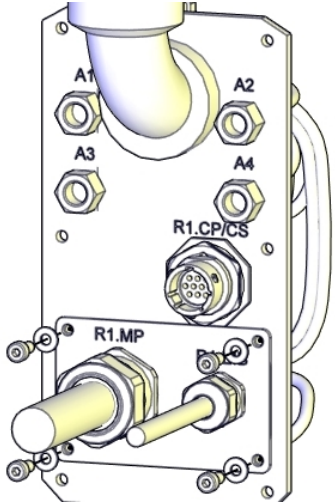
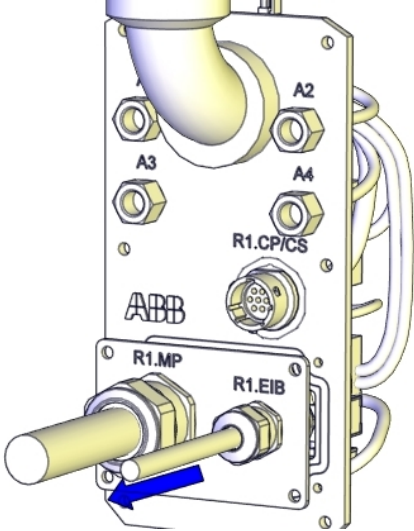
	Action	Note
1	 <b>DANGER</b> Make sure that all supplies for electrical power, hydraulic pressure, and air pressure are turned off.	
2	Remove the screws and washers.	 xx1500002199
3	Pull out the floor cables.	 xx1500002200

#### Disconnecting the floor cable connector

	Action	Note
1	 <b>DANGER</b> Make sure that all supplies for electrical power, hydraulic pressure, and air pressure are turned off.	

*Continues on next page*

**4.3.1 Replacing the main cable package**

*Continued*

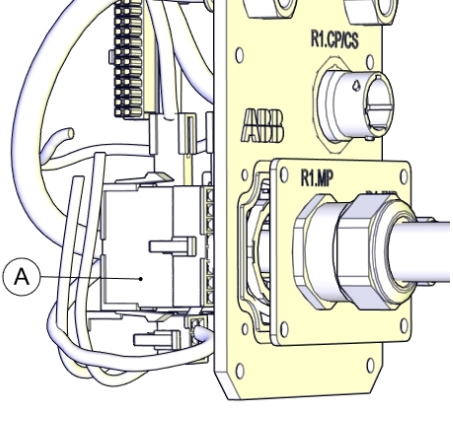
	Action	Note		
2	Disconnect the connector: <ul style="list-style-type: none"> <li>• R1.MP</li> </ul>	 <p>xx1500002201</p> <table border="1" data-bbox="975 770 1441 813"> <tr> <td data-bbox="975 770 1027 813">A</td> <td data-bbox="1027 770 1441 813">R1.MP</td> </tr> </table>	A	R1.MP
A	R1.MP			

**Refitting the main cable package**

Use these procedures to refit the main cable package.

**Reconnecting the floor cable connector**

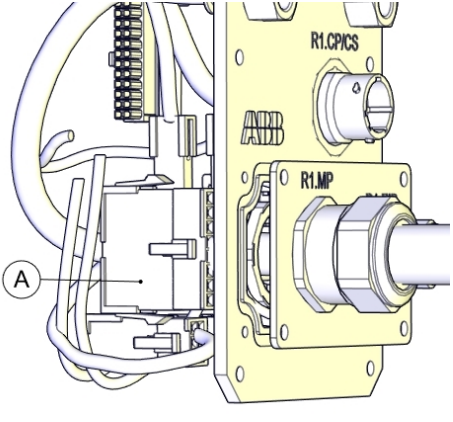
	Action	Note		
1	Reconnect the connector. <ul style="list-style-type: none"> <li>• R1.MP</li> </ul>	 <p>xx1500002201</p> <table border="1" data-bbox="975 1527 1441 1570"> <tr> <td data-bbox="975 1527 1027 1570">A</td> <td data-bbox="1027 1527 1441 1570">R1.MP</td> </tr> </table>	A	R1.MP
A	R1.MP			

*Continues on next page*

## 4 Repair

### 4.3.1 Replacing the main cable package

*Continued*

#### Refitting the floor cables

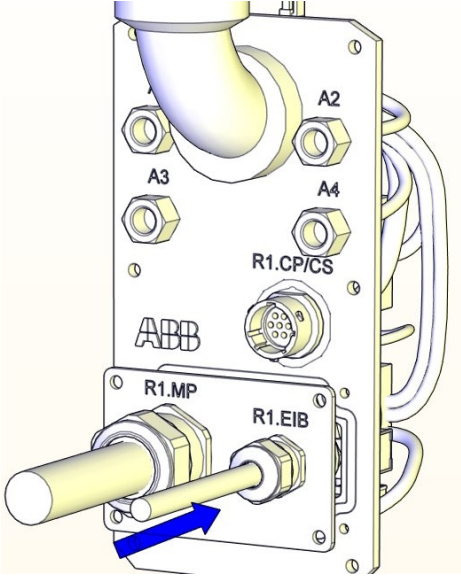
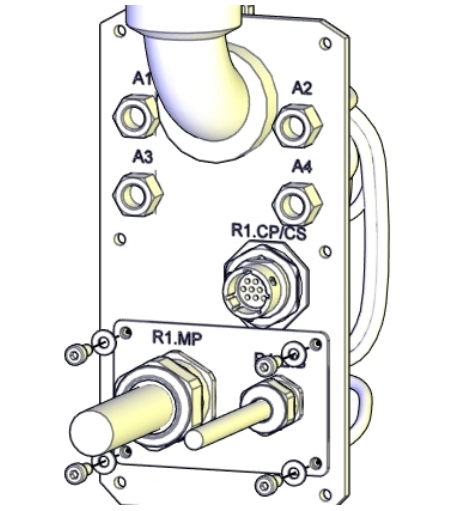
	Action	Note
1	Push the floor cables into place.	 <p>xx1500002208</p>
2	Secure with screws and washers.	 <p>xx1500002199</p> <p>Screw: M4x10 (4 pcs) Tightening torque: 2 Nm</p>

*Continues on next page*

**Refitting the EIB mounting plate**

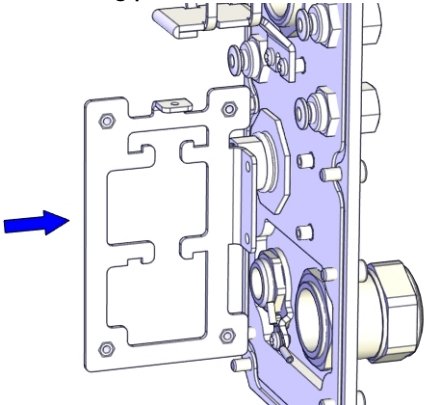
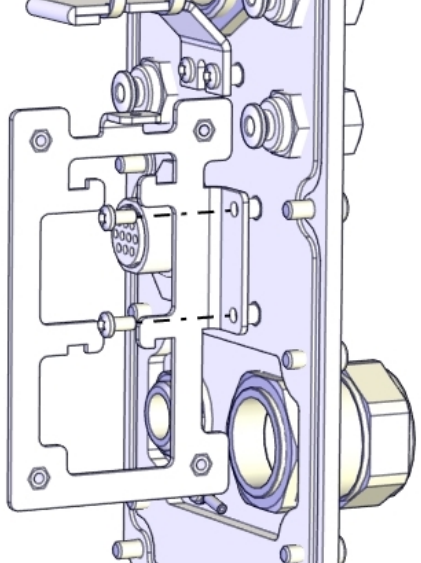
	<b>Action</b>	<b>Note</b>
1	Refit the EIB mounting plate.	<p>EIB mounting plate: 3HAC055165-001</p>  <p>xx1500002796</p>
2	Secure with screws.	 <p>xx1500002795</p> <p>Screw: M3x6 (2 pcs)                      Tightening torque: 1.5 Nm</p>

*Continues on next page*

## 4 Repair

### 4.3.1 Replacing the main cable package

Continued

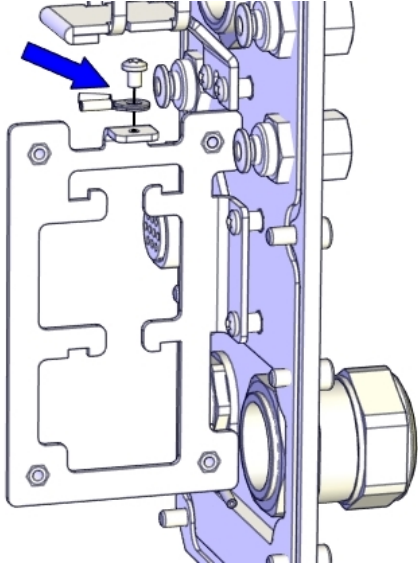
	Action	Note
3	Connect the earth cable with the screw.	 <p data-bbox="943 880 1050 898">xx1500002794</p> <p data-bbox="943 913 1166 943">Screw: M3x4 (1 pcs)</p> <p data-bbox="943 949 1230 978">Tightening torque: 0.3 Nm</p>

### Refitting the EIB unit

	Action	Note
1	 <b>ELECTROSTATIC DISCHARGE (ESD)</b> The unit is sensitive to ESD. Before handling the unit please read the safety information in the section <a href="#">The unit is sensitive to ESD on page 53</a>	

Continues on next page



4.3.1 Replacing the main cable package  
Continued

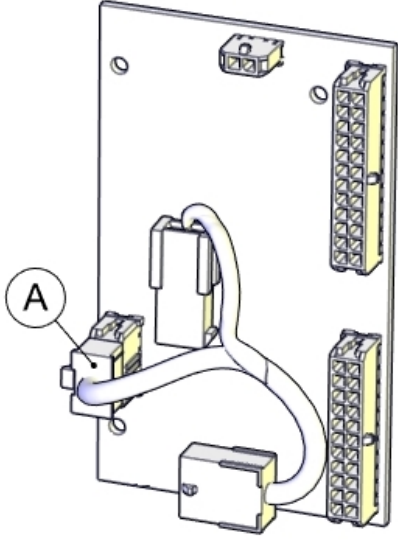
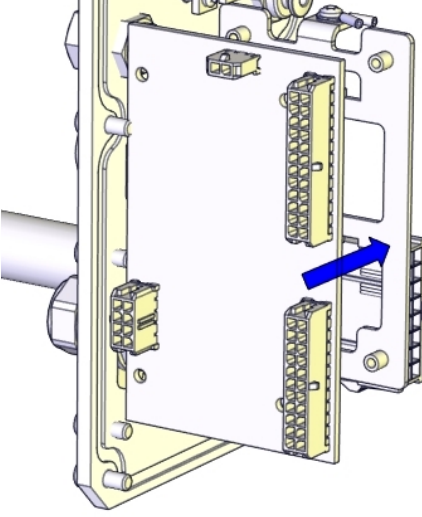

	Action	Note		
2	<p>Reconnect the connector to refit the EIB connection cable.</p> <ul style="list-style-type: none"> <li>• R2.EIB</li> </ul> <p> <b>CAUTION</b></p> <p>The EIB connection cable has one connector at one end and two connectors at the other end.</p> <p>Make sure not to mix the connectors. See the labels on the connectors for correct connection.</p>	<p>EIB connection cable: 3HAC056703-001</p>  <p>xx1500002197</p> <table border="1" data-bbox="973 981 1436 1030"> <tr> <td data-bbox="973 981 1029 1030">A</td> <td data-bbox="1029 981 1436 1030">R2.EIB</td> </tr> </table>	A	R2.EIB
A	R2.EIB			
3	<p>Refit the EIB unit.</p>	 <p>xx1500002793</p>		

Continues on next page

## 4 Repair

### 4.3.1 Replacing the main cable package

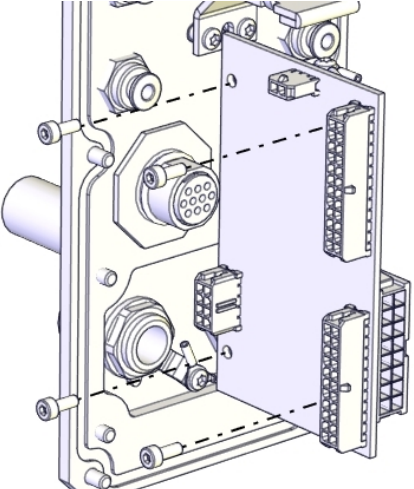
Continued

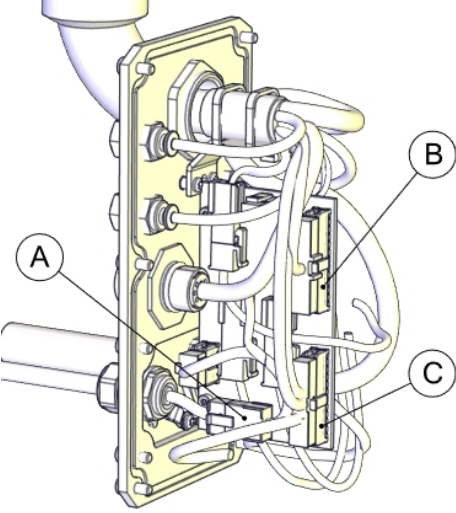
	Action	Note						
4	Secure with screws.	 <p data-bbox="943 808 1050 826">xx1500002792</p> <p data-bbox="943 846 1233 909">Screw: M3x8 (4 pcs) Tightening torque: 0.3 Nm</p>						
5	Reconnect the connectors. <ul style="list-style-type: none"> <li>• R1.EIB</li> <li>• R1.ME4</li> <li>• R1.ME1-3</li> </ul>  <p data-bbox="557 1081 671 1108"><b>CAUTION</b></p> <p data-bbox="464 1137 933 1240">Make sure not to mix the connectors; otherwise, axes may be damaged. See the labels on the connectors for correct connection.</p>	 <p data-bbox="943 1444 1050 1462">xx1500002195</p> <table border="1" data-bbox="943 1480 1404 1619"> <tbody> <tr> <td data-bbox="943 1480 991 1525">A</td> <td data-bbox="995 1480 1404 1525">R1.EIB</td> </tr> <tr> <td data-bbox="943 1532 991 1576">B</td> <td data-bbox="995 1532 1404 1576">R1.ME4</td> </tr> <tr> <td data-bbox="943 1583 991 1628">C</td> <td data-bbox="995 1583 1404 1628">R1.ME1-3</td> </tr> </tbody> </table>	A	R1.EIB	B	R1.ME4	C	R1.ME1-3
A	R1.EIB							
B	R1.ME4							
C	R1.ME1-3							

### Refitting the battery pack

	Action	Note
1	 <p data-bbox="557 1783 916 1841"><b>ELECTROSTATIC DISCHARGE (ESD)</b></p> <p data-bbox="464 1861 933 1966">The unit is sensitive to ESD. Before handling the unit please read the safety information in the section <a href="#">The unit is sensitive to ESD on page 53</a></p>	

Continues on next page

4.3.1 Replacing the main cable package  
Continued

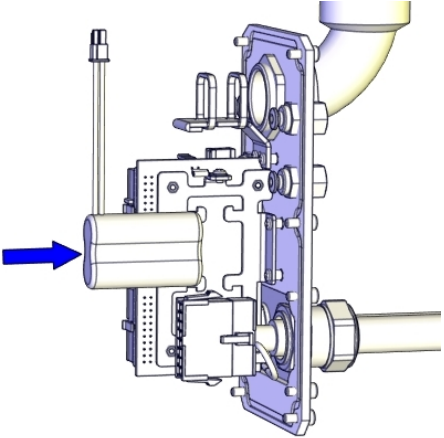
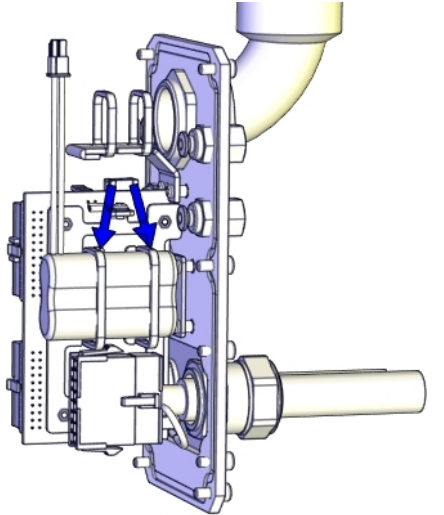
	Action	Note
2	Fit the battery.   <b>Note</b>  Battery includes protection circuits. Only replace with a specified spare part or with an ABB- approved equivalent.	  xx1500002206
3	Secure the battery with cable ties.	  xx1500002193

Connecting the battery cable

	Action	Note
1	 <b>ELECTROSTATIC DISCHARGE (ESD)</b>  The unit is sensitive to ESD. Before handling the unit please read the safety information in the section <i>The unit is sensitive to ESD on page 53</i>	

Continues on next page



## 4 Repair

### 4.3.1 Replacing the main cable package

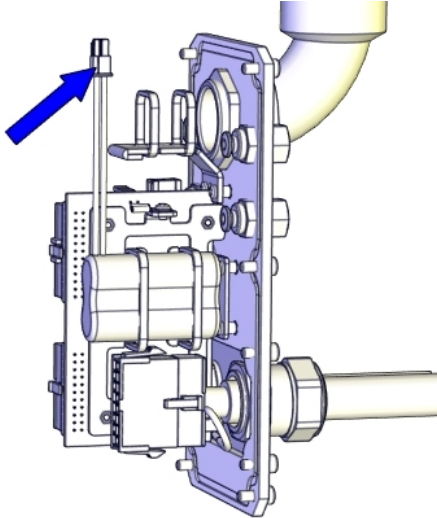
Continued

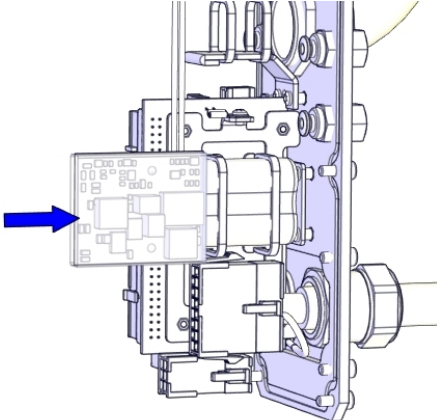

	Action	Note
2	Connect the battery cable.	 <p data-bbox="936 837 1050 860">xx1500002192</p>

### Refitting the PCB board

	Action	Note
1	 <p data-bbox="555 1028 916 1088"><b>ELECTROSTATIC DISCHARGE (ESD)</b></p> <p data-bbox="464 1106 932 1211">The unit is sensitive to ESD. Before handling the unit please read the safety information in the section <i>The unit is sensitive to ESD on page 53</i></p>	
2	<p data-bbox="464 1247 699 1276">Refit the PCB board.</p>  <p data-bbox="555 1308 616 1337"><b>Note</b></p> <p data-bbox="464 1361 932 1420">The PCB board is protected by shrink hose. Replace the hose if damaged.</p>	<p data-bbox="936 1247 1270 1276">PCB board: 3HAC057687-001</p>  <p data-bbox="936 1715 1050 1738">xx1500002205</p>

Continues on next page

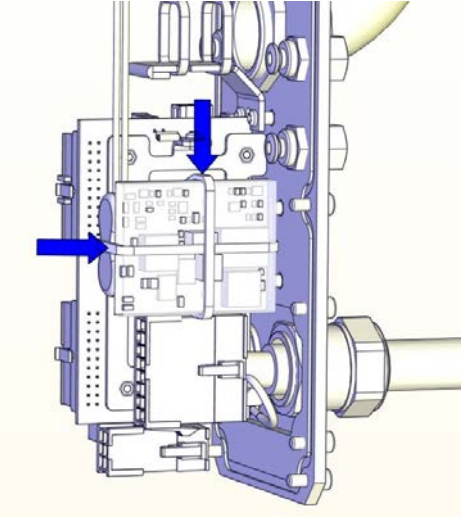
4.3.1 Replacing the main cable package  
Continued

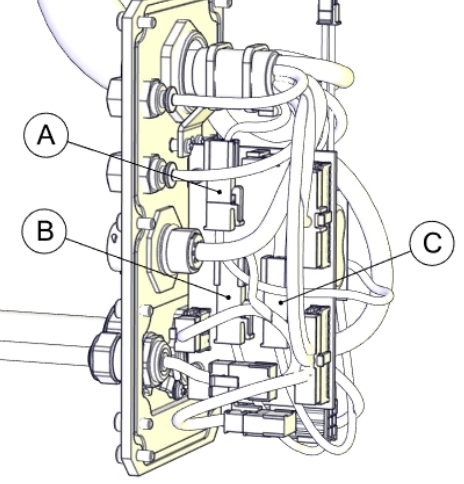
	Action	Note						
3	Secure the PCB board with cable ties. Do not tighten the ties too tight.	 <p>xx1500002752</p>						
4	Reconnect the connectors. <ul style="list-style-type: none"> <li>• R1.BK1-2</li> <li>• R1.DBP</li> <li>• R2.BK1-2</li> </ul>  <b>CAUTION</b> Make sure not to mix the connectors. See the labels on the connectors for correct connection.	 <p>xx1500002190</p> <table border="1" data-bbox="975 1413 1441 1552"> <tbody> <tr> <td>A</td> <td>R1.BK1-2</td> </tr> <tr> <td>B</td> <td>R1.DBP</td> </tr> <tr> <td>C</td> <td>R2.BK1-2</td> </tr> </tbody> </table>	A	R1.BK1-2	B	R1.DBP	C	R2.BK1-2
A	R1.BK1-2							
B	R1.DBP							
C	R2.BK1-2							
5	Secure the cables with cable ties if needed.							

Refitting the main cable to the base

	Action	Note
1	Secure the main cable package with cable ties if needed.	

Continues on next page

## 4 Repair

### 4.3.1 Replacing the main cable package

Continued

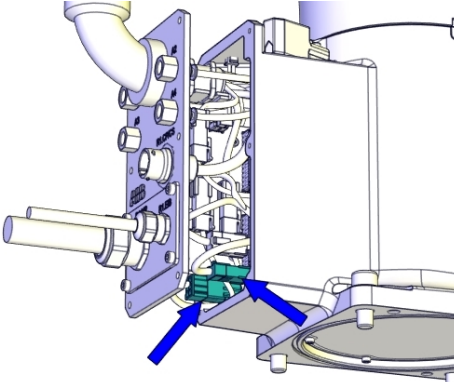
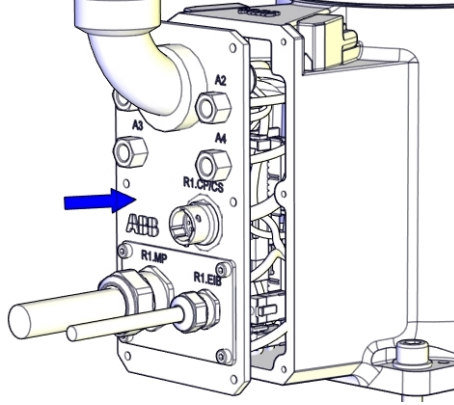
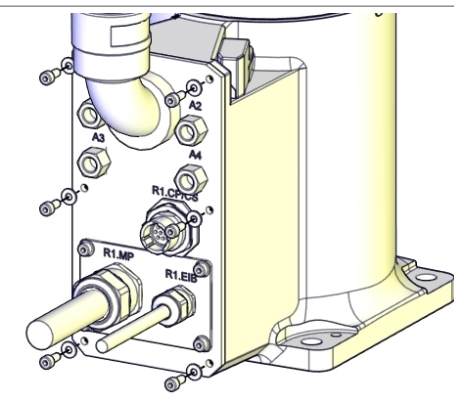
	Action	Note
2	Reconnect the connectors. <ul style="list-style-type: none"> <li>• R2.MP1</li> <li>• R2.ME1</li> </ul>	 <p>xx1500002188</p>
3	Push the main cable package into place.	 <p>xx1500002204</p>
4	Refit the base cover with screws and washers.	 <p>xx1500002186</p> <p>Screws: M4x10 (6 pcs) Tightening torque: 2 Nm</p>

#### Refitting the main cable to the upper arm

	Action	Note
1	Secure the main cable package with cable ties if needed.	

Continues on next page

4.3.1 Replacing the main cable package  
Continued

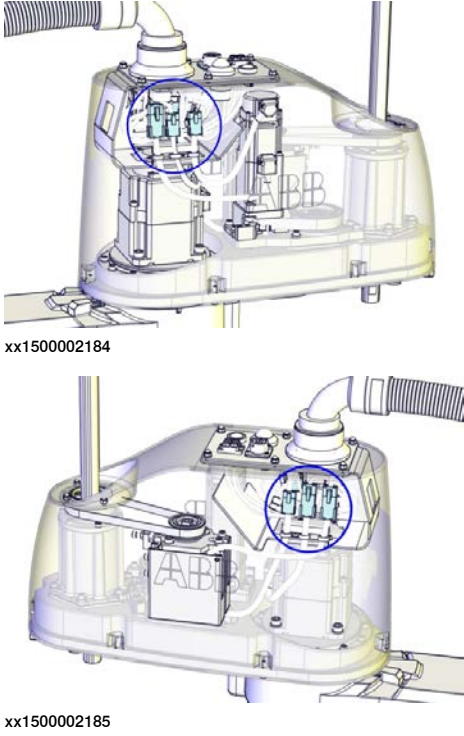
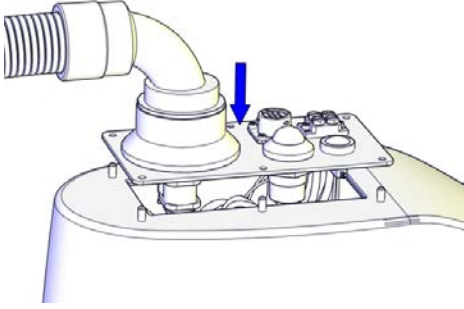
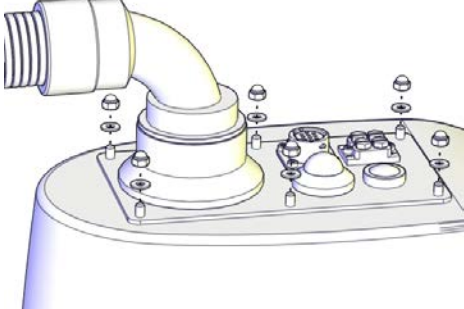
	Action	Note
2	<p>Reconnect the connectors.</p> <ul style="list-style-type: none"> <li>• R2.MP2</li> <li>• R2.MP3</li> <li>• R2.MP4</li> <li>• R2.ME2</li> <li>• R2.ME3</li> <li>• R2.ME4</li> </ul>	 <p>xx1500002184</p> <p>xx1500002185</p>
3	<p>Push the main cable package into place.</p>	 <p>xx1500002207</p>
4	<p>Refit the user interface plate.</p>	 <p>xx1500002182</p> <p>Dome nut: M4 (6 pcs) Tightening torque: 2 Nm Washer, 6 pcs</p>

Continues on next page

## 4 Repair

---

### 4.3.1 Replacing the main cable package

*Continued*

Concluding procedure

	Action	Note
1	Recalibrate the robot.	Calibration is detailed in section <a href="#">Calibration on page 349</a> .
2	 <b>DANGER</b> Make sure all safety requirements are met when performing the first test run. These are further detailed in the section "First test run may cause injury or damage" in <i>Safety manual for robot - Manipulator and IRC5 or OmniCore controller</i> .	



## 4.3.2 Replacing the EIB unit

### Location of the EIB unit

The EIB unit is located as shown in the figure.

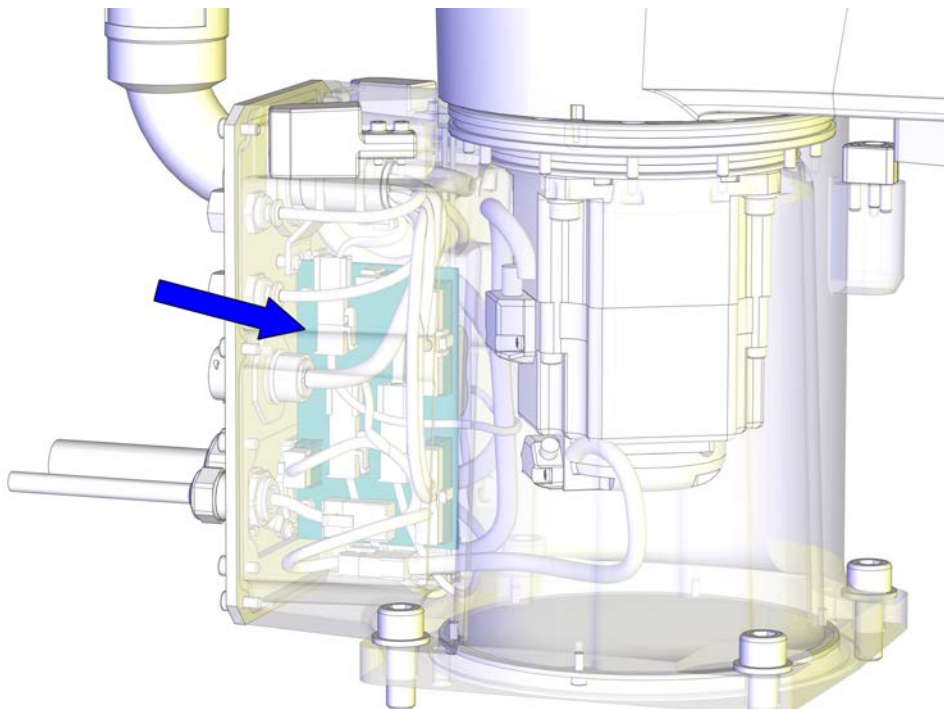

xx1500002178

### Required spare parts



#### Note

The spare part numbers that are listed in the table can be out of date. See the latest spare parts of the IRB 910SC via myABB Business Portal, [www.abb.com/myABB](http://www.abb.com/myABB).

Spare part	Article number	Note
EIB unit	3HAC045759-001	
EIB connection cable	3HAC056703-001	Replace if damaged.

### Required tools and equipment

Equipment	Article number	Note
Standard toolkit	-	Content is defined in section <a href="#">Standard toolkit on page 392</a> .

### Required consumables

Consumable	Article number	Note
Cable ties	-	

*Continues on next page*

## 4 Repair



### 4.3.2 Replacing the EIB unit

*Continued*

#### Removing the EIB unit

Use these procedures to remove the EIB unit.

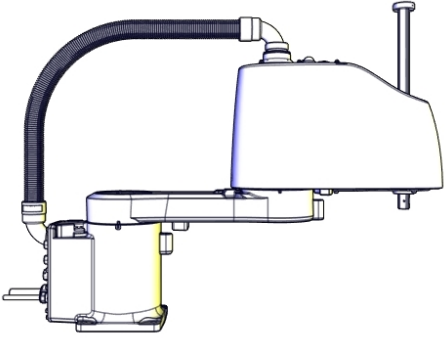

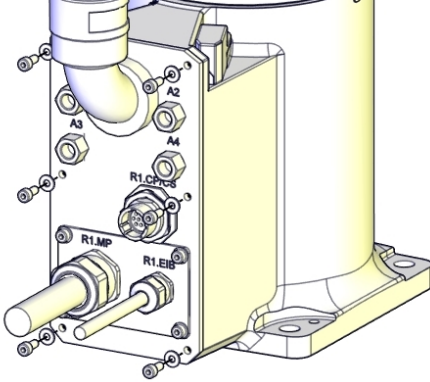

#### Preparations before removing the EIB unit

	Action	Note
1	Jog all axes to zero position.	 xx1500002227
2	 <b>DANGER</b> Turn off all: <ul style="list-style-type: none"> <li>• electric power supply</li> <li>• hydraulic pressure supply</li> <li>• air pressure supply</li> </ul> to the robot, before entering the robot working area.	

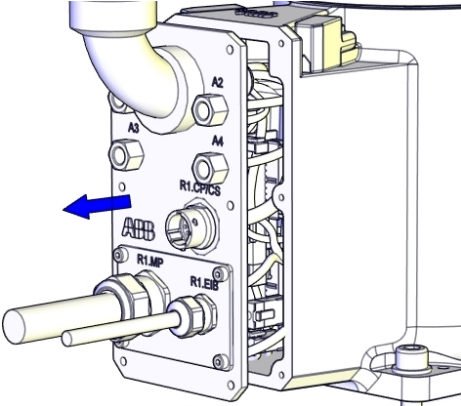

#### Removing the main cable package from the base

	Action	Note
1	 <b>DANGER</b> Make sure that all supplies for electrical power, hydraulic pressure, and air pressure are turned off.	
2	Remove the screws and washers.	 xx1500002186

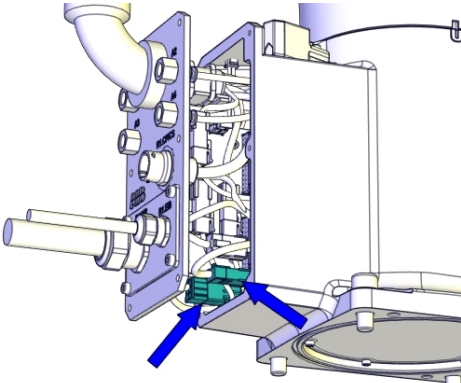
*Continues on next page*

	Action	Note
3	<p>Carefully open the base cover and pull out the cable package.</p> <p> <b>CAUTION</b></p> <p>The cover cannot be removed completely until the connectors are disconnected.</p> <p> <b>CAUTION</b></p> <p>Clean cover from metal residues before opening.</p> <p>Metal residues can cause shortage on the boards which can result in hazardous failures.</p>	 <p>xx1500002187</p>
4	<p>Disconnect the connectors:</p> <ul style="list-style-type: none"> <li>• R2.MP1</li> <li>• R2.ME1</li> </ul> <p> <b>Tip</b></p> <p>Take photos of the connectors and cable position before disconnecting them, to have as a reference when reconnecting.</p>	 <p>xx1500002188</p>

#### Disconnecting the battery cable

	Action	Note
1	<p> <b>DANGER</b></p> <p>Make sure that all supplies for electrical power, hydraulic pressure, and air pressure are turned off.</p>	
2	<p> <b>ELECTROSTATIC DISCHARGE (ESD)</b></p> <p>The unit is sensitive to ESD. Before handling the unit please read the safety information in the section <a href="#">The unit is sensitive to ESD on page 53</a></p>	

Continues on next page



## 4 Repair

### 4.3.2 Replacing the EIB unit

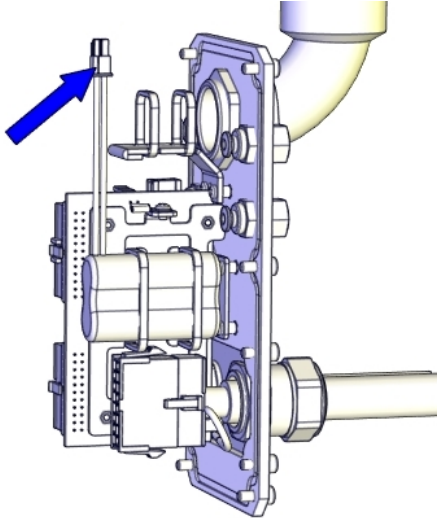
Continued

	Action	Note
3	Disconnect the battery cable.	 <p>xx1500002192</p>

### Removing the EIB unit

	Action	Note
1	 <b>DANGER</b> Make sure that all supplies for electrical power, hydraulic pressure, and air pressure are turned off.	
2	 <b>ELECTROSTATIC DISCHARGE (ESD)</b> The unit is sensitive to ESD. Before handling the unit please read the safety information in the section <a href="#">The unit is sensitive to ESD on page 53</a>	

Continues on next page

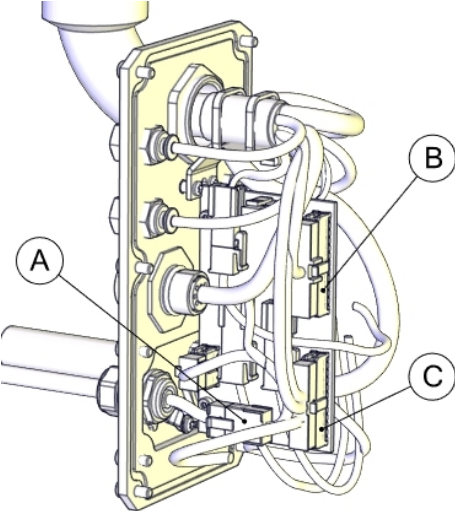
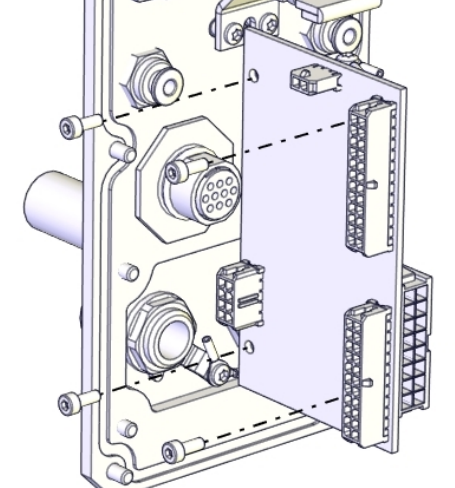
	Action	Note						
3	Disconnect the connectors: <ul style="list-style-type: none"> <li>• R1.EIB</li> <li>• R1.ME4</li> <li>• R1.ME1-3</li> </ul>	 <p>xx1500002195</p> <table border="1" data-bbox="973 869 1430 1003"> <tr> <td>A</td> <td>R1.EIB</td> </tr> <tr> <td>B</td> <td>R1.ME4</td> </tr> <tr> <td>C</td> <td>R1.ME1-3</td> </tr> </table>	A	R1.EIB	B	R1.ME4	C	R1.ME1-3
A	R1.EIB							
B	R1.ME4							
C	R1.ME1-3							
4	Remove the screws.	 <p>xx1500002792</p>						

*Continues on next page*

## 4 Repair

### 4.3.2 Replacing the EIB unit

Continued

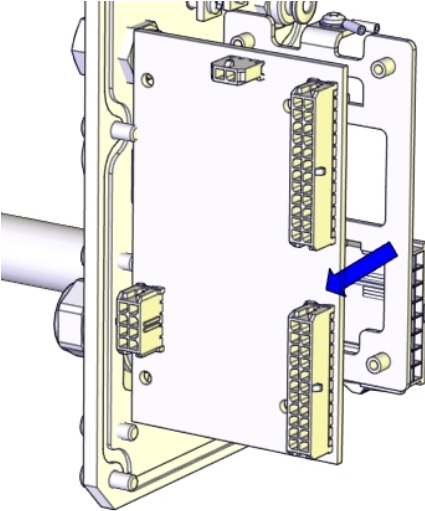
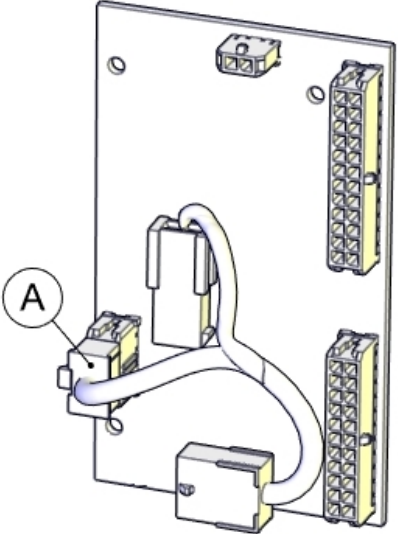

	Action	Note		
5	Remove the EIB unit.	 <p>xx1500002196</p>		
6	Disconnect the connector to remove the EIB connection cable. <ul style="list-style-type: none"><li>• R2.EIB</li></ul>	 <p>xx1500002197</p> <table border="1" data-bbox="943 1525 1401 1570"><tr><td>A</td><td>R2.EIB</td></tr></table>	A	R2.EIB
A	R2.EIB			

Continues on next page

Refitting the EIB unit

Use these procedures to refit the EIB unit.

Refitting the EIB unit

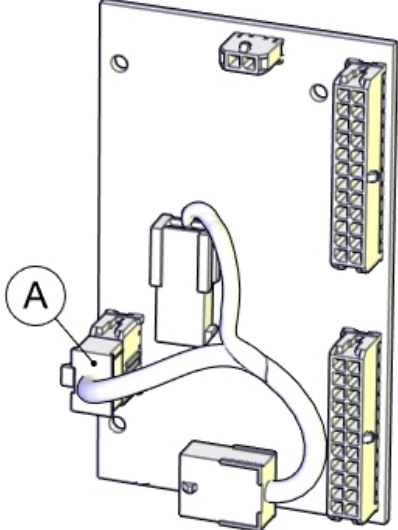
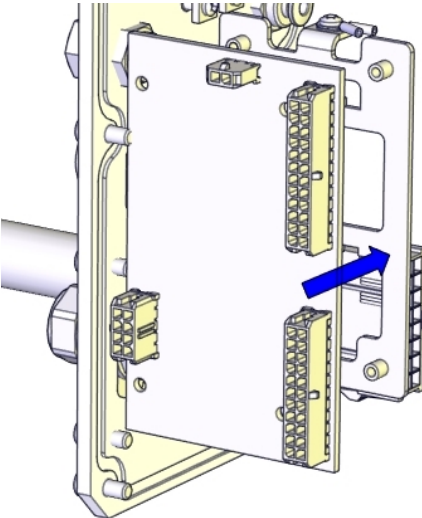
	Action	Note		
1	 <p><b>ELECTROSTATIC DISCHARGE (ESD)</b></p> <p>The unit is sensitive to ESD. Before handling the unit please read the safety information in the section <i>The unit is sensitive to ESD on page 53</i></p>			
2	<p>Reconnect the connector to refit the EIB connection cable.</p> <ul style="list-style-type: none"> <li>R2.EIB</li> </ul>  <p><b>CAUTION</b></p> <p>The EIB connection cable has one connector at one end and two connectors at the other end.</p> <p>Make sure not to mix the connectors. See the labels on the connectors for correct connection.</p>	<p>EIB connection cable: 3HAC056703-001</p>  <p>xx1500002197</p> <table border="1" data-bbox="973 1377 1433 1422"> <tr> <td data-bbox="973 1377 1029 1422">A</td> <td data-bbox="1029 1377 1433 1422">R2.EIB</td> </tr> </table>	A	R2.EIB
A	R2.EIB			
3	<p>Refit the EIB unit.</p>	 <p>xx1500002793</p>		

Continues on next page

## 4 Repair

### 4.3.2 Replacing the EIB unit

Continued

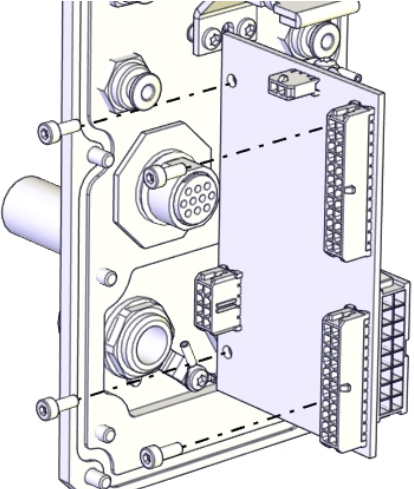
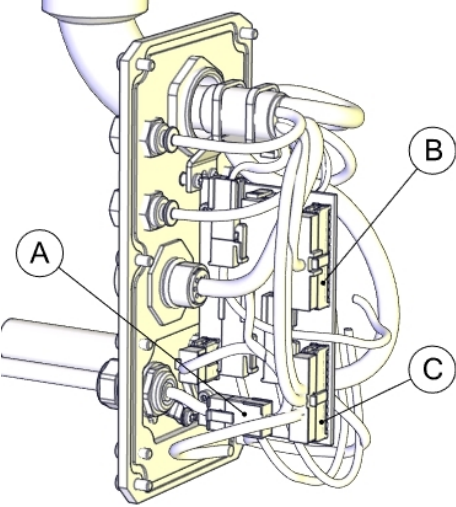
	Action	Note						
4	Secure with screws.	 <p data-bbox="943 808 1050 831">xx1500002792</p> <p data-bbox="943 846 1233 909">Screw: M3x8 (4 pcs) Tightening torque: 0.3 Nm</p>						
5	Reconnect the connectors. <ul style="list-style-type: none"> <li>• R1.EIB</li> <li>• R1.ME4</li> <li>• R1.ME1-3</li> </ul> <p data-bbox="472 1070 671 1122"><b>!</b> CAUTION</p> <p data-bbox="464 1137 933 1243">Make sure not to mix the connectors; otherwise, axes may be damaged. See the labels on the connectors for correct connection.</p>	 <p data-bbox="943 1444 1050 1467">xx1500002195</p> <table border="1" data-bbox="943 1480 1404 1615"> <tbody> <tr> <td data-bbox="943 1480 991 1525">A</td> <td data-bbox="995 1480 1404 1525">R1.EIB</td> </tr> <tr> <td data-bbox="943 1532 991 1576">B</td> <td data-bbox="995 1532 1404 1576">R1.ME4</td> </tr> <tr> <td data-bbox="943 1583 991 1628">C</td> <td data-bbox="995 1583 1404 1628">R1.ME1-3</td> </tr> </tbody> </table>	A	R1.EIB	B	R1.ME4	C	R1.ME1-3
A	R1.EIB							
B	R1.ME4							
C	R1.ME1-3							

#### Connecting the battery cable

	Action	Note
1	 <p data-bbox="555 1778 916 1841"><b>ELECTROSTATIC DISCHARGE (ESD)</b></p> <p data-bbox="464 1861 933 1966">The unit is sensitive to ESD. Before handling the unit please read the safety information in the section <a href="#">The unit is sensitive to ESD on page 53</a></p>	

Continues on next page

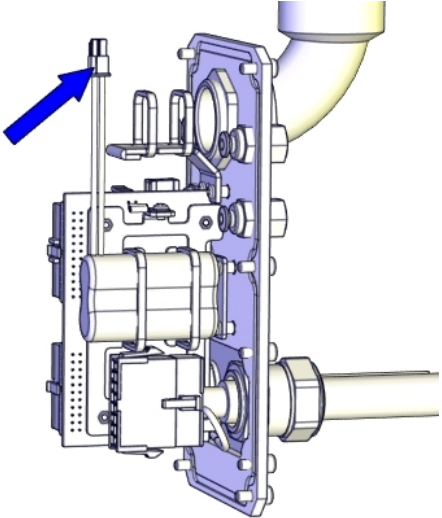

	Action	Note
2	Connect the battery cable.	 <p data-bbox="970 840 1082 857">xx1500002192</p>

Refitting the main cable to the base

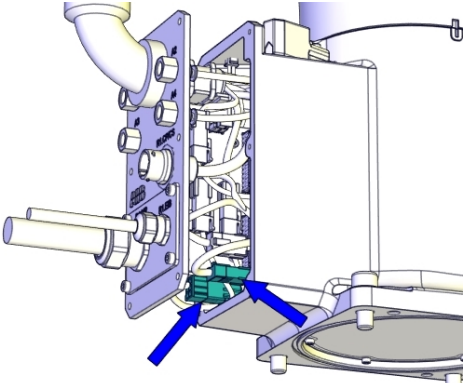
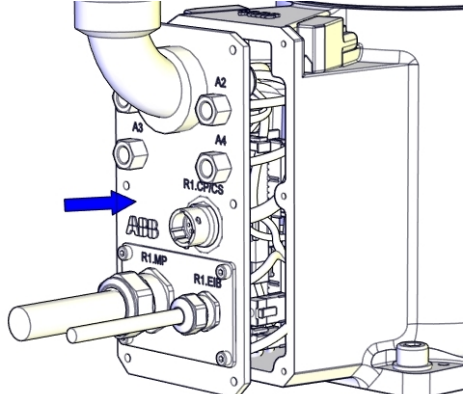
	Action	Note
1	Secure the main cable package with cable ties if needed.	
2	Reconnect the connectors. <ul style="list-style-type: none"> <li>• R2.MP1</li> <li>• R2.ME1</li> </ul>	 <p data-bbox="970 1467 1082 1485">xx1500002188</p>
3	Push the main cable package into place.	 <p data-bbox="970 1926 1082 1944">xx1500002204</p>

Continues on next page

## 4 Repair

### 4.3.2 Replacing the EIB unit

Continued

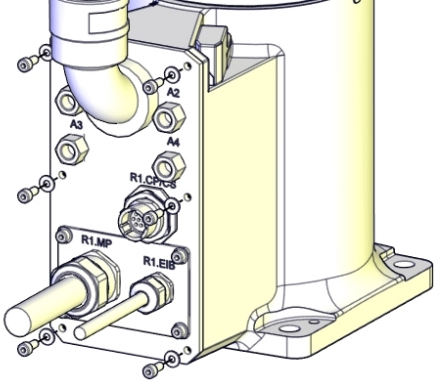
	Action	Note
4	Refit the base cover with screws and washers.	 <p data-bbox="943 703 1050 723">xx1500002186</p> <p data-bbox="943 741 1209 761">Screws: M4x10 (6 pcs)</p> <p data-bbox="943 775 1209 795">Tightening torque: 2 Nm</p>

#### Concluding procedure

	Action	Note
1	Update the revolution counters.	See <a href="#">Updating revolution counters on page 355</a> .
2	 <p data-bbox="560 1039 667 1059"><b>DANGER</b></p> <p data-bbox="464 1099 932 1256">Make sure all safety requirements are met when performing the first test run. These are further detailed in the section "First test run may cause injury or damage" in <i>Safety manual for robot - Manipulator and IRC5 or OmniCore controller</i>.</p>	

### 4.3.3 Replacing the PCB board

#### Location of the PCB board

The PCB board is located as shown in the figure.

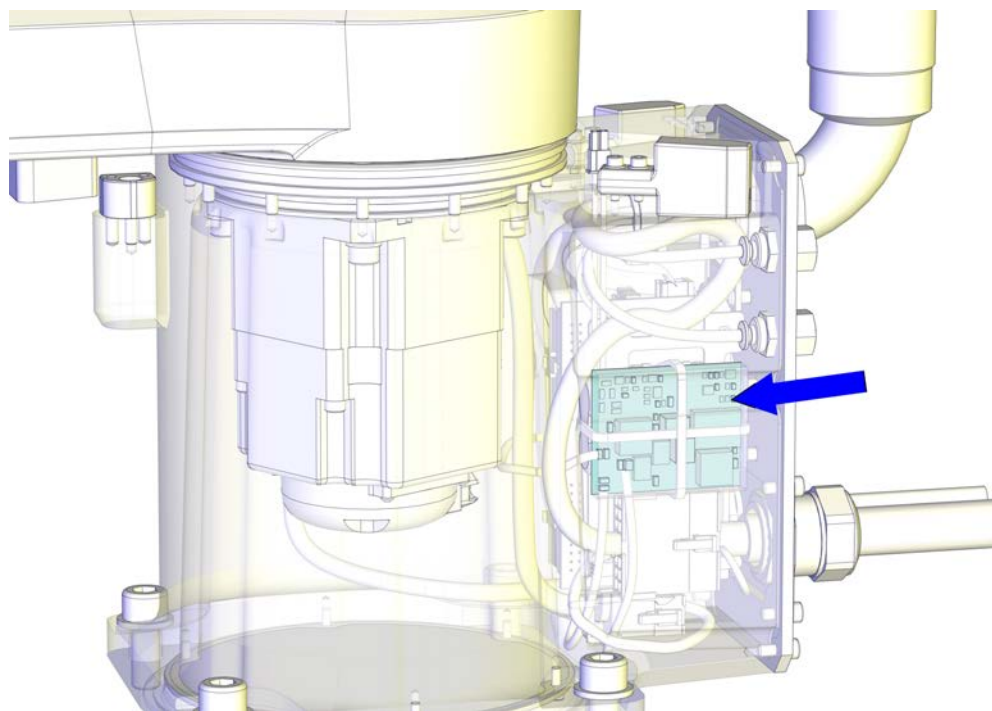

xx1500002179

#### Required spare parts



#### Note

The spare part numbers that are listed in the table can be out of date. See the latest spare parts of the IRB 910SC via myABB Business Portal, [www.abb.com/myABB](http://www.abb.com/myABB).

Spare part	Article number	Note
PCB board	3HAC057687-001	

#### Required tools and equipment

Equipment	Article number	Note
Standard toolkit	-	Content is defined in section <a href="#">Standard toolkit on page 392</a> .

#### Required consumables

Consumable	Article number	Note
Shrink hose	-	Used for protecting the PCB board.
Cable ties	-	

*Continues on next page*

## 4 Repair



### 4.3.3 Replacing the PCB board

*Continued*

#### Removing the PCB board

Use these procedures to remove the PCB board.

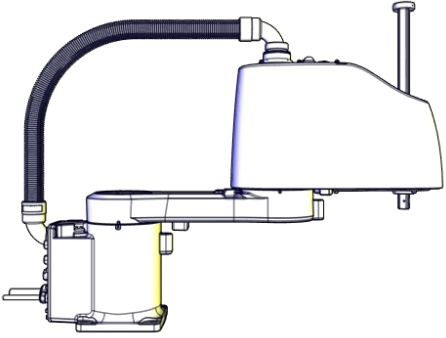

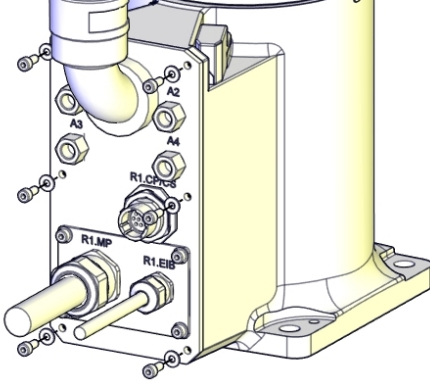

#### Preparations before removing the PCB board

	Action	Note
1	Jog all axes to zero position.	 <p>xx1500002227</p>
2	 <b>DANGER</b> Turn off all: <ul style="list-style-type: none"> <li>• electric power supply</li> <li>• hydraulic pressure supply</li> <li>• air pressure supply</li> </ul> to the robot, before entering the robot working area.	

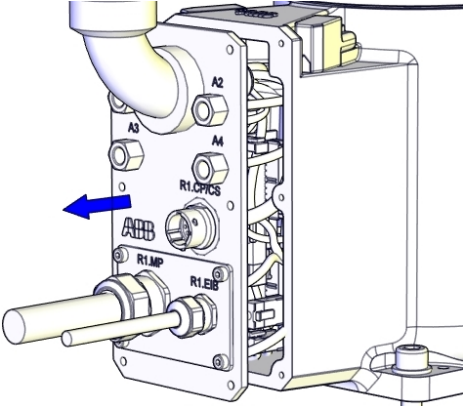

#### Removing the main cable package from the base

	Action	Note
1	 <b>DANGER</b> Make sure that all supplies for electrical power, hydraulic pressure, and air pressure are turned off.	
2	Remove the screws and washers.	 <p>xx1500002186</p>

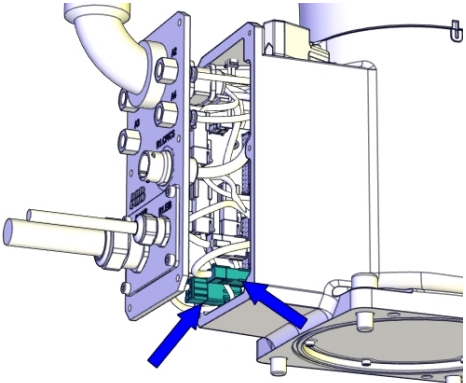
*Continues on next page*

	Action	Note
3	<p>Carefully open the base cover and pull out the cable package.</p> <p> <b>CAUTION</b></p> <p>The cover cannot be removed completely until the connectors are disconnected.</p> <p> <b>CAUTION</b></p> <p>Clean cover from metal residues before opening.</p> <p>Metal residues can cause shortage on the boards which can result in hazardous failures.</p>	 <p>xx1500002187</p>
4	<p>Disconnect the connectors:</p> <ul style="list-style-type: none"> <li>• R2.MP1</li> <li>• R2.ME1</li> </ul> <p> <b>Tip</b></p> <p>Take photos of the connectors and cable position before disconnecting them, to have as a reference when reconnecting.</p>	 <p>xx1500002188</p>

Removing the PCB board

	Action	Note
1	<p> <b>DANGER</b></p> <p>Make sure that all supplies for electrical power, hydraulic pressure, and air pressure are turned off.</p>	
2	<p> <b>ELECTROSTATIC DISCHARGE (ESD)</b></p> <p>The unit is sensitive to ESD. Before handling the unit please read the safety information in the section <a href="#">The unit is sensitive to ESD on page 53</a></p>	

Continues on next page

## 4 Repair

### 4.3.3 Replacing the PCB board

Continued

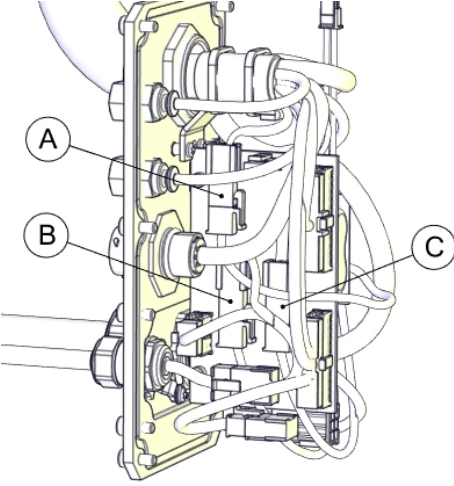
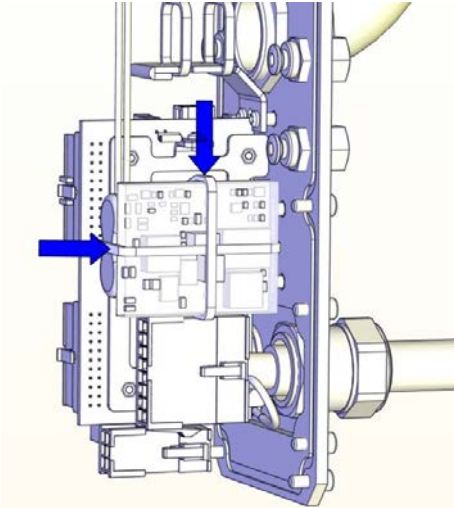
	Action	Note						
3	<p>Disconnect the connectors:</p> <ul style="list-style-type: none"><li>• R1.BK1-2</li><li>• R1.DBP</li><li>• R2.BK1-2</li></ul> <p> <b>Tip</b></p> <p>Take photos of the connectors and cable position before disconnecting them, to have as a reference when reconnecting.</p>	 <p>xx1500002190</p> <table border="1" data-bbox="943 842 1398 976"><tbody><tr><td>A</td><td>R1.BK1-2</td></tr><tr><td>B</td><td>R1.DBP</td></tr><tr><td>C</td><td>R2.BK1-2</td></tr></tbody></table>	A	R1.BK1-2	B	R1.DBP	C	R2.BK1-2
A	R1.BK1-2							
B	R1.DBP							
C	R2.BK1-2							
4	Cut the cable ties.	 <p>xx1500002752</p>						

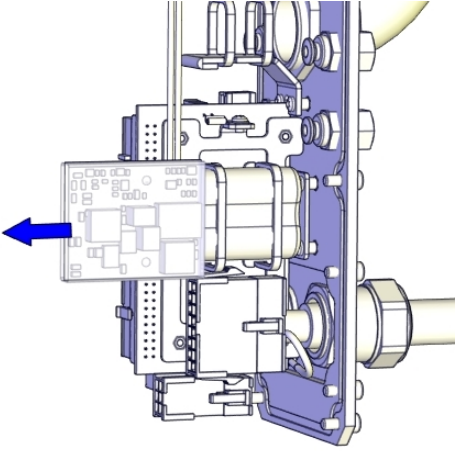

Continues on next page

	Action	Note
5	Remove the PCB board carefully.	 <p data-bbox="973 779 1077 801">xx1500002191</p>

Refitting the PCB board

Use these procedures to refit the PCB board.

Refitting the PCB board

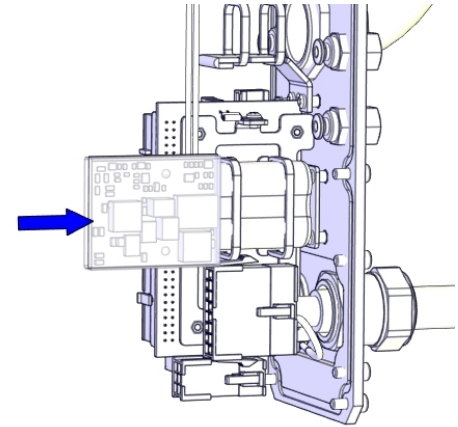

	Action	Note
1	 <p data-bbox="587 1070 946 1126"><b>ELECTROSTATIC DISCHARGE (ESD)</b></p> <p data-bbox="497 1149 962 1256">The unit is sensitive to ESD. Before handling the unit please read the safety information in the section <a href="#">The unit is sensitive to ESD on page 53</a></p>	
2	<p data-bbox="497 1290 727 1317">Refit the PCB board.</p>  <p data-bbox="587 1350 643 1377"><b>Note</b></p> <p data-bbox="497 1406 962 1462">The PCB board is protected by shrink hose. Replace the hose if damaged.</p>	<p data-bbox="973 1290 1300 1317">PCB board: 3HAC057687-001</p>  <p data-bbox="973 1765 1077 1787">xx1500002205</p>

Continues on next page

## 4 Repair

### 4.3.3 Replacing the PCB board

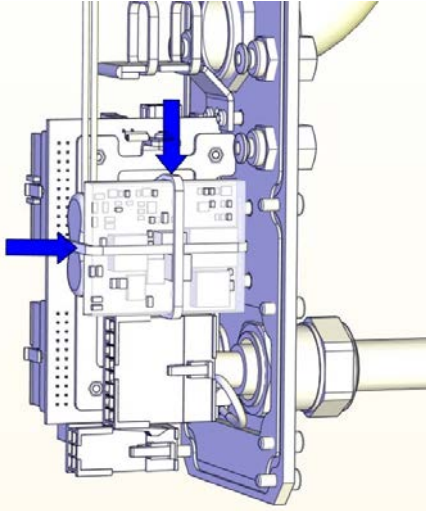
Continued

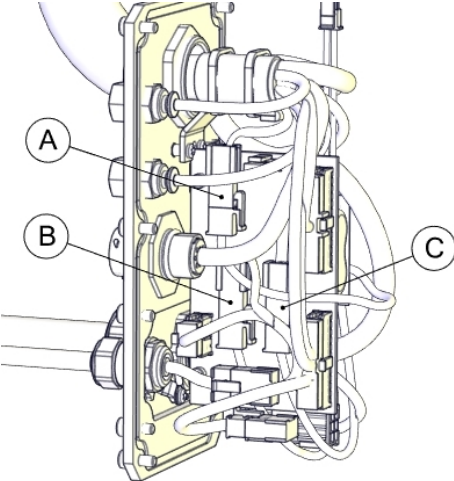
	Action	Note						
3	Secure the PCB board with cable ties. Do not tighten the ties too tight.	 <p data-bbox="943 831 1050 853">xx1500002752</p>						
4	Reconnect the connectors. <ul style="list-style-type: none"> <li>• R1.BK1-2</li> <li>• R1.DBP</li> <li>• R2.BK1-2</li> </ul> <p data-bbox="472 1025 671 1077">  <b>CAUTION</b> </p> <p data-bbox="464 1099 932 1178">           Make sure not to mix the connectors. See the labels on the connectors for correct connection.         </p>	 <p data-bbox="943 1375 1050 1397">xx1500002190</p> <table border="1" data-bbox="943 1413 1404 1552"> <tbody> <tr> <td data-bbox="943 1413 991 1458">A</td> <td data-bbox="995 1413 1404 1458">R1.BK1-2</td> </tr> <tr> <td data-bbox="943 1464 991 1509">B</td> <td data-bbox="995 1464 1404 1509">R1.DBP</td> </tr> <tr> <td data-bbox="943 1516 991 1552">C</td> <td data-bbox="995 1516 1404 1552">R2.BK1-2</td> </tr> </tbody> </table>	A	R1.BK1-2	B	R1.DBP	C	R2.BK1-2
A	R1.BK1-2							
B	R1.DBP							
C	R2.BK1-2							
5	Secure the cables with cable ties if needed.							

#### Refitting the main cable to the base

	Action	Note
1	Secure the main cable package with cable ties if needed.	

Continues on next page

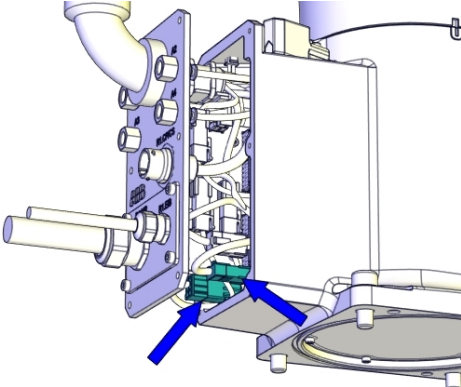
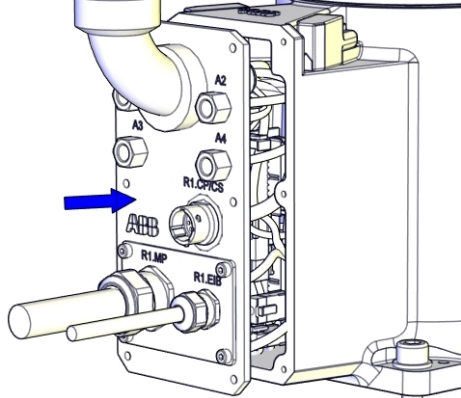
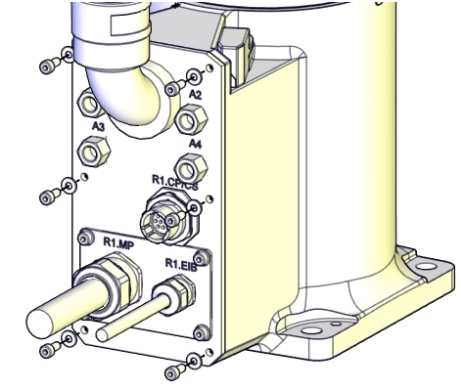

	Action	Note
2	Reconnect the connectors. <ul style="list-style-type: none"> <li>• R2.MP1</li> <li>• R2.ME1</li> </ul>	 <p>xx1500002188</p>
3	Push the main cable package into place.	 <p>xx1500002204</p>
4	Refit the base cover with screws and washers.	 <p>xx1500002186</p> <p>Screws: M4x10 (6 pcs) Tightening torque: 2 Nm</p>

#### Concluding procedure

	Action	Note
1	Update the revolution counters.	See <a href="#">Updating revolution counters on page 355</a> .

*Continues on next page*

## 4 Repair

---

### 4.3.3 Replacing the PCB board

*Continued*

	Action	Note
2	 <b>DANGER</b> Make sure all safety requirements are met when performing the first test run. These are further detailed in the section "First test run may cause injury or damage" in <i>Safety manual for robot - Manipulator and IRC5 or OmniCore controller</i> .	

### 4.3.4 Replacing the EIB mounting plate

#### Location of the EIB mounting plate

The EIB mounting plate is located as shown in the figure.

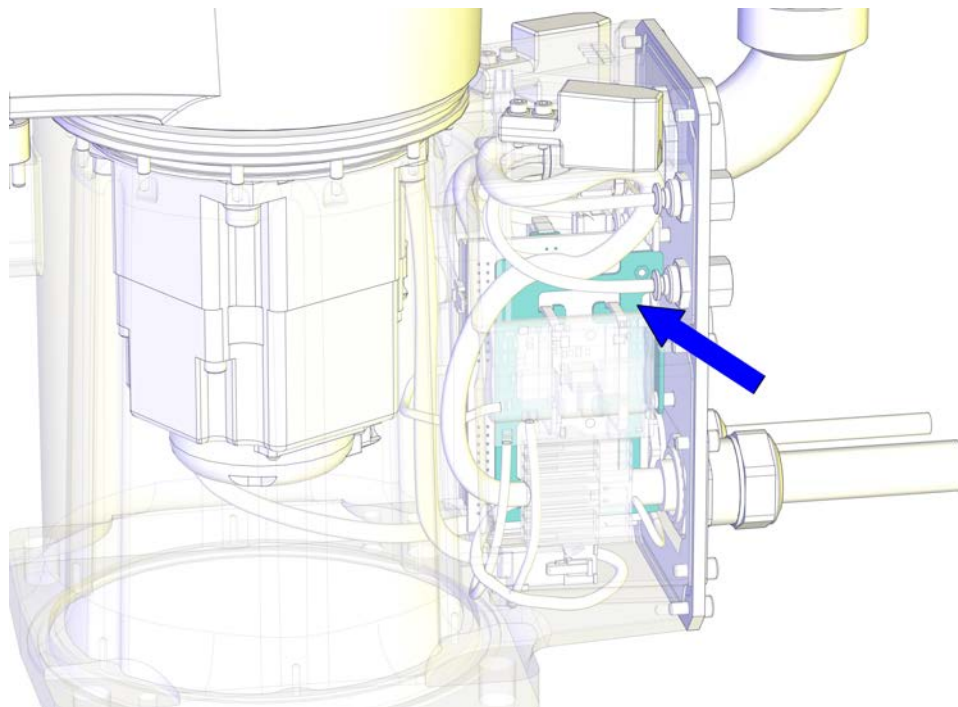

xx1500002517

#### Required spare parts



#### Note

The spare part numbers that are listed in the table can be out of date. See the latest spare parts of the IRB 910SC via myABB Business Portal, [www.abb.com/myABB](http://www.abb.com/myABB).

Spare part	Article number	Note
EIB mounting plate	3HAC055165-001	
EIB connection cable	3HAC056703-001	Replace if damaged.

#### Required tools and equipment

Equipment	Article number	Note
Standard toolkit	-	Content is defined in section <a href="#">Standard toolkit on page 392</a> .

#### Required consumables

Consumable	Article number	Note
Cable ties	-	

*Continues on next page*

## 4 Repair



### 4.3.4 Replacing the EIB mounting plate

*Continued*

#### Removing the EIB mounting plate

Use these procedures to remove the EIB mounting plate.

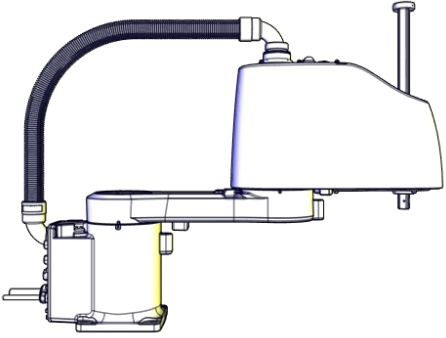
#### Preparations before removing the EIB mounting plate



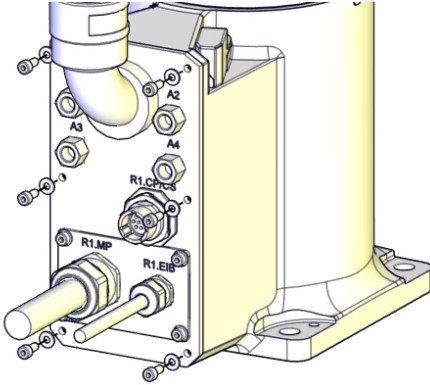

	Action	Note
1	Jog all axes to zero position.	 <p>xx1500002227</p>
2	 <b>DANGER</b> Turn off all: <ul style="list-style-type: none"> <li>• electric power supply</li> <li>• hydraulic pressure supply</li> <li>• air pressure supply</li> </ul> to the robot, before entering the robot working area.	

#### Removing the main cable package from the base

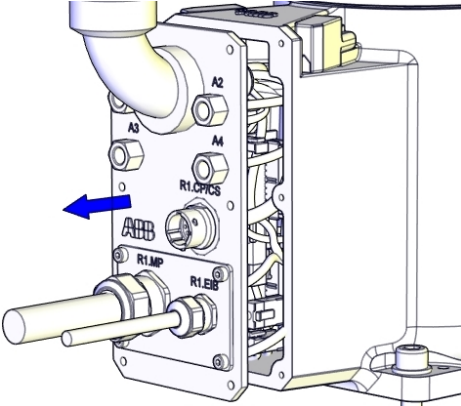

	Action	Note
1	 <b>DANGER</b> Make sure that all supplies for electrical power, hydraulic pressure, and air pressure are turned off.	
2	Remove the screws and washers.	 <p>xx1500002186</p>

*Continues on next page*

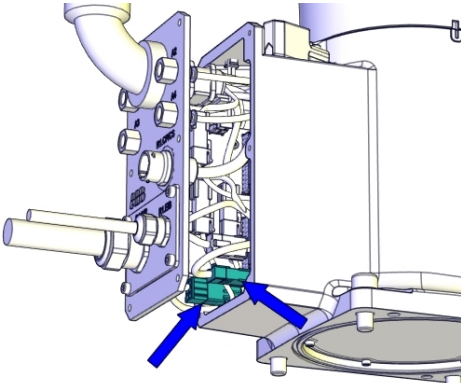
4.3.4 Replacing the EIB mounting plate  
Continued

	Action	Note
3	<p>Carefully open the base cover and pull out the cable package.</p> <p> <b>CAUTION</b></p> <p>The cover cannot be removed completely until the connectors are disconnected.</p> <p> <b>CAUTION</b></p> <p>Clean cover from metal residues before opening.</p> <p>Metal residues can cause shortage on the boards which can result in hazardous failures.</p>	 <p>xx1500002187</p>
4	<p>Disconnect the connectors:</p> <ul style="list-style-type: none"> <li>• R2.MP1</li> <li>• R2.ME1</li> </ul> <p> <b>Tip</b></p> <p>Take photos of the connectors and cable position before disconnecting them, to have as a reference when reconnecting.</p>	 <p>xx1500002188</p>

Removing the PCB board

	Action	Note
1	<p> <b>DANGER</b></p> <p>Make sure that all supplies for electrical power, hydraulic pressure, and air pressure are turned off.</p>	
2	<p> <b>ELECTROSTATIC DISCHARGE (ESD)</b></p> <p>The unit is sensitive to ESD. Before handling the unit please read the safety information in the section <a href="#">The unit is sensitive to ESD on page 53</a></p>	

Continues on next page

## 4 Repair

### 4.3.4 Replacing the EIB mounting plate

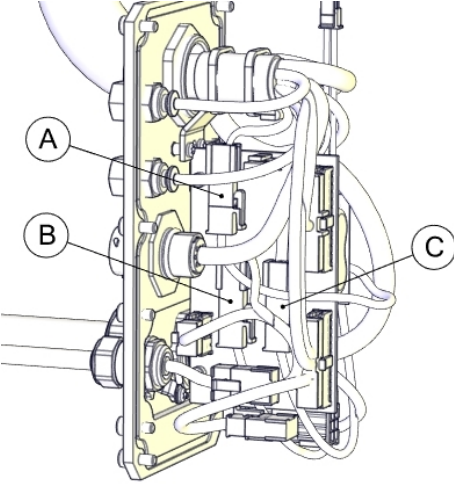
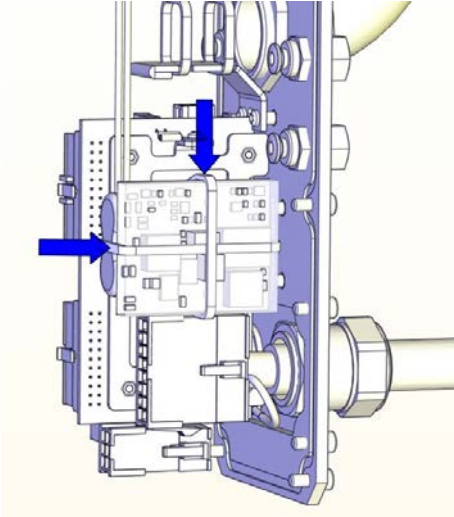

Continued

	Action	Note						
3	<p>Disconnect the connectors:</p> <ul style="list-style-type: none"><li>• R1.BK1-2</li><li>• R1.DBP</li><li>• R2.BK1-2</li></ul> <p> <b>Tip</b></p> <p>Take photos of the connectors and cable position before disconnecting them, to have as a reference when reconnecting.</p>	 <p>xx1500002190</p> <table border="1" data-bbox="943 842 1398 976"><tr><td>A</td><td>R1.BK1-2</td></tr><tr><td>B</td><td>R1.DBP</td></tr><tr><td>C</td><td>R2.BK1-2</td></tr></table>	A	R1.BK1-2	B	R1.DBP	C	R2.BK1-2
A	R1.BK1-2							
B	R1.DBP							
C	R2.BK1-2							
4	Cut the cable ties.	 <p>xx1500002752</p>						

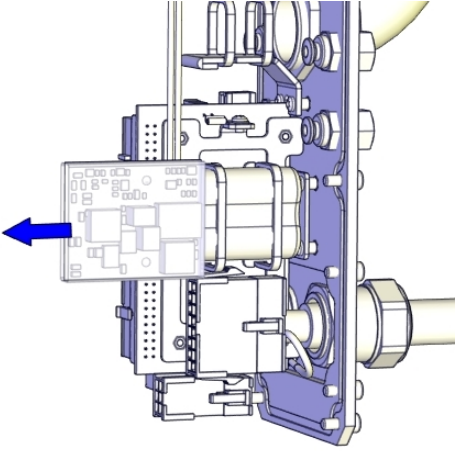
Continues on next page

	Action	Note
5	Remove the PCB board carefully.	 <p data-bbox="973 772 1077 795">xx1500002191</p>

Disconnecting the battery cable

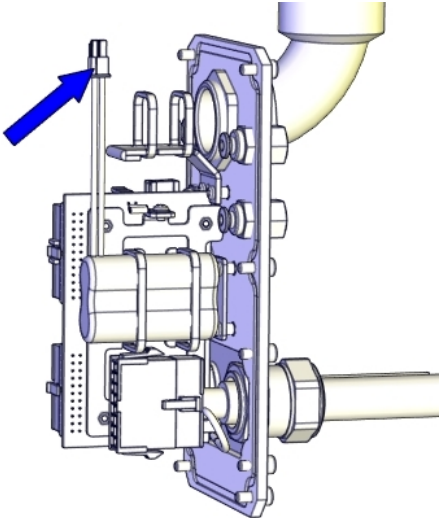
	Action	Note
1	 <p data-bbox="587 974 694 1003"><b>DANGER</b></p> <p data-bbox="497 1034 962 1115">Make sure that all supplies for electrical power, hydraulic pressure, and air pressure are turned off.</p>	
2	 <p data-bbox="587 1171 946 1227"><b>ELECTROSTATIC DISCHARGE (ESD)</b></p> <p data-bbox="497 1245 962 1355">The unit is sensitive to ESD. Before handling the unit please read the safety information in the section <a href="#">The unit is sensitive to ESD on page 53</a></p>	
3	Disconnect the battery cable.	 <p data-bbox="973 1915 1077 1937">xx1500002192</p>





Continues on next page

## 4 Repair

### 4.3.4 Replacing the EIB mounting plate

*Continued*

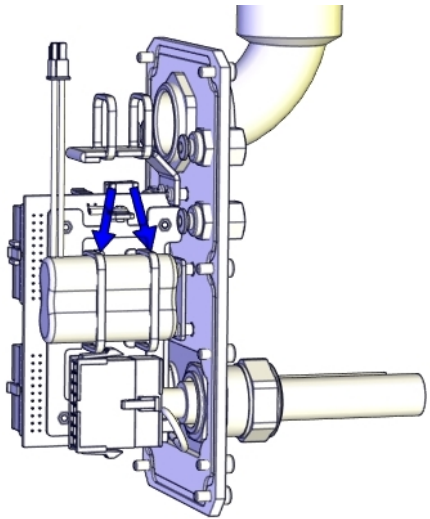

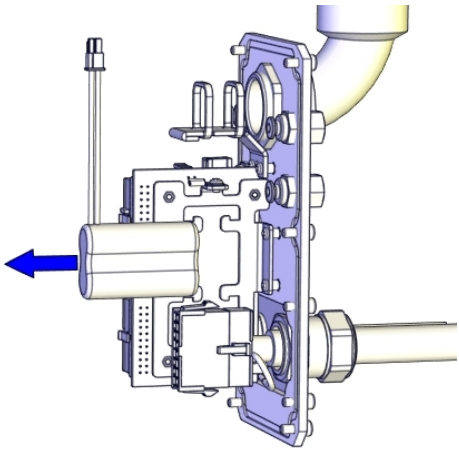
#### Removing the battery pack

	Action	Note
1	 <b>DANGER</b> Make sure that all supplies for electrical power, hydraulic pressure, and air pressure are turned off.	
2	 <b>ELECTROSTATIC DISCHARGE (ESD)</b> The unit is sensitive to ESD. Before handling the unit please read the safety information in the section <a href="#">The unit is sensitive to ESD on page 53</a>	
3	Cut the cable ties.	 xx1500002193
4	Remove the battery.  <b>Note</b> Battery includes protection circuits. Only replace with a specified spare part or with an ABB- approved equivalent.	 xx1500002194

*Continues on next page*

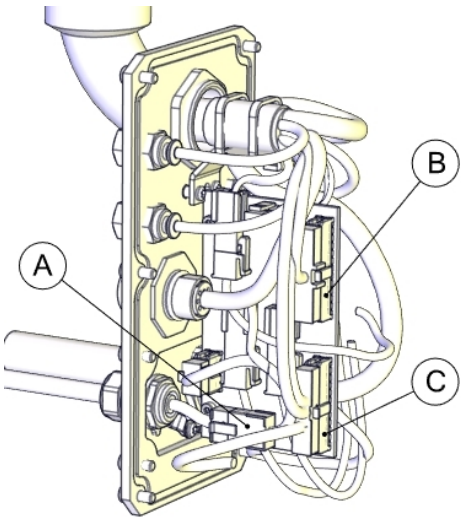

Removing the EIB unit

	Action	Note						
1	 <p><b>DANGER</b></p> <p>Make sure that all supplies for electrical power, hydraulic pressure, and air pressure are turned off.</p>							
2	 <p><b>ELECTROSTATIC DISCHARGE (ESD)</b></p> <p>The unit is sensitive to ESD. Before handling the unit please read the safety information in the section <i>The unit is sensitive to ESD on page 53</i></p>							
3	<p>Disconnect the connectors:</p> <ul style="list-style-type: none"> <li>• R1.EIB</li> <li>• R1.ME4</li> <li>• R1.ME1-3</li> </ul>	 <p>xx1500002195</p> <table border="1" data-bbox="970 1361 1433 1500"> <tbody> <tr> <td>A</td> <td>R1.EIB</td> </tr> <tr> <td>B</td> <td>R1.ME4</td> </tr> <tr> <td>C</td> <td>R1.ME1-3</td> </tr> </tbody> </table>	A	R1.EIB	B	R1.ME4	C	R1.ME1-3
A	R1.EIB							
B	R1.ME4							
C	R1.ME1-3							

Continues on next page

## 4 Repair

### 4.3.4 Replacing the EIB mounting plate

*Continued*

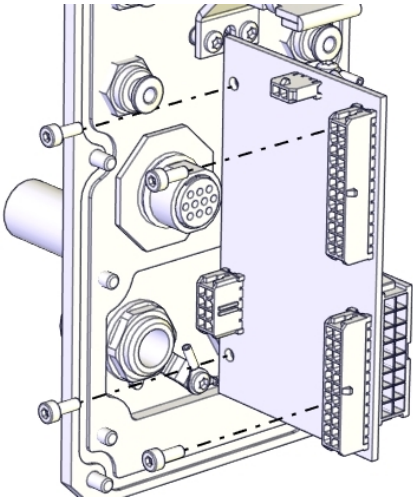
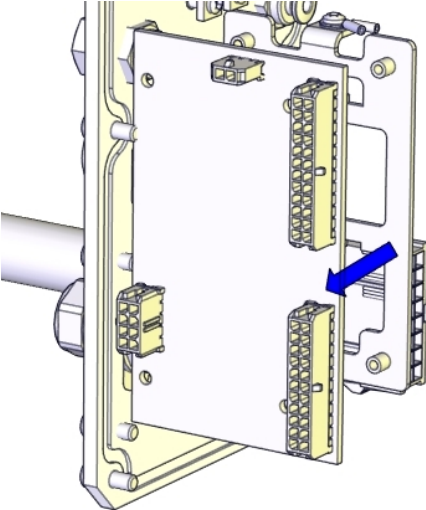
	Action	Note
4	Remove the screws.	 <p>xx1500002792</p>
5	Remove the EIB unit.	 <p>xx1500002196</p>

*Continues on next page*

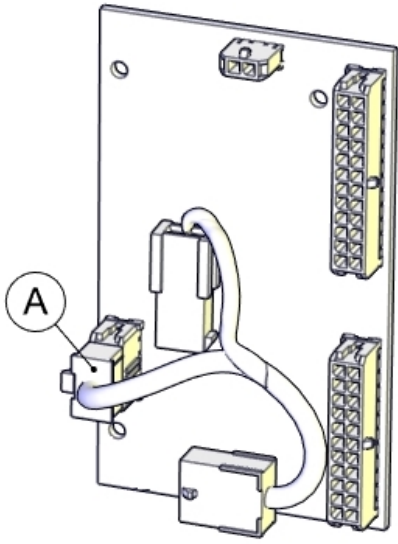
	Action	Note		
6	Disconnect the connector to remove the EIB connection cable. <ul style="list-style-type: none"> <li>• R2.EIB</li> </ul>	 <p>xx1500002197</p> <table border="1" data-bbox="973 952 1433 996"> <tr> <td>A</td> <td>R2.EIB</td> </tr> </table>	A	R2.EIB
A	R2.EIB			

Removing the EIB mounting plate

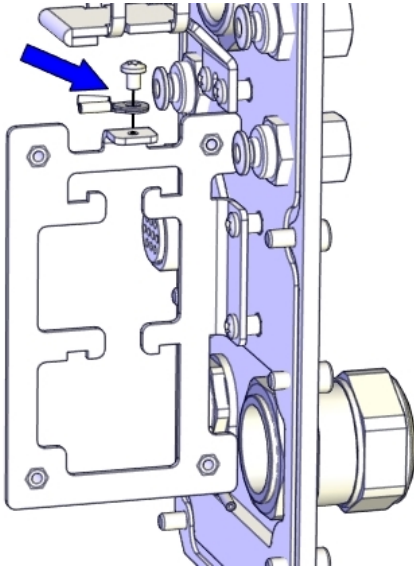
	Action	Note
1	 <b>DANGER</b> Make sure that all supplies for electrical power, hydraulic pressure, and air pressure are turned off.	
2	Disconnect the earth cable by removing the screw.	 <p>xx1500002794</p>

Continues on next page

## 4 Repair

### 4.3.4 Replacing the EIB mounting plate

*Continued*

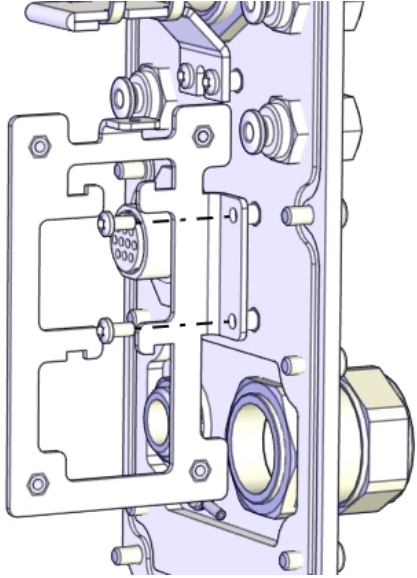
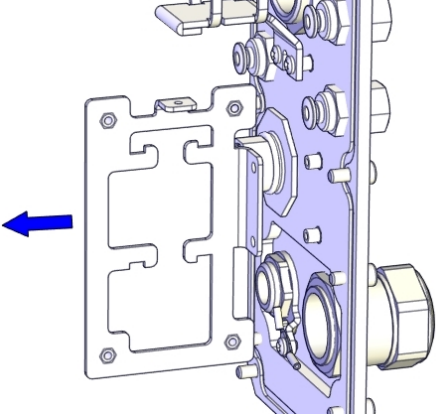
	Action	Note
3	Remove the screws.	 <p>xx1500002795</p>
4	Remove the EIB mounting plate.	 <p>xx1500002198</p>

*Continues on next page*

**Refitting the EIB mounting plate**

Use these procedures to refit the EIB mounting plate.

Refitting the EIB mounting plate

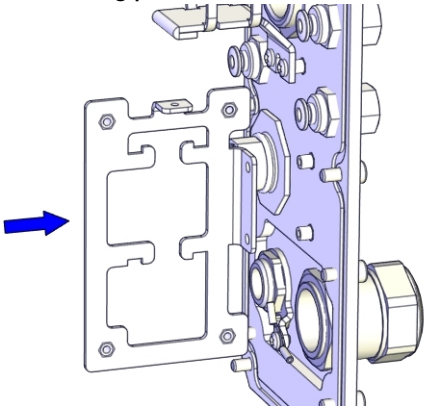
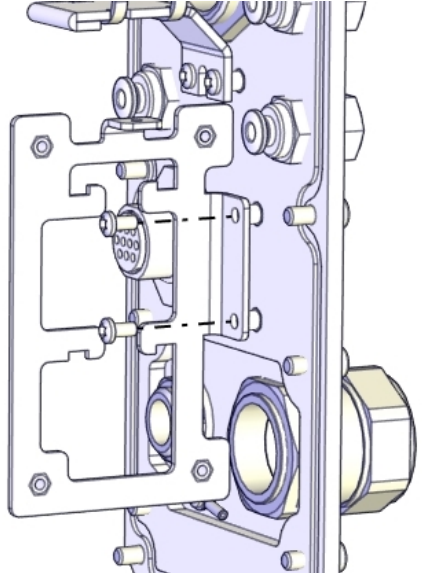
	Action	Note
1	Refit the EIB mounting plate.	<p>EIB mounting plate: 3HAC055165-001</p>  <p>xx1500002796</p>
2	Secure with screws.	 <p>xx1500002795</p> <p>Screw: M3x6 (2 pcs) Tightening torque: 1.5 Nm</p>

*Continues on next page*

## 4 Repair

### 4.3.4 Replacing the EIB mounting plate

Continued

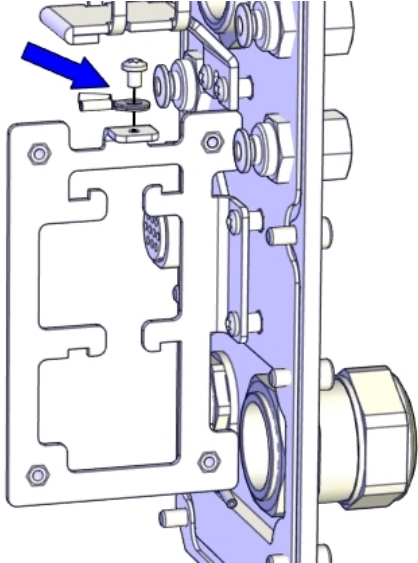
	Action	Note
3	Connect the earth cable with the screw.	 <p data-bbox="936 878 1050 898">xx1500002794</p> <p data-bbox="936 913 1166 943">Screw: M3x4 (1 pcs)</p> <p data-bbox="936 949 1230 978">Tightening torque: 0.3 Nm</p>

### Refitting the EIB unit

	Action	Note
1	 <b>ELECTROSTATIC DISCHARGE (ESD)</b> The unit is sensitive to ESD. Before handling the unit please read the safety information in the section <a href="#">The unit is sensitive to ESD on page 53</a>	

Continues on next page

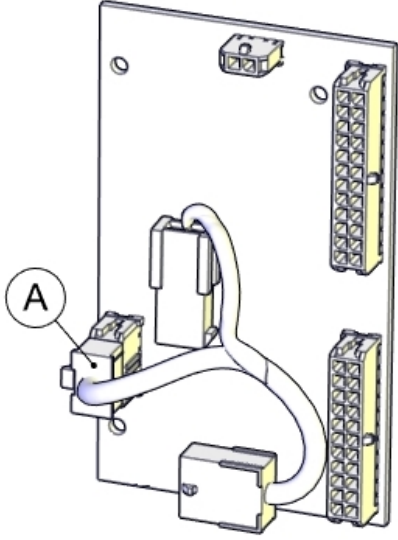
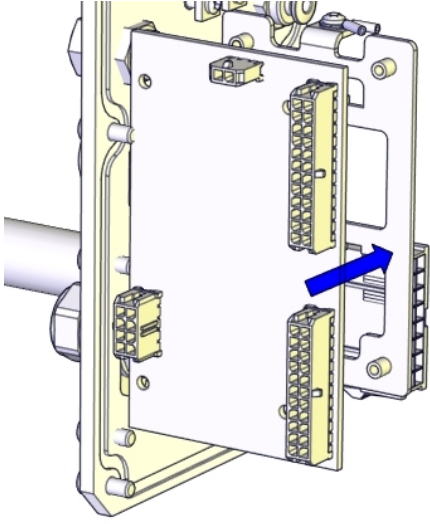

	Action	Note		
2	<p>Reconnect the connector to refit the EIB connection cable.</p> <ul style="list-style-type: none"> <li>• R2.EIB</li> </ul> <p> <b>CAUTION</b></p> <p>The EIB connection cable has one connector at one end and two connectors at the other end.</p> <p>Make sure not to mix the connectors. See the labels on the connectors for correct connection.</p>	<p>EIB connection cable: 3HAC056703-001</p>  <p>xx1500002197</p> <table border="1" data-bbox="971 983 1436 1032"> <tr> <td data-bbox="971 983 1027 1032">A</td> <td data-bbox="1027 983 1436 1032">R2.EIB</td> </tr> </table>	A	R2.EIB
A	R2.EIB			
3	<p>Refit the EIB unit.</p>	 <p>xx1500002793</p>		

Continues on next page

## 4 Repair

### 4.3.4 Replacing the EIB mounting plate

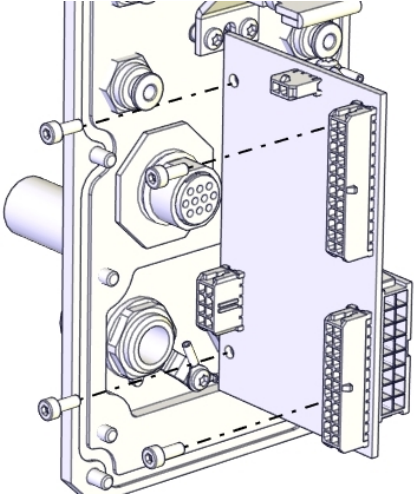
Continued

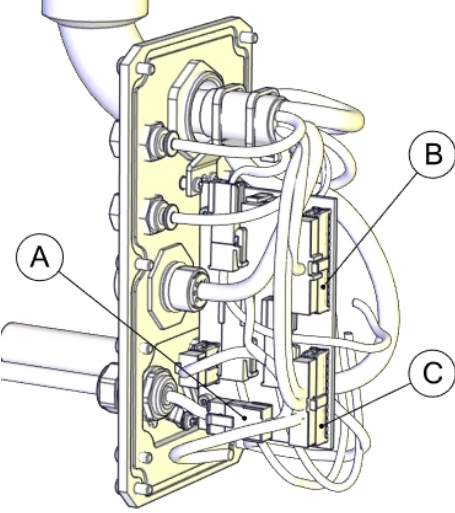
	Action	Note						
4	Secure with screws.	 <p data-bbox="943 808 1050 831">xx1500002792</p> <p data-bbox="943 846 1233 909">Screw: M3x8 (4 pcs) Tightening torque: 0.3 Nm</p>						
5	Reconnect the connectors. <ul style="list-style-type: none"> <li>• R1.EIB</li> <li>• R1.ME4</li> <li>• R1.ME1-3</li> </ul>  <p data-bbox="555 1081 671 1111"><b>CAUTION</b></p> <p data-bbox="464 1137 933 1245">Make sure not to mix the connectors; otherwise, axes may be damaged. See the labels on the connectors for correct connection.</p>	 <p data-bbox="943 1442 1050 1464">xx1500002195</p> <table border="1" data-bbox="943 1480 1404 1619"> <tbody> <tr> <td data-bbox="943 1480 991 1525">A</td> <td data-bbox="995 1480 1404 1525">R1.EIB</td> </tr> <tr> <td data-bbox="943 1532 991 1576">B</td> <td data-bbox="995 1532 1404 1576">R1.ME4</td> </tr> <tr> <td data-bbox="943 1583 991 1628">C</td> <td data-bbox="995 1583 1404 1628">R1.ME1-3</td> </tr> </tbody> </table>	A	R1.EIB	B	R1.ME4	C	R1.ME1-3
A	R1.EIB							
B	R1.ME4							
C	R1.ME1-3							

### Refitting the battery pack

	Action	Note
1	 <p data-bbox="555 1783 916 1843"><b>ELECTROSTATIC DISCHARGE (ESD)</b></p> <p data-bbox="464 1861 933 1968">The unit is sensitive to ESD. Before handling the unit please read the safety information in the section <a href="#">The unit is sensitive to ESD on page 53</a></p>	

Continues on next page

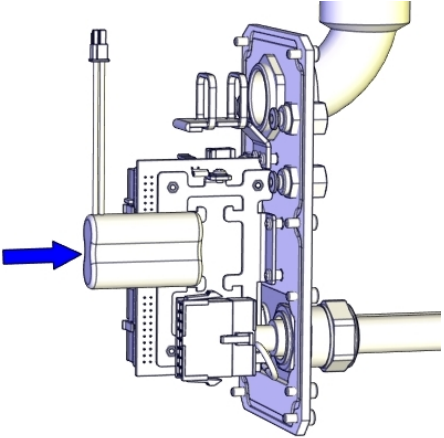
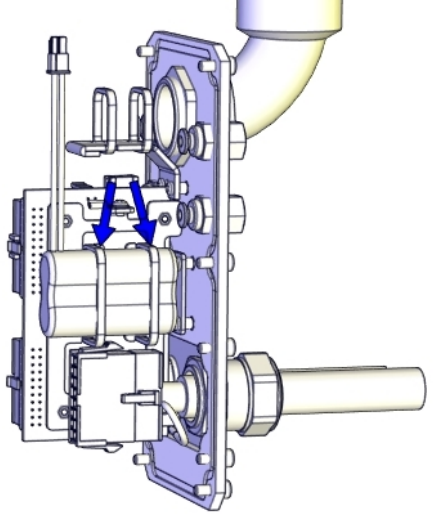

	Action	Note
2	<p>Fit the battery.</p> <p> <b>Note</b></p> <p>Battery includes protection circuits. Only replace with a specified spare part or with an ABB- approved equivalent.</p>	 <p>xx1500002206</p>
3	<p>Secure the battery with cable ties.</p>	 <p>xx1500002193</p>

Connecting the battery cable

	Action	Note
1	<p> <b>ELECTROSTATIC DISCHARGE (ESD)</b></p> <p>The unit is sensitive to ESD. Before handling the unit please read the safety information in the section <i>The unit is sensitive to ESD on page 53</i></p>	

Continues on next page



## 4 Repair

### 4.3.4 Replacing the EIB mounting plate

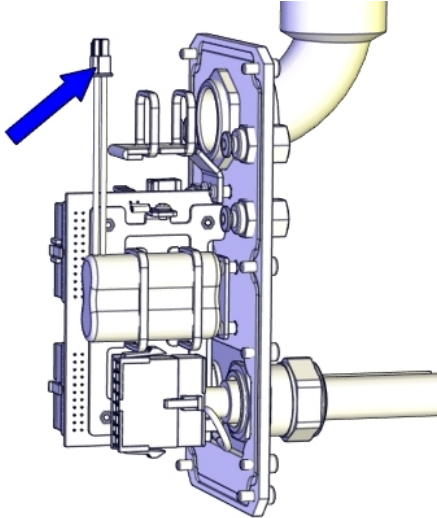

Continued

	Action	Note
2	Connect the battery cable.	 <p data-bbox="943 840 1050 857">xx1500002192</p>

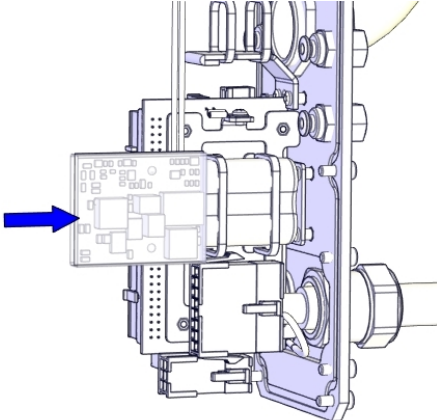
### Refitting the PCB board

	Action	Note
1	 <p data-bbox="555 1025 916 1086"><b>ELECTROSTATIC DISCHARGE (ESD)</b></p> <p data-bbox="464 1106 932 1211">The unit is sensitive to ESD. Before handling the unit please read the safety information in the section <i>The unit is sensitive to ESD on page 53</i></p>	
2	<p data-bbox="464 1249 699 1279">Refit the PCB board.</p>  <p data-bbox="555 1308 616 1337"><b>Note</b></p> <p data-bbox="464 1361 932 1422">The PCB board is protected by shrink hose. Replace the hose if damaged.</p>	<p data-bbox="943 1249 1270 1279">PCB board: 3HAC057687-001</p>  <p data-bbox="943 1715 1050 1733">xx1500002205</p>

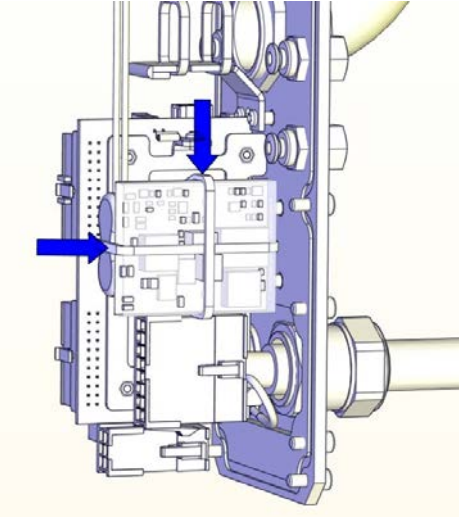
Continues on next page

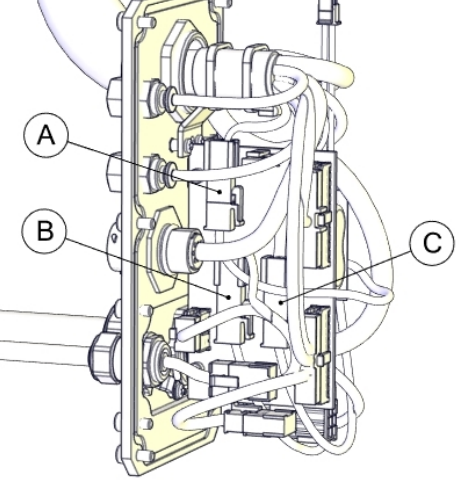
	Action	Note						
3	Secure the PCB board with cable ties. Do not tighten the ties too tight.	 <p>xx1500002752</p>						
4	Reconnect the connectors. <ul style="list-style-type: none"> <li>• R1.BK1-2</li> <li>• R1.DBP</li> <li>• R2.BK1-2</li> </ul>  <b>CAUTION</b> Make sure not to mix the connectors. See the labels on the connectors for correct connection.	 <p>xx1500002190</p> <table border="1" data-bbox="975 1413 1436 1552"> <tbody> <tr> <td>A</td> <td>R1.BK1-2</td> </tr> <tr> <td>B</td> <td>R1.DBP</td> </tr> <tr> <td>C</td> <td>R2.BK1-2</td> </tr> </tbody> </table>	A	R1.BK1-2	B	R1.DBP	C	R2.BK1-2
A	R1.BK1-2							
B	R1.DBP							
C	R2.BK1-2							
5	Secure the cables with cable ties if needed.							

Refitting the main cable to the base

	Action	Note
1	Secure the main cable package with cable ties if needed.	

## 4 Repair

### 4.3.4 Replacing the EIB mounting plate

Continued

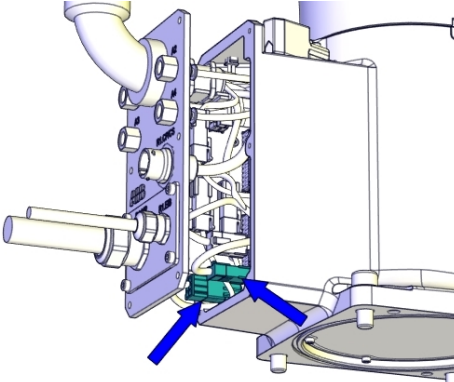
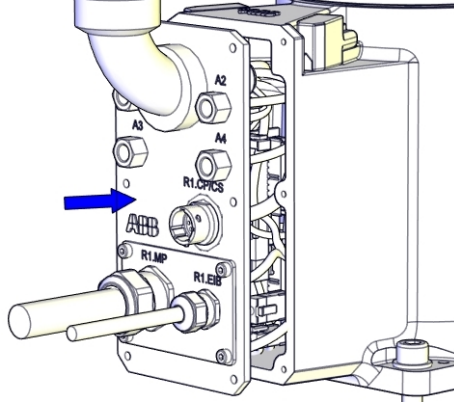
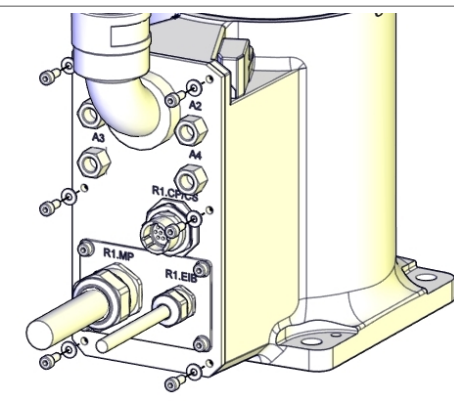
	Action	Note
2	Reconnect the connectors. <ul style="list-style-type: none"> <li>• R2.MP1</li> <li>• R2.ME1</li> </ul>	 <p>xx1500002188</p>
3	Push the main cable package into place.	 <p>xx1500002204</p>
4	Refit the base cover with screws and washers.	 <p>xx1500002186</p> <p>Screws: M4x10 (6 pcs) Tightening torque: 2 Nm</p>

Concluding procedure

	Action	Note
1	Update the revolution counters.	See <a href="#">Updating revolution counters on page 355</a> .

Continues on next page

	Action	Note
2	 <b>DANGER</b> Make sure all safety requirements are met when performing the first test run. These are further detailed in the section "First test run may cause injury or damage" in <i>Safety manual for robot - Manipulator and IRC5 or OmniCore controller</i> .	

## 4 Repair

### 4.3.5 Replacing the floor cables

### 4.3.5 Replacing the floor cables

#### Location of the floor cables

The floor cables are located as shown in the figure.

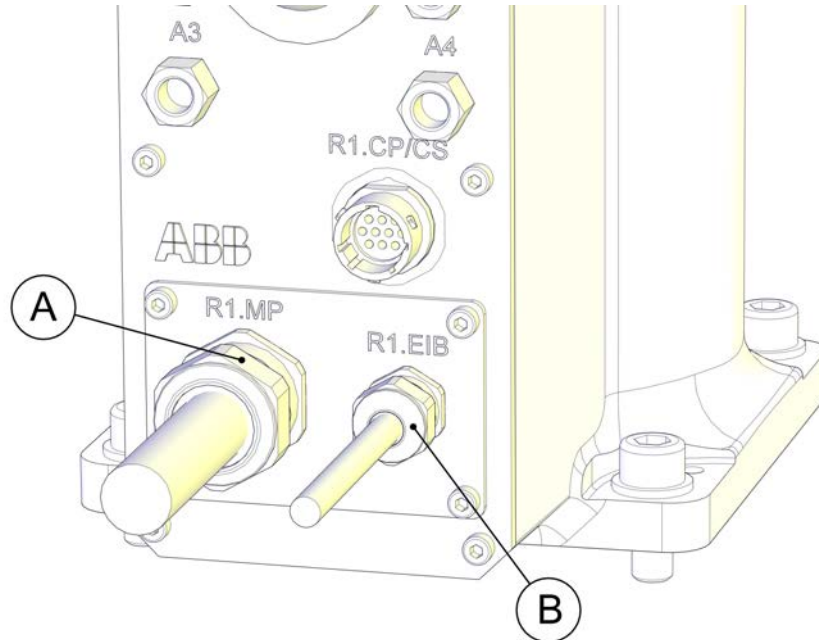

xx1500002181

A	Power floor cable
B	Signal floor cable

#### Required spare parts



#### Note

The spare part numbers that are listed in the table can be out of date. See the latest spare parts of the IRB 910SC via myABB Business Portal, [www.abb.com/myABB](http://www.abb.com/myABB).

Spare part	Article number	Note
Power floor cable, 3 m	3HAC057784-001	
Power floor cable, 7 m	3HAC057785-001	
Power floor cable, 15 m	3HAC057786-001	
Signal floor cable, 3 m	3HAC057787-001	
Signal floor cable, 7 m	3HAC057788-001	
Signal floor cable, 15 m	3HAC057789-001	

Continues on next page

## Required tools and equipment

Equipment	Article number	Note
Standard toolkit	-	Content is defined in section <a href="#">Standard toolkit on page 392</a> .



## Required consumables

Consumable	Article number	Note
Cable ties	-	

## Removing the floor cables

Use these procedures to remove the floor cables.

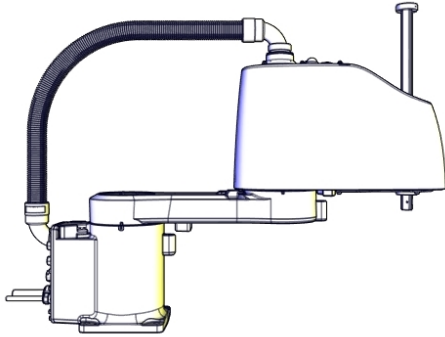
## Preparations before removing the floor cables

	Action	Note
1	Jog all axes to zero position.	 xx1500002227
2	 <b>DANGER</b> Turn off all: <ul style="list-style-type: none"> <li>• electric power supply</li> <li>• hydraulic pressure supply</li> <li>• air pressure supply</li> </ul> to the robot, before entering the robot working area.	

## Removing the floor cables

	Action	Note
1	 <b>DANGER</b> Make sure that all supplies for electrical power, hydraulic pressure, and air pressure are turned off.	

Continues on next page

## 4 Repair

### 4.3.5 Replacing the floor cables

Continued

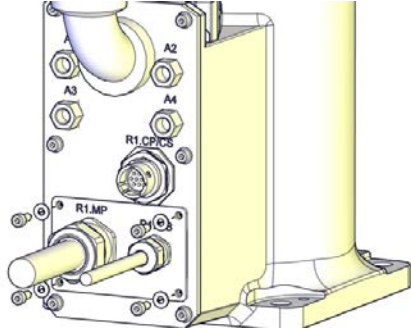
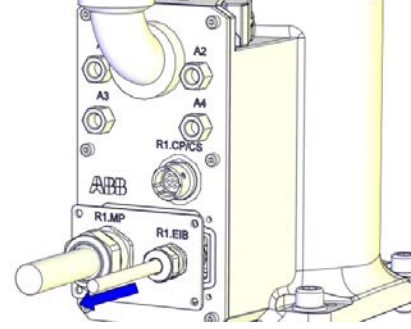
	Action	Note
2	Remove the screws and washers.	 <p>xx1500003003</p>
3	Pull out the floor cables.	 <p>xx1500003004</p>

#### Disconnecting the floor cable connectors

	Action	Note
1	 <p><b>DANGER</b></p> <p>Make sure that all supplies for electrical power, hydraulic pressure, and air pressure are turned off.</p>	

Continues on next page

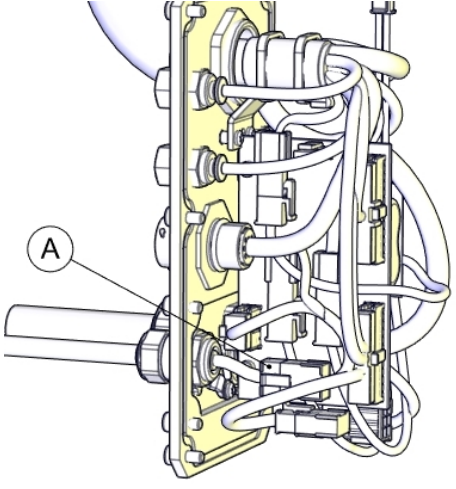
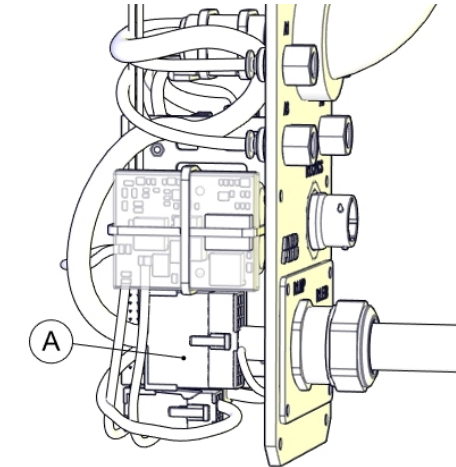

	Action	Note				
2	Disconnect the connectors. <ul style="list-style-type: none"> <li>• R1.EIB</li> <li>• R1.MP</li> </ul>	 <p>xx1500002202</p> <table border="1" data-bbox="970 853 1428 898"> <tr> <td>A</td> <td>R1.EIB</td> </tr> </table>  <p>xx1500002203</p> <table border="1" data-bbox="970 1435 1428 1480"> <tr> <td>A</td> <td>R1.MP</td> </tr> </table>	A	R1.EIB	A	R1.MP
A	R1.EIB					
A	R1.MP					

Separating the signal floor cable

	Action	Note
1	 <p><b>DANGER</b></p> <p>Make sure that all supplies for electrical power, hydraulic pressure, and air pressure are turned off.</p>	

Continues on next page

## 4 Repair

### 4.3.5 Replacing the floor cables

*Continued*

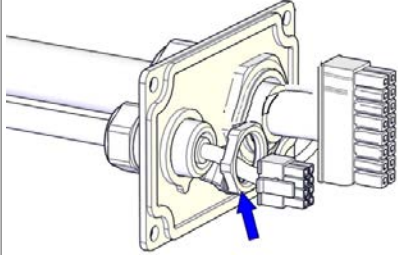
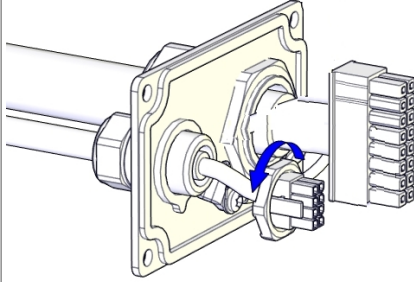
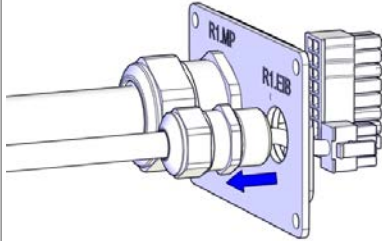
	Action	Note
2	Screw off the hexagonal lock nut.	 xx1500003006
3	Turn the lock nut gently against the connector to pull out the connector.	 xx1500003007
4	Remove the signal floor cable.	 xx1500003008

#### Refitting the floor cables

Use these procedures to refit the floor cables.

#### Assembling the signal floor cable

	Action	Note
1	Check the power floor cable. Replace if damaged.	

*Continues on next page*

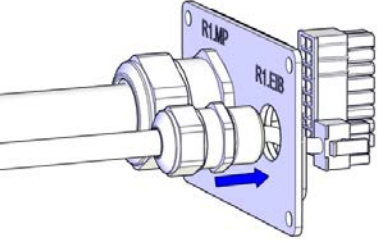
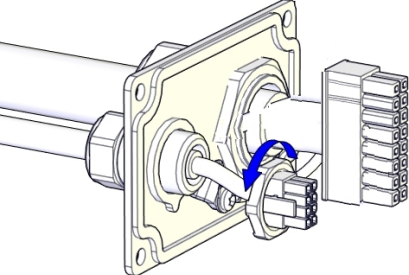
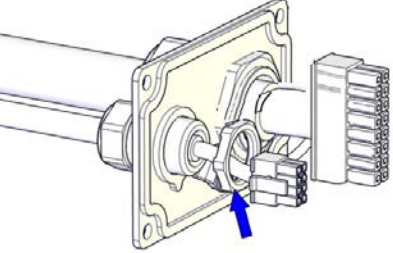
	Action	Note
2	Insert the signal floor cable.	 <p>xx1500003009</p>
3	Turn the hexagonal lock nut gently against the connector to enable the connector to move through the lock nut.	 <p>xx1500003007</p> <p><b>Lock nut: M16</b></p>
4	Secure the signal floor cable with the lock nut.	 <p>xx1500003006</p> <p><b>Tightening torque: 20 Nm</b></p>

*Continues on next page*

## 4 Repair

### 4.3.5 Replacing the floor cables

*Continued*

#### Reconnecting the floor cable connectors

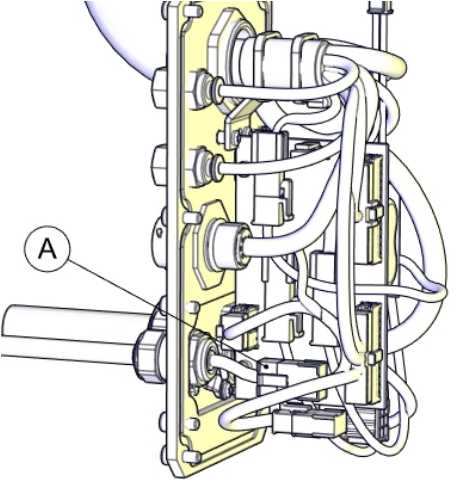
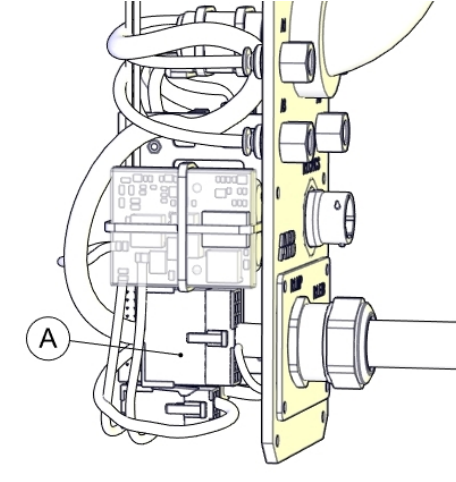
	Action	Note				
1	Reconnect the connectors. <ul style="list-style-type: none"><li>• R1.EIB</li><li>• R1.MP</li></ul>	 <p data-bbox="943 869 1050 891">xx150002202</p> <table border="1" data-bbox="943 907 1406 952"><tr><td data-bbox="943 907 997 952">A</td><td data-bbox="997 907 1406 952">R1.EIB</td></tr></table>  <p data-bbox="943 1451 1050 1473">xx150002203</p> <table border="1" data-bbox="943 1489 1406 1534"><tr><td data-bbox="943 1489 997 1534">A</td><td data-bbox="997 1489 1406 1534">R1.MP</td></tr></table>	A	R1.EIB	A	R1.MP
A	R1.EIB					
A	R1.MP					

*Continues on next page*

#### Refitting the floor cables

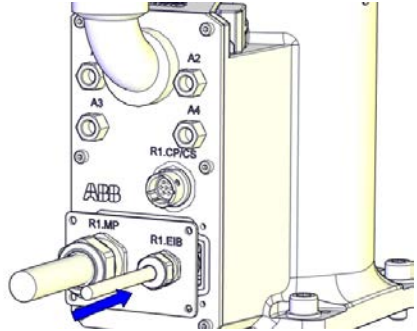
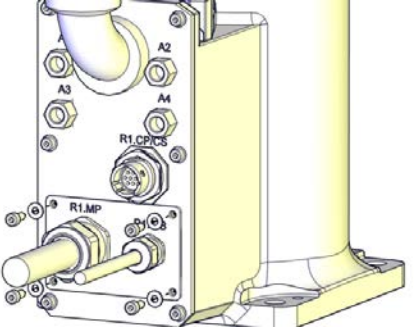
	Action	Note
1	Push the floor cables into place.	 <p>xx150003005</p>
2	Secure with screws and washers.	 <p>xx150003003</p> <p>Screw: M4x10 (4 pcs) Tightening torque: 2 Nm</p>

#### Concluding procedure

	Action	Note
1	Recalibrate the robot.	Calibration is detailed in section <a href="#">Calibration on page 349</a> .
2	 <p><b>DANGER</b></p> <p>Make sure all safety requirements are met when performing the first test run. These are further detailed in the section "First test run may cause injury or damage" in <i>Safety manual for robot - Manipulator and IRC5 or OmniCore controller</i>.</p>	

## 4 Repair

### 4.3.6 Replacing the brake release harness

### 4.3.6 Replacing the brake release harness

#### Location of the brake release harness

The brake release harness is located as shown in the figure.

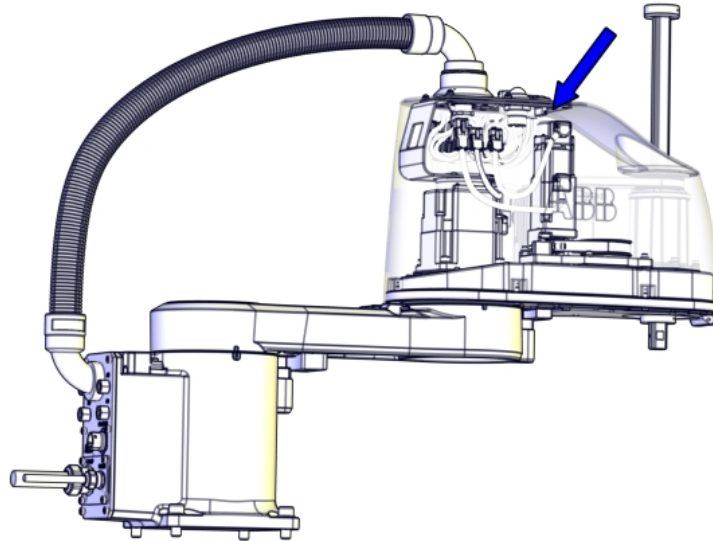

xx1800001421

#### Required spare parts



#### Note

The spare part numbers that are listed in the table can be out of date. See the latest spare parts of the IRB 910SC via myABB Business Portal, [www.abb.com/myABB](http://www.abb.com/myABB).

Spare part	Article number	Note
Brake release harness	3HAC038361-001	Includes brake release button and harness.



#### Required tools and equipment

Equipment, etc.	Article number	Note
Standard toolkit	-	Content is defined in section <a href="#">Standard toolkit on page 392</a> .
Trolley	-	

Continues on next page

Removing the brake release harness

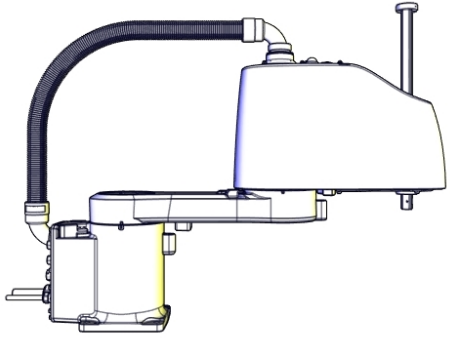
Preparations before removing the brake release harness

	Action	Note
1	Jog all axes to zero position.	 <p>xx1500002227</p>
2	 <b>DANGER</b> Turn off all: <ul style="list-style-type: none"> <li>• electric power supply</li> <li>• hydraulic pressure supply</li> <li>• air pressure supply</li> </ul> to the robot, before entering the robot working area.	

Removing the brake release harness

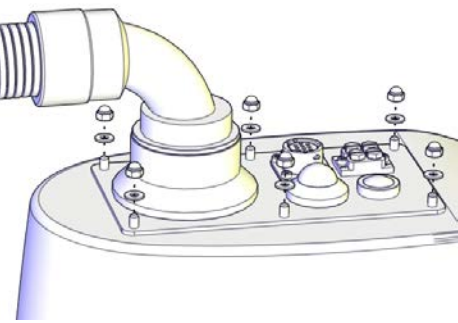

	Action	Note
1	 <b>DANGER</b> Make sure that all supplies for electrical power, hydraulic pressure, and air pressure are turned off.	
2	Remove the dome nuts and washers.	 <p>xx1500002182</p>

Continues on next page

## 4 Repair

### 4.3.6 Replacing the brake release harness

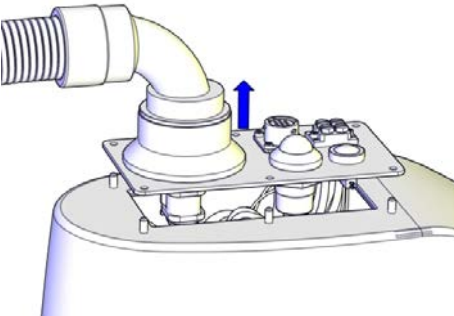
Continued

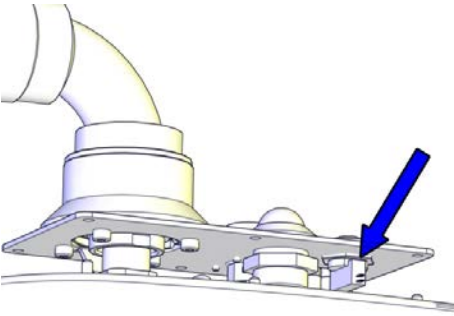
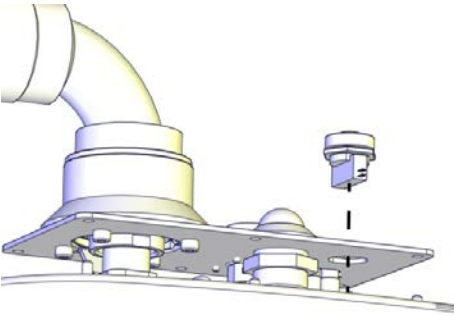
	Action	Note
3	<p>Carefully open the user interface plate and pull out the cable package.</p> <p> <b>CAUTION</b></p> <p>Do not pull out the plate completely.</p>	 <p>xx1500002183</p>
4	<p>Disconnect the brake release harness connector.</p> <ul style="list-style-type: none"><li>• R2.BR</li></ul> <p> <b>Tip</b></p> <p>Take photos of the connector and cable position before disconnection, to have as a reference when reconnecting.</p>	
5	<p>Remove the nut.</p>	 <p>xx1800001422</p>
6	<p>Carefully pull the brake release button out.</p>	 <p>xx1800001423</p>

Continues on next page



Refitting the brake release harness

Refitting the brake release harness

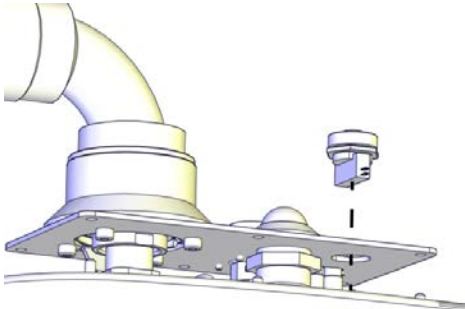
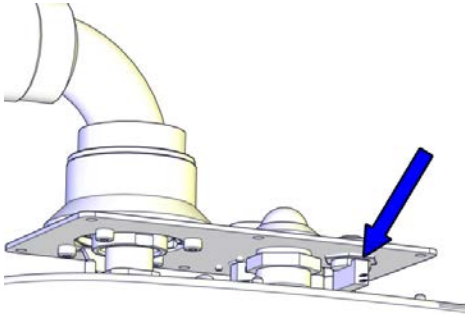
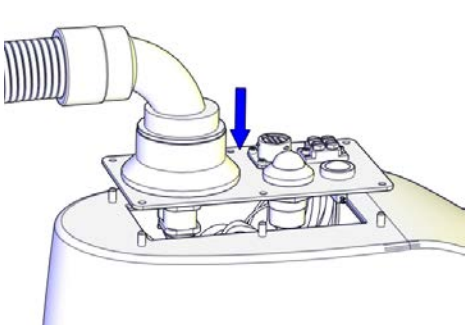
	Action	Note
1	<p>Gently push and pull the brake release harness through the mounting hole.</p> <p> <b>CAUTION</b></p> <p>Be careful not to bend or break the cables.</p>	 <p>xx1800001423</p>
2	<p>Refit the nut.</p>	 <p>xx1800001422</p>
3	<p>Connect the brake release harness connector.</p> <ul style="list-style-type: none"> <li>• R2.BR</li> </ul>	
4	<p>Push the main cable package into place.</p>	 <p>xx1500002207</p>

Continues on next page

## 4 Repair

### 4.3.6 Replacing the brake release harness

Continued

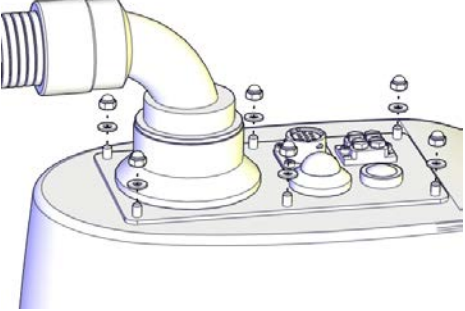
	Action	Note
5	Refit the user interface plate.	 <p data-bbox="943 645 1050 667">xx1500002182</p> <p data-bbox="943 680 1182 712">Dome nut: M4 (6 pcs)</p> <p data-bbox="943 714 1209 745">Tightening torque: 2 Nm</p> <p data-bbox="943 748 1102 779">Washer, 6 pcs</p>

#### Concluding procedure

	Action	Note
1	Recalibrate the robot.	Calibration is detailed in section <a href="#">Calibration on page 349</a> .
2	 <p data-bbox="557 1012 663 1043"><b>DANGER</b></p> <p data-bbox="464 1072 932 1234">Make sure all safety requirements are met when performing the first test run. These are further detailed in the section "First test run may cause injury or damage" in <i>Safety manual for robot - Manipulator and IRC5 or OmniCore controller</i>.</p>	

## 4.4 Upper arm

### 4.4.1 Replacing the upper arm

#### Location of the upper arm

The upper arm is located as shown in the figure.

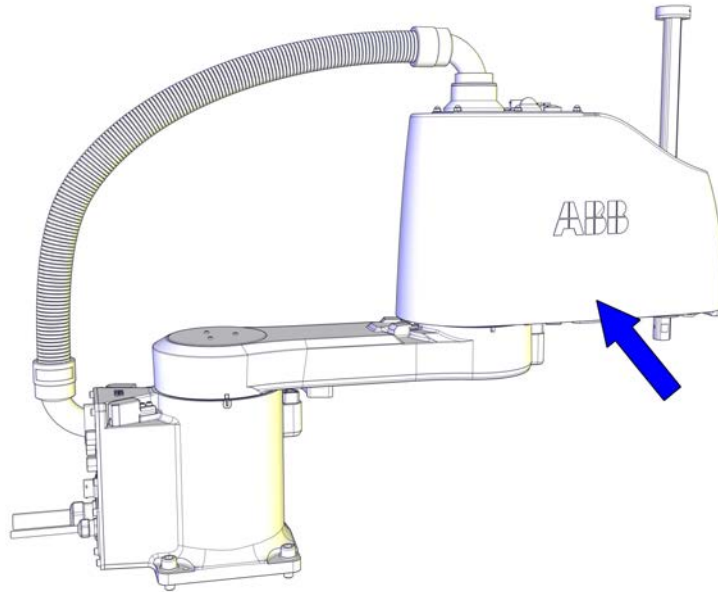

xx1500002209

#### Required spare parts



#### Note

The spare part numbers that are listed in the table can be out of date. See the latest spare parts of the IRB 910SC via myABB Business Portal, [www.abb.com/myABB](http://www.abb.com/myABB).

Spare part	Article number	Note
Upper arm body	3HAC057711-001	
Upper cover unit	3HAC057615-001	Includes upper cover and cover flange.
Lower cover	3HAC060106-001	Replace if damaged.
Plate for upper arm cable harness	3HAC056086-001	Replace if damaged.
Axis-4 housing with idler	3HAC056121-001	Replace if damaged.
Axis-3 drive unit housing	3HAC055184-001	Replace if damaged.
Adjusting block for axis-3 timing belt	3HAC056650-001	Replace if damaged.

*Continues on next page*

## 4 Repair

### 4.4.1 Replacing the upper arm

*Continued*

Spare part	Article number	Note
Adjusting block for upper axis-4 timing belt	3HAC056651-001	Replace if damaged.
Adjusting block for lower axis-4 timing belt	3HAC056652-001	Replace if damaged.
Plain washer	3HAC056937-001	Replace if damaged.
Axis-2 mechanical stop block	3HAC055185-001	Replace if damaged.

### Required tools and equipment

Equipment	Article number	Note
Standard toolkit	-	The content is defined in the section <a href="#">Standard toolkit on page 392</a> .
Sonic tensiometer	-	Used for measuring the timing belt tension.
Dynamometer	-	Used for measuring the timing belt tension.

### Required consumables



Consumable	Article number	Note
Grease	-	THK AFA Used for lubricating the ball screw spline shaft.
Cable ties	-	

*Continues on next page*

**Removing the upper arm**

Use these procedures to remove the upper arm from the lower arm.

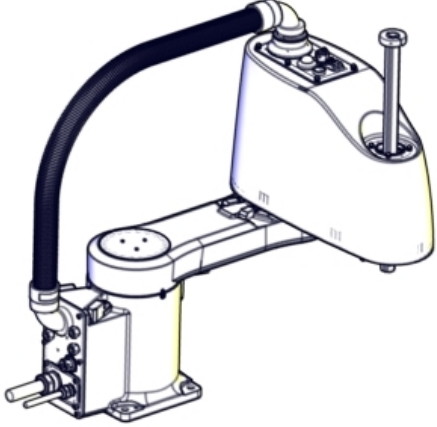
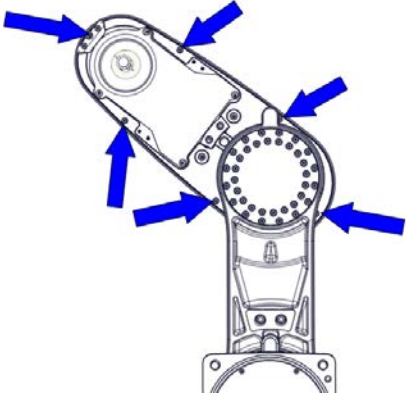
**Preparations before removing the upper arm**

	Action	Note
1	Jog axis 2 to access the cover screws.	 <p data-bbox="973 952 1077 974">xx1500002520</p>  <p data-bbox="973 1400 1077 1422">xx1500002782</p>
2	 <p data-bbox="582 1489 694 1523"><b>DANGER</b></p> <p data-bbox="494 1545 917 1736">Turn off all:</p> <ul data-bbox="526 1579 861 1680" style="list-style-type: none"> <li>• electric power supply</li> <li>• hydraulic pressure supply</li> <li>• air pressure supply</li> </ul> <p data-bbox="494 1680 917 1736">to the robot, before entering the robot working area.</p>	



Continues on next page

## 4 Repair

### 4.4.1 Replacing the upper arm

*Continued*

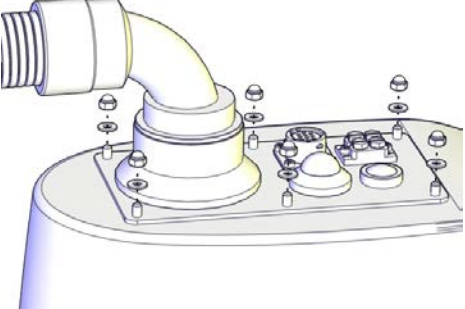

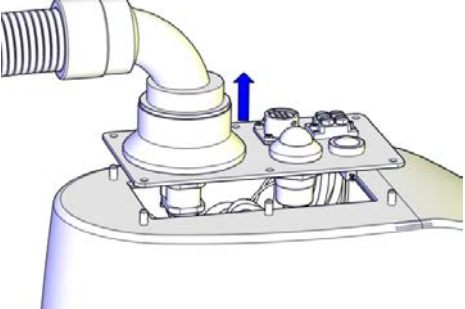
Removing the main cable package from the upper arm

	Action	Note
1	 <b>DANGER</b> Make sure that all supplies for electrical power, hydraulic pressure, and air pressure are turned off.	
2	Remove the dome nuts and washers.	 xx1500002182
3	 <b>CAUTION</b> The plate cannot be removed completely until the connectors are disconnected, as shown in the following step.	 xx1500002183

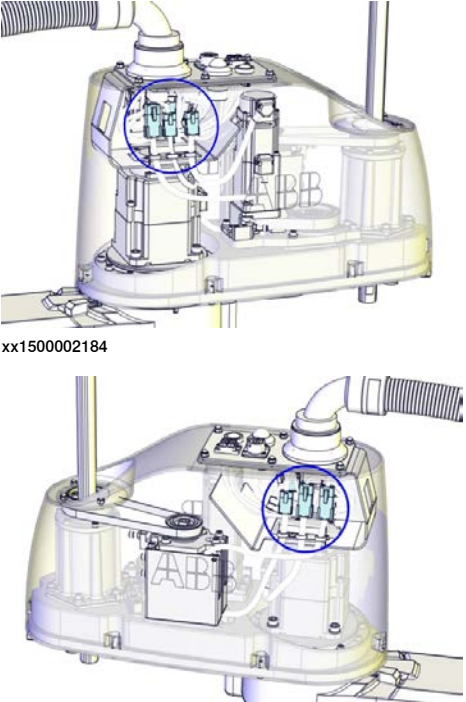
*Continues on next page*

	Action	Note
4	<p>Disconnect the connectors:</p> <ul style="list-style-type: none"> <li>• R2.MP2</li> <li>• R2.MP3</li> <li>• R2.MP4</li> <li>• R2.ME2</li> <li>• R2.ME3</li> <li>• R2.ME4</li> </ul> <p> <b>Tip</b></p> <p>Take photos of the connectors and cable position before disconnecting them, to have as a reference when reconnecting.</p>	

### Removing the upper cover

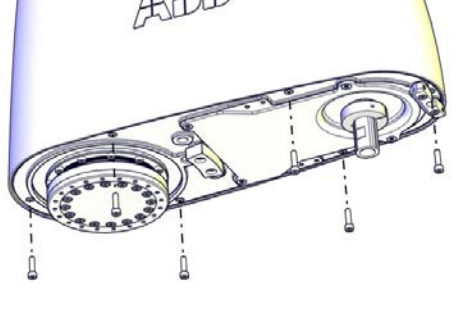
	Action	Note
1	<p> <b>DANGER</b></p> <p>Make sure that all supplies for electrical power, hydraulic pressure, and air pressure are turned off.</p>	
2	<p> <b>WARNING</b></p> <p>Risk of tipping. Make sure the robot is well secured and that the upper arm is supported during the removal work.</p>	
3	<p>Remove the screws.</p>	

Continues on next page

## 4 Repair

### 4.4.1 Replacing the upper arm

*Continued*

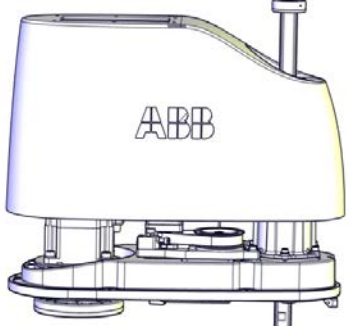
	Action	Note
4	 <b>WARNING</b> The cover may be damaged due to improper shift. Keep the cover in position while removing the screws.	
5	Lift out the upper cover carefully.	 xx1500002221

### Removing the lower stop block

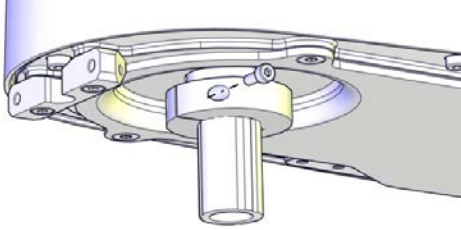

	Action	Note
1	 <b>DANGER</b> Make sure that all supplies for electrical power, hydraulic pressure, and air pressure are turned off.	
2	Remove the lower stop block of ball screw spline unit to replace: <ul style="list-style-type: none"><li>• lower cover of the upper arm</li><li>• ball screw spine unit</li><li>• upper arm body</li></ul>	
3	Remove the screws.	 xx1500002222

*Continues on next page*

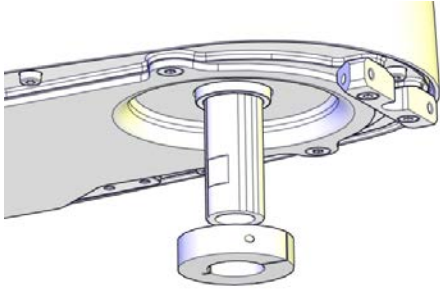

	Action	Note
4	Remove the stop block.	 <p>xx1500002223</p>

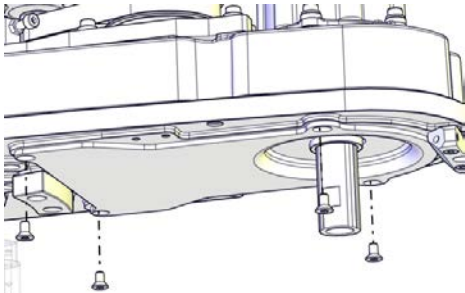
#### Removing the lower cover

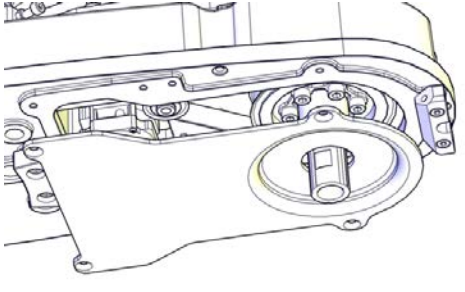
	Action	Note
1	 <p><b>DANGER</b></p> <p>Make sure that all supplies for electrical power, hydraulic pressure, and air pressure are turned off.</p>	
2	Remove the screws.	 <p>xx1500002785</p>
3	<p>Remove the cover.</p>  <p><b>Tip</b></p> <p>If only working with lower axis-4 timing belt, no need to remove the stop block of ball screw spline unit before removing the lower cover.</p>	 <p>xx1500002225</p>



*Continues on next page*

## 4 Repair

### 4.4.1 Replacing the upper arm

*Continued*

#### Removing the drive unit cables

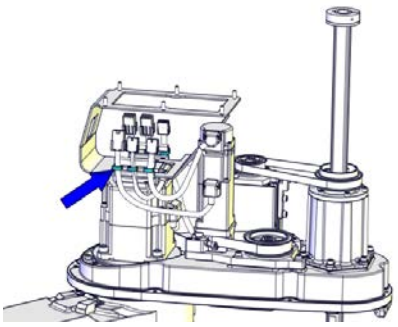
	Action	Note
1	 <b>DANGER</b> Make sure that all supplies for electrical power, hydraulic pressure, and air pressure are turned off.	
2	Cut the cable ties. Be careful not to damage the cabling.   <b>Tip</b> Take photos of the cable position before removing them, to have as a reference when refitting.	 <small>xx1500002226</small>

#### Removing the cable harness plate

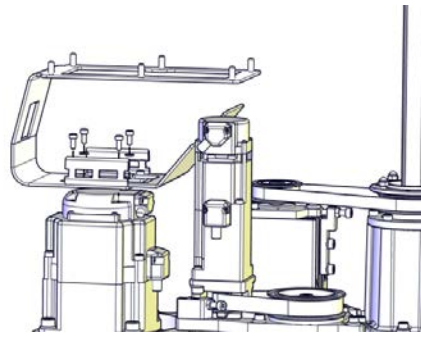
	Action	Note
1	 <b>DANGER</b> Make sure that all supplies for electrical power, hydraulic pressure, and air pressure are turned off.	
2	Remove the screws and washers.	 <small>xx1500002228</small>
3	Remove the cable harness plate.	



#### Removing the axis-3 timing belt

	Action	Note
1	 <b>DANGER</b> Make sure that all supplies for electrical power, hydraulic pressure, and air pressure are turned off.	

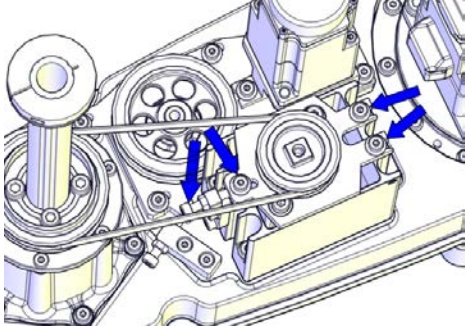
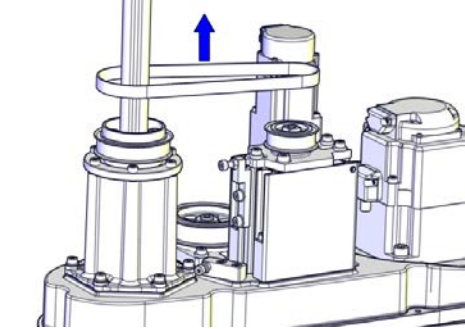
*Continues on next page*

	Action	Note
2	 <b>WARNING</b> Risk of tipping. Make sure the gravity center is well supported.	
3	Loosen the screws and move the axis-3 drive unit upwards to slacken the timing belt.	 <p>xx1500002229</p>
4	Remove the timing belt.	 <p>xx1500002230</p>

Removing the lower axis-4 timing belt

	Action	Note
1	 <b>DANGER</b> Make sure that all supplies for electrical power, hydraulic pressure, and air pressure are turned off.	
2	 <b>WARNING</b> Risk of tipping. Make sure the gravity center is well supported.	

Continues on next page

## 4 Repair

### 4.4.1 Replacing the upper arm

*Continued*

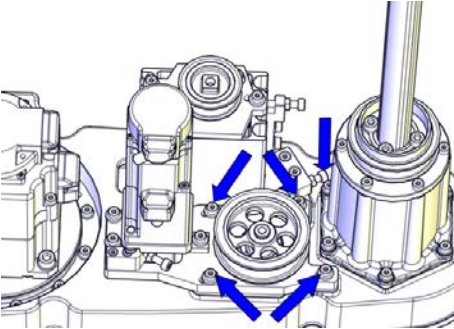
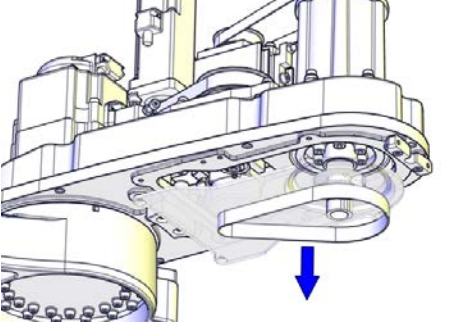
	Action	Note
3	Loosen the screws and move the axis-4 housing sideways to slacken the lower axis-4 timing belt.	 <p>xx1500002231</p>
4	Remove the timing belt.	 <p>xx1500002232</p>

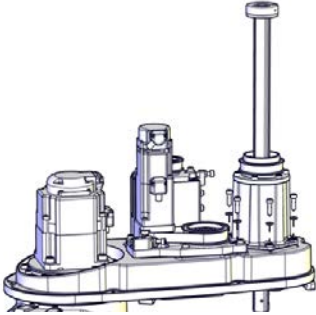

### Removing the ball screw spline

	Action	Note
1	 <p><b>DANGER</b></p> <p>Make sure that all supplies for electrical power, hydraulic pressure, and air pressure are turned off.</p>	
2	Remove the screws.	 <p>xx1500002788</p>

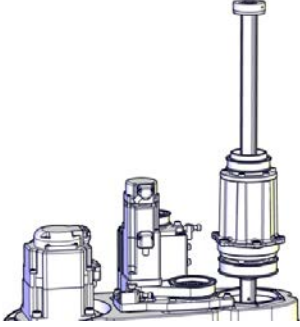
*Continues on next page*

	Action	Note
3	Remove the ball screw spline unit.	 <p>xx1500002787</p>

#### Removing the axis-4 drive unit and upper timing belt

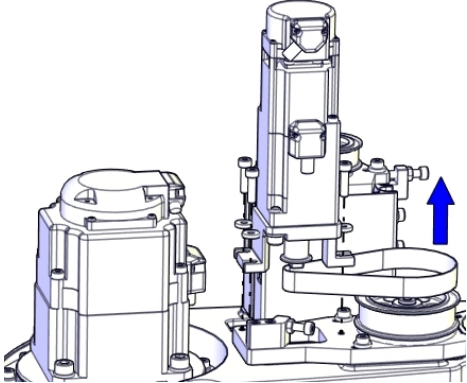
	Action	Note
1	 <p><b>DANGER</b></p> <p>Make sure that all supplies for electrical power, hydraulic pressure, and air pressure are turned off.</p>	
2	 <p><b>WARNING</b></p> <p>Risk of tipping. Make sure the gravity center is well supported.</p>	
3	Loosen the screws and move the axis-4 drive unit upwards to slacken the upper axis-4 timing belt.	 <p>xx1500002233</p>

*Continues on next page*



## 4 Repair

### 4.4.1 Replacing the upper arm

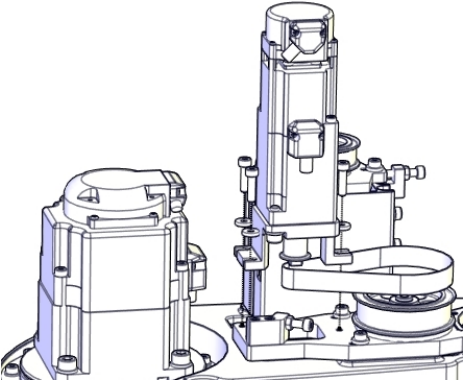
*Continued*

	Action	Note
4	Remove the drive unit and timing belt.	 <p>xx1500002234</p>

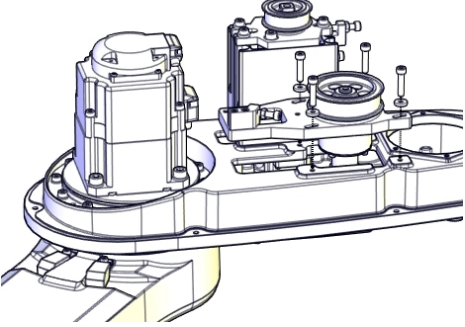

### Removing the axis-4 housing with idler

	Action	Note
1	 <p><b>DANGER</b></p> <p>Make sure that all supplies for electrical power, hydraulic pressure, and air pressure are turned off.</p>	
2	 <p><b>WARNING</b></p> <p>There is a risk of tipping during the removal. Make sure the gravity center is well supported.</p>	
3	Remove the axis-4 housing with idler.	 <p>xx1500002235</p>

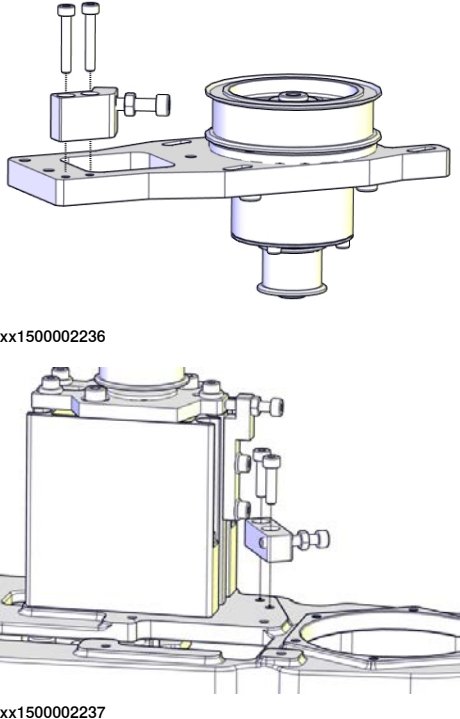
*Continues on next page*

	Action	Note
4	Remove the adjusting blocks.	 <p>xx1500002236</p> <p>xx1500002237</p>

Removing the axis-3 housing and axis-3 drive unit

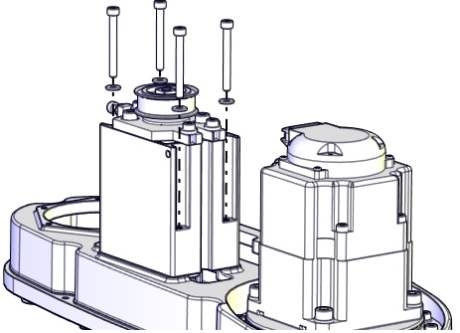

	Action	Note
1	 <p><b>DANGER</b></p> <p>Make sure that all supplies for electrical power, hydraulic pressure, and air pressure are turned off.</p>	
2	 <p><b>WARNING</b></p> <p>Risk of tipping. Make sure the gravity center is well supported.</p>	
3	Remove the screws and washers.	 <p>xx1500002810</p>

Continues on next page

## 4 Repair

### 4.4.1 Replacing the upper arm

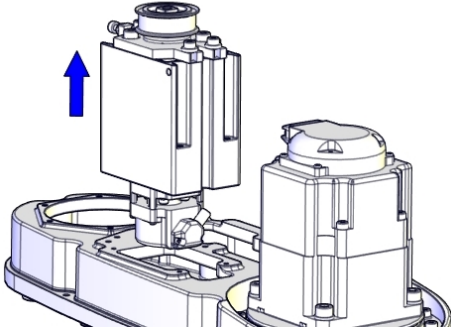
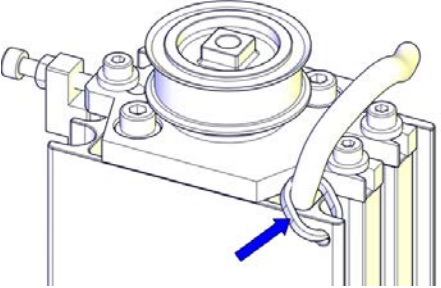
Continued

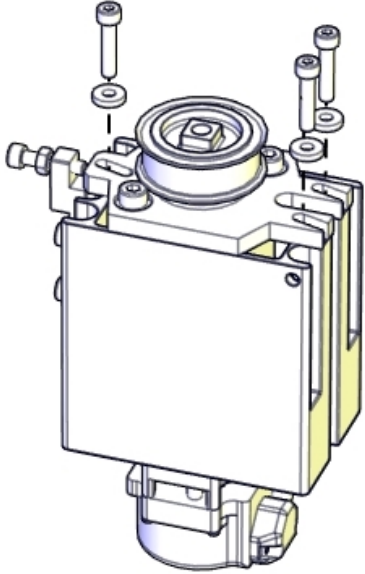
	Action	Note
4	Lift out the axis-3 housing and drive unit.	 xx1500002238
5	Cut the cable tie. Be careful not to damage the cabling.	 xx1500002815
6	Remove the screws.  <b>WARNING</b> Do not remove the other screws. They hold the gearbox together. Removing them can damage the gearbox severely.	 xx1500002797

Continues on next page

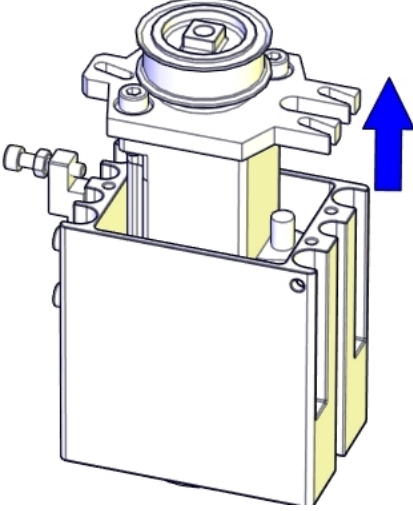

	Action	Note
7	Lift out the axis-3 drive unit carefully.	 <p>xx1500002239</p>

Removing the axis-3 timing belt adjusting block

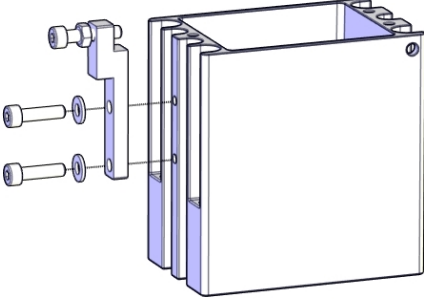
	Action	Note
1	 <b>DANGER</b> Make sure that all supplies for electrical power, hydraulic pressure, and air pressure are turned off.	
2	Remove the adjusting block.	 <p>xx1500002240</p>

Removing the upper arm body



	Action	Note
1	 <b>DANGER</b> Make sure that all supplies for electrical power, hydraulic pressure, and air pressure are turned off.	

Continues on next page

## 4 Repair

### 4.4.1 Replacing the upper arm



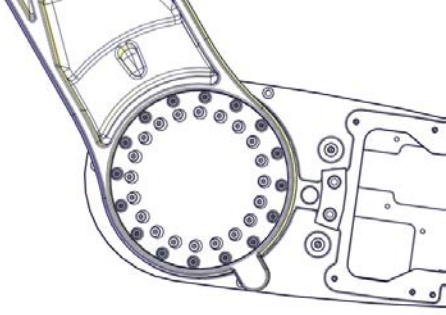
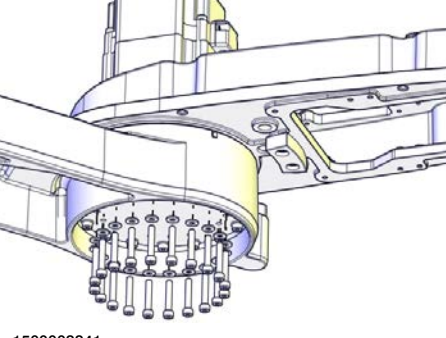
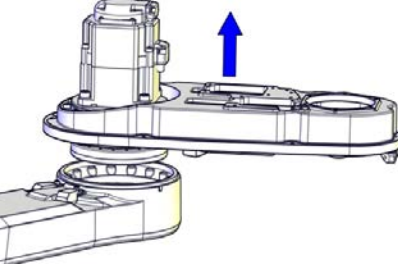

Continued

	Action	Note
2	<p> <b>WARNING</b></p> <p>The upper arm body with the axis-2 drive unit weights 7 kg. Make sure the weight of the upper arm body is properly supported, or it may drop when it is released from the lower arm.</p>	
3	<p>Remove the screws and washers.</p> <p> <b>WARNING</b></p> <p>Keep the twelve screws in the outer circle fitted. They hold the axis-2 motor flange on the lower arm.</p>  <p>xx1500002242</p>	 <p>xx1500002241</p>
4	<p>Remove the upper arm body and lay it aside on a workbench.</p>	 <p>xx1500002799</p>

### Removing the axis-2 drive unit

	Action	Note
1	<p> <b>DANGER</b></p> <p>Make sure that all supplies for electrical power, hydraulic pressure, and air pressure are turned off.</p>	

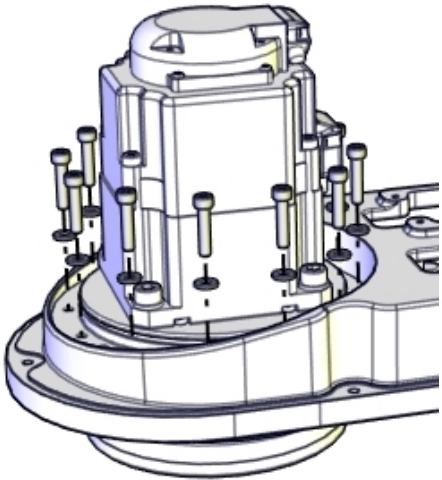
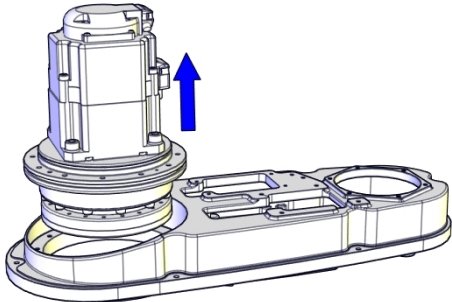
Continues on next page

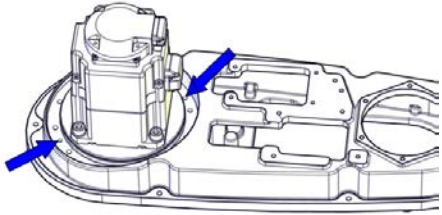
	Action	Note
2	 <b>WARNING</b> There is a risk of tipping during the removal. Make sure the gravity center is well supported.	
3	Remove the screws.  <b>WARNING</b> Do not remove the other screws. They hold the gearbox together. Removing them can damage the gearbox severely.	 <p data-bbox="970 1099 1078 1117">xx1500002800</p>
4	Lift out the drive unit.	 <p data-bbox="970 1503 1078 1520">xx1500002243</p>
5	 <b>Tip</b> If the drive unit is hard to remove, insert two M3 screws and press out the drive unit.	 <p data-bbox="970 1890 1078 1908">xx1500002244</p>

Continues on next page

## 4 Repair

### 4.4.1 Replacing the upper arm

*Continued*

#### Removing the axis-2 mechanical stop block

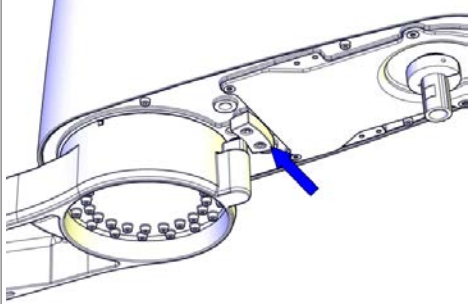
	Action	Note
1	 <b>DANGER</b> Make sure that all supplies for electrical power, hydraulic pressure, and air pressure are turned off.	
2	Remove the axis-2 mechanical stop block.	 xx1500003062 See <a href="#">Replacing the axis-2 mechanical stop on page 274</a> .

#### Refitting the upper arm

Use these procedures to refit the upper arm.

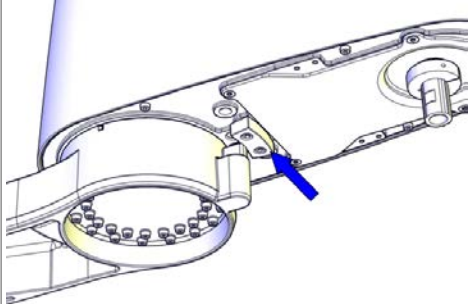

#### Refitting axis-2 mechanical stop block

	Action	Note
1	Refit the axis-2 mechanical stop block with screws.	 xx1500003062 See <a href="#">Replacing the axis-2 mechanical stop on page 274</a> .

#### Refitting the axis-2 drive unit

	Action	Note
1	Make sure that: <ul style="list-style-type: none"><li>• all assembly surfaces are clean and undamaged.</li><li>• the drive unit is clean and undamaged.</li></ul>	

*Continues on next page*

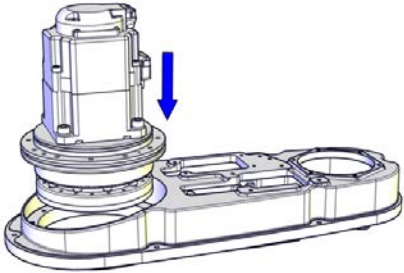
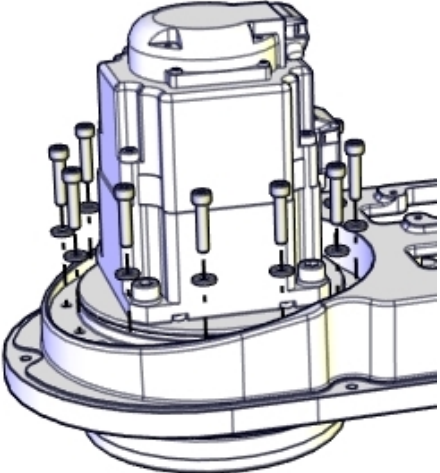
	Action	Note
2	<p>Refit the drive unit.</p> <p> <b>CAUTION</b></p> <p>Do not mix axis-1 and axis-2 drive units. Always check the mark or label on the drive units before refitting.</p> <p> <b>Note</b></p> <p>Make sure to refit the drive unit with the motor connectors pointing to the ball screw spline unit location.</p>	<p>Axis-2 drive unit: 3HAC056153-001</p>  <p>xx1500003068</p>
3	<p>Secure with screws and washers.</p>	 <p>xx1500002800</p> <p>Screw: M4x25 (12 pcs) Tightening torque: 4.5 Nm Washer: 4.3x9x1 (12 pcs)</p>

Continues on next page

## 4 Repair

### 4.4.1 Replacing the upper arm

*Continued*

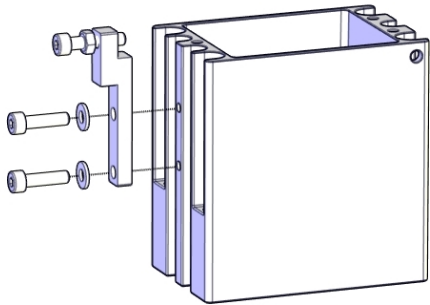

#### Refitting the axis-3 timing belt adjusting block

	Action	Note
1	Refit the adjusting block.	<p>Adjusting block: 3HAC056651-001</p>  <p>xx1500002240</p> <p>Screw: M4x16 (2 pcs) Tightening torque: 4.5 Nm</p>

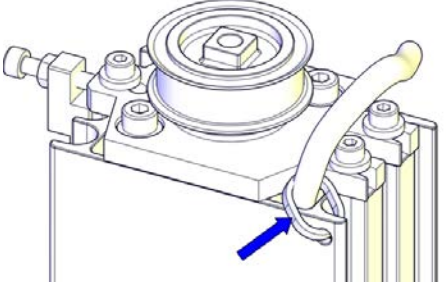
#### Refitting the axis-3 housing and axis-3 drive unit

	Action	Note
1	Refit the drive unit with one cabling coming out from the upside and the other coming out from the downside.   <b>Note</b>  Make sure to refit the drive unit correctly oriented with the lugs of the drive unit bracket as a reference.	Axis-3 drive unit: 3HAC056111-001 Axis-3 drive unit housing: 3HAC055184-001
2	Secure the upper cabling with a cable tie. Do not tighten the tie too tight.	 <p>xx1500002815</p>

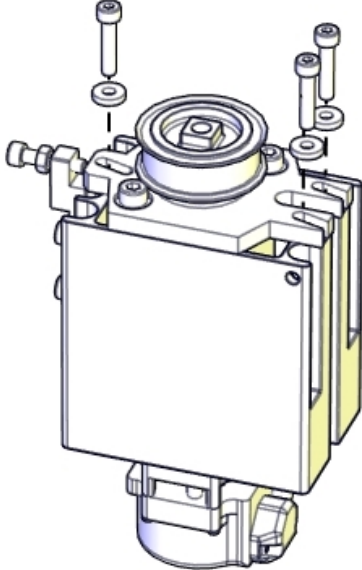
*Continues on next page*

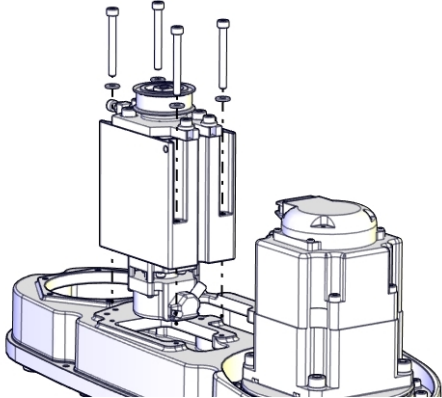
	Action	Note
3	Refit drive unit screws and washers just enough to still be able to move the drive unit.	 <p data-bbox="970 920 1078 938">xx1500002797</p> <p data-bbox="970 958 1350 1055">Screw: M4x20 (3 pcs) Tightening torque: 4.5 Nm Washer (3HAC056937-001, 3 pcs)</p> <p data-bbox="975 1072 1034 1128"> <b>Note</b></p> <p data-bbox="970 1144 1437 1196">Only use specified washers, never replace them with other washers.</p>
4	Refit the housing with drive unit.	 <p data-bbox="970 1637 1078 1655">xx1500002798</p> <p data-bbox="970 1675 1262 1771">Screw: M4x40 (4 pcs) Tightening torque: 3.5 Nm Washer: M4 (4 pcs)</p>



Continues on next page

## 4 Repair

### 4.4.1 Replacing the upper arm

*Continued*

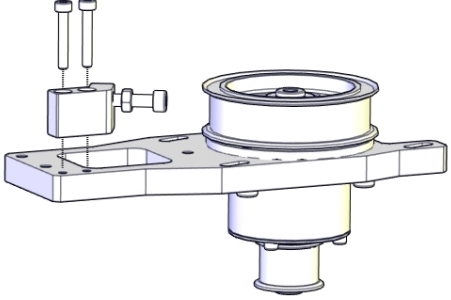
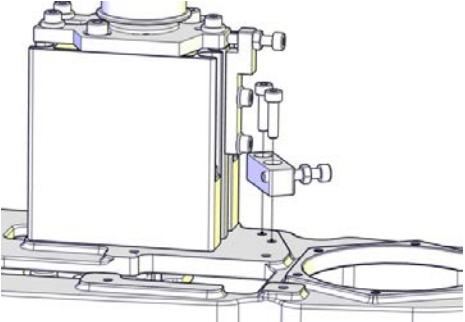
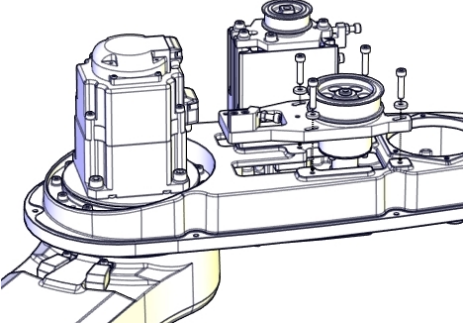

#### Refitting the axis-4 housing with idler

	Action	Note
1	Refit the adjusting blocks.	<p>Adjusting block for upper timing belt: 3HAC056651-001</p>  <p>xx1500002236</p> <p>Screw: M3x20 (2 pcs) Adjusting block for lower timing belt: 3HAC056652-001</p>  <p>xx1500002237</p> <p>Screw: M4x16 (2 pcs) Tightening torque: 4.5 Nm</p>
2	Refit the housing with idler and fasten the screws and washers just enough to still be able to move the housing sideways.	 <p>xx1500002235</p> <p>Screw: M4x20 (4 pcs) Washer (3HAC056937-001, 4 pcs)</p> <p> <b>Note</b> Only use specified washers, never replace them with other washers.</p>

*Continues on next page*

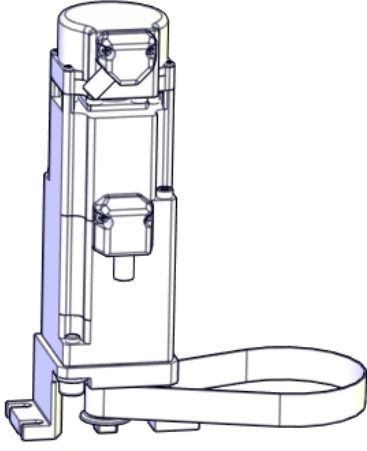

Refitting the axis-4 drive unit and upper timing belt

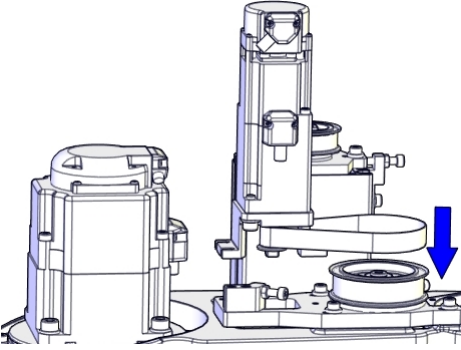

	Action	Note
1	<p>Make sure that:</p> <ul style="list-style-type: none"> <li>all assembly surfaces are clean and undamaged.</li> <li>the drive unit is clean and undamaged.</li> </ul>	
2	<p>Place the timing belt.</p>	<p>Axis-4 drive unit: 3HAC056112-001 Upper axis-4 timing belt: 3HAC055206-001</p>  <p>xx1500002801</p>
3	<p>Refit the drive unit and timing belt.</p> <p> <b>Note</b></p> <p>Make sure to refit the drive unit with motor connectors pointing against axis-3 drive unit.</p>	 <p>xx1500002802</p>

Continues on next page

## 4 Repair

### 4.4.1 Replacing the upper arm

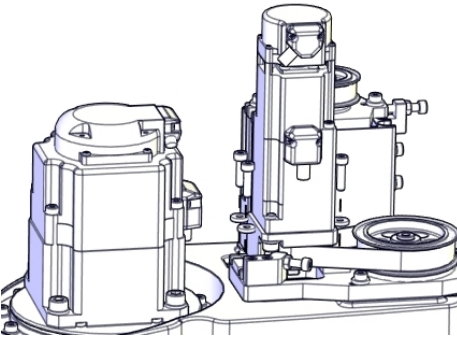
Continued

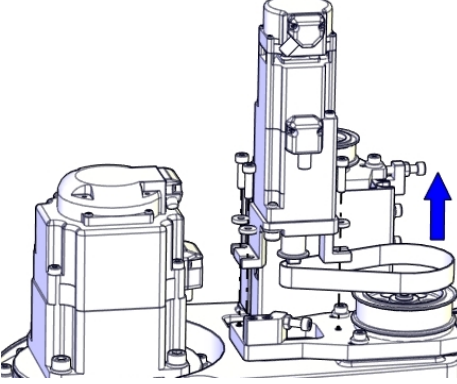
	Action	Note
4	Refit screws and washers just enough to still be able to move the drive unit upwards.	 <p data-bbox="943 674 1050 689">xx1500002803</p> <p data-bbox="943 712 1321 772">Screw: M4x16 (3 pcs) Washer (3HAC056937-001, 3 pcs)</p> <p data-bbox="943 790 1002 846"> <b>Note</b></p> <p data-bbox="943 864 1406 913">Only use specified washers, never replace them with other washers.</p>
5	Fasten the screws little by little while using a dynamometer to measure the belt tension until a proper belt tension is achieved.	 <p data-bbox="943 1357 1050 1373">xx1500002233</p> <p data-bbox="943 1395 1406 1574">Belt tension: <math>F = 37 \text{ N}</math> (Recommended) Belt tension range: 24.1 N to 27.6 N (for used timing belt, which has been installed and used for more than 24 hours) 34.5 N to 37.9 N (for new timing belt)</p>

### Refitting the ball screw spline unit

	Action	Note
1	Make sure that: <ul style="list-style-type: none"> <li>• all assembly surfaces are clean and undamaged.</li> <li>• the ball screw spline unit is well-lubricated and undamaged.</li> </ul>	See <a href="#">Lubricating the ball screw spline unit on page 113</a> .
2	If a new ball screw spline unit is used, remove the lower stop block to enable fitting of the lower cover.	See "Removing the lower stop block" in <a href="#">Removing the ball screw spline unit on page 234</a> .

Continues on next page

### 4.4.1 Replacing the upper arm Continued

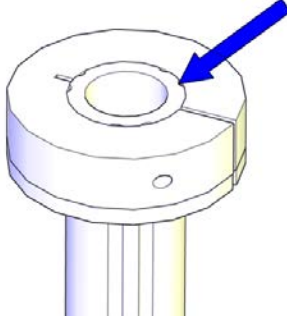
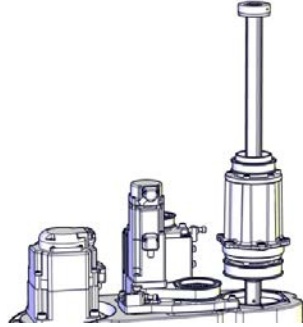
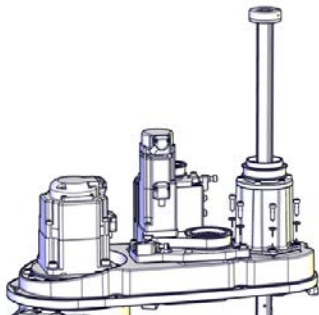
	Action	Note
3	<p>Check the upper stop block of the ball screw spline unit. Replace if damaged. Make sure the upper surfaces of the shaft and stop block are at the same level.</p>	<p>Upper axis-3 and axis-4 mechanical stop block: 3HAC061259-001</p>  <p>xx1600002115</p>
4	<p>Refit the ball screw spline unit.</p>	<p>Ball screw spline unit: 3HAC056148-001</p>  <p>xx1500002787</p>
5	<p>Secure with screws and washers.</p>	 <p>xx1500002788</p> <p>Screw: M4x16 (6 pcs) Tightening torque: 4.5 Nm Washer: M4 (6 pcs)</p>

#### Refitting the lower axis-4 timing belt

	Action	Note
1	<p>Make sure that:</p> <ul style="list-style-type: none"> <li>all assembly surfaces are clean and undamaged.</li> <li>the drive unit is clean and undamaged.</li> </ul>	

Continues on next page

## 4 Repair

### 4.4.1 Replacing the upper arm

Continued

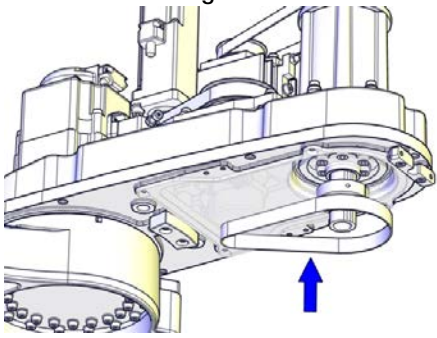
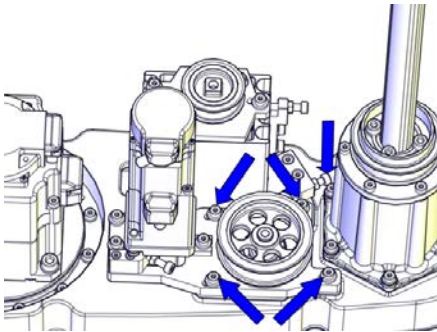
	Action	Note
2	Refit lower axis-4 timing belt. Ensure that the belt runs correctly in the grooves.	<p>Lower axis-4 timing belt: 3HAC055201-001</p>  <p>xx1500002786</p>
3	Fasten the screws little by little while using a dynamometer to measure the belt tension until a proper belt tension is achieved.	 <p>xx1500002231</p> <p>Belt tension: <math>F = 101 \text{ N}</math> (Recommended)            Belt tension range:            64.5 N to 73.7 N (for used timing belt, which has been installed and used for more than 24 hours)            92.2 N to 101 N (for new timing belt)</p>

### Refitting the axis-3 timing belt

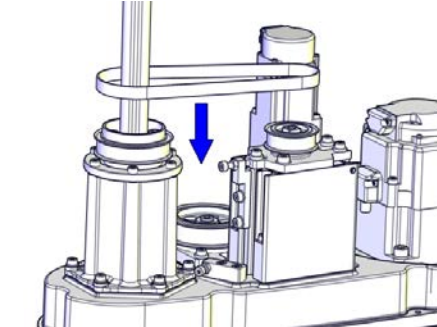
	Action	Note
1	Make sure that: <ul style="list-style-type: none"> <li>• all assembly surfaces are clean and undamaged.</li> <li>• the drive unit is clean and undamaged.</li> </ul>	
2	Refit axis-3 timing belt. Ensure that the belt runs correctly in the grooves.	<p>Axis-3 timing belt: 3HAC055209-001</p>  <p>xx1500002789</p>

Continues on next page

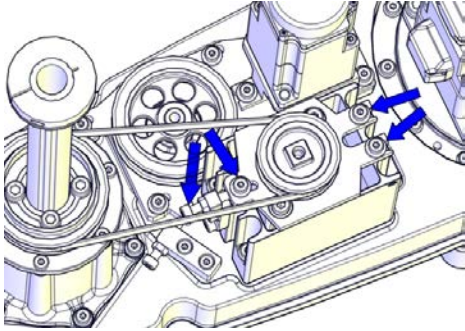
	Action	Note
3	Fasten the screws little by little while using a dynamometer to measure the belt tension until a proper belt tension is achieved.	 <p data-bbox="970 645 1082 667">xx150002229</p> <p data-bbox="970 680 1406 712">Belt tension: <math>F = 34 \text{ N}</math> (Recommended)</p> <p data-bbox="970 719 1182 745">Belt tension range:</p> <p data-bbox="970 752 1437 831">21.8 N to 24.9 N (for used timing belt, which has been installed and used for more than 24 hours)</p> <p data-bbox="970 837 1358 864">31.1 to 34.2 N (for new timing belt)</p>

#### Refitting the cable harness plate

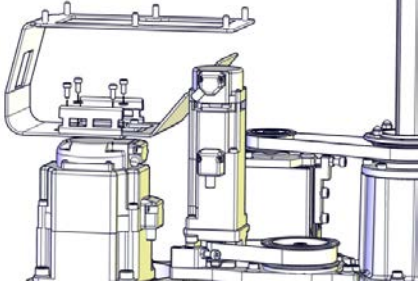
	Action	Note
1	Refit the cable harness plate.	 <p data-bbox="970 1323 1082 1346">xx150002228</p> <p data-bbox="970 1359 1198 1391">Screw: M3x8 (4 pcs)</p> <p data-bbox="970 1397 1262 1429">Tightening torque: 1.5 Nm</p> <p data-bbox="970 1435 1182 1467">Washer: M3 (4 pcs)</p>
2	Secure with screws and washers.	

## 4 Repair

### 4.4.1 Replacing the upper arm

*Continued*

#### Securing the drive unit cables

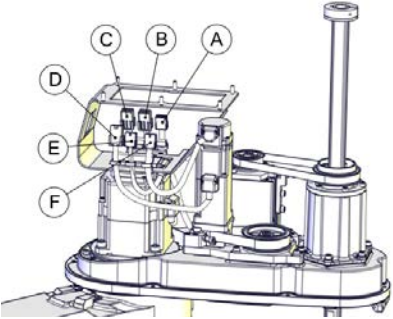
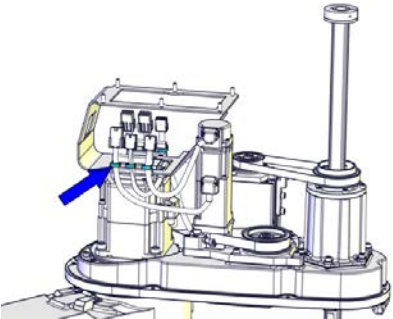
	Action	Note												
1	Put the drive unit cables in place.	 <p>xx1500003063</p> <table border="1" data-bbox="943 734 1406 1010"> <tr> <td>A</td> <td>R2.ME3</td> </tr> <tr> <td>B</td> <td>R2.MP2</td> </tr> <tr> <td>C</td> <td>R2.MP3</td> </tr> <tr> <td>D</td> <td>R2.MP4</td> </tr> <tr> <td>E</td> <td>R2.ME2</td> </tr> <tr> <td>F</td> <td>R2. ME4</td> </tr> </table>	A	R2.ME3	B	R2.MP2	C	R2.MP3	D	R2.MP4	E	R2.ME2	F	R2. ME4
A	R2.ME3													
B	R2.MP2													
C	R2.MP3													
D	R2.MP4													
E	R2.ME2													
F	R2. ME4													
2	Secure the cables with cable ties. Do not tighten the ties too tight.	 <p>xx1500002226</p>												

#### Refitting the upper cover

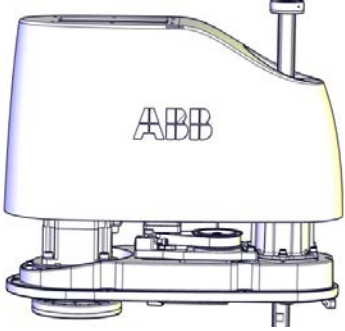
	Action	Note
1	Carefully put down the upper cover, avoiding any collision to the ball screw spline unit and drive units.	<p>Upper cover unit: 3HAC057615-001</p>  <p>xx1500002221</p>

*Continues on next page*

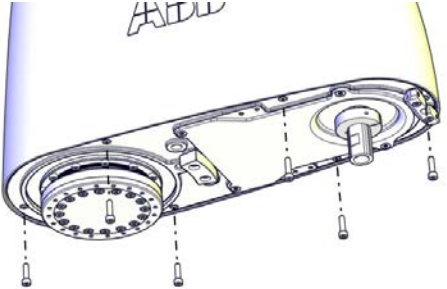
	Action	Note
2	 <b>Tip</b> Some of the screws are accessed from below. Make sure that the robot is properly fastened and hang out the upper arm from the workbench to access them.	
3	Refit the cover.	 <p>xx1500002220</p> <p>Screw: M4x16 (6 pcs) Tightening torque: 2 Nm</p>

#### Refitting the lower cover

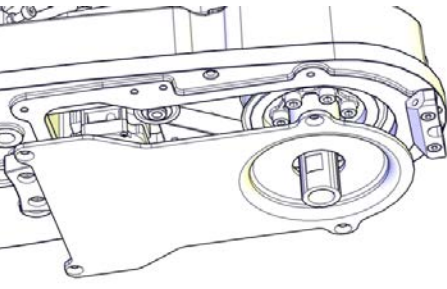
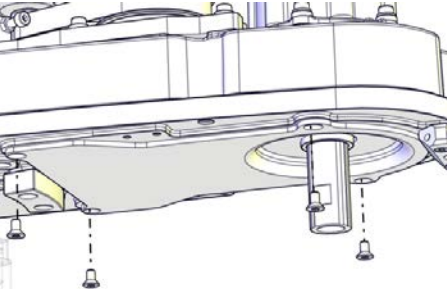
	Action	Note
1	Refit the cover.	<p>Lower cover: 3HAC060106-001</p>  <p>xx1500002225</p>
2	Secure with screws.	 <p>xx1500002785</p> <p>Screw: M4x8 (4 pcs) Tightening torque: 2 Nm</p>



*Continues on next page*

## 4 Repair

### 4.4.1 Replacing the upper arm

*Continued*

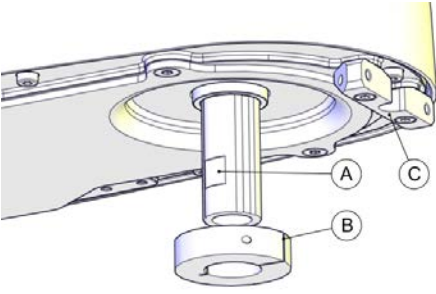
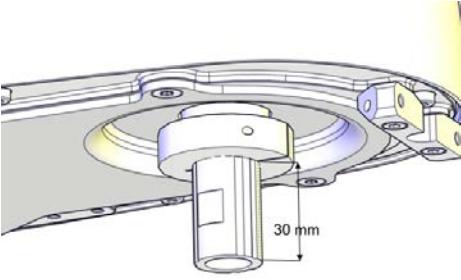
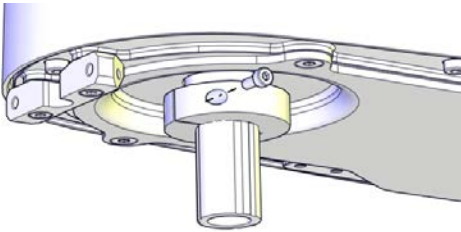
#### Refitting the lower stop block

	Action	Note						
1	<p>Check the lower stop block of the ball screw spline unit. Replace if damaged.</p>	<p>Lower axis-3 and axis-4 mechanical stop block: 3HAC055208-001</p>						
2	<p>Refit the lower stop block. Make the notch point to the calibration block and 90° away from the flat mark on the shaft. Make sure the distance between the lower surfaces of stop block and shaft is 30 mm.</p>	<div data-bbox="943 465 1380 757">  </div> <p data-bbox="943 801 1050 824">xx1500002908</p> <table border="1" data-bbox="943 842 1406 976"> <tr> <td data-bbox="943 842 995 887">A</td> <td data-bbox="995 842 1406 887">Flat mark on the shaft</td> </tr> <tr> <td data-bbox="943 887 995 931">B</td> <td data-bbox="995 887 1406 931">Notch</td> </tr> <tr> <td data-bbox="943 931 995 976">C</td> <td data-bbox="995 931 1406 976">Calibration block</td> </tr> </table> <div data-bbox="943 994 1406 1272">  </div> <p data-bbox="943 1330 1050 1352">xx1500002224</p>	A	Flat mark on the shaft	B	Notch	C	Calibration block
A	Flat mark on the shaft							
B	Notch							
C	Calibration block							
3	<p>Secure with the screw.</p>	<div data-bbox="943 1377 1406 1608">  </div> <p data-bbox="943 1715 1050 1738">xx1500002222</p> <p data-bbox="943 1756 1225 1818">Screw: M5x8 (1 pcs) Tightening torque: 10 Nm</p> <div data-bbox="943 1832 1002 1890">  </div> <p data-bbox="1034 1850 1091 1872"><b>Note</b></p> <p data-bbox="943 1904 1406 1957">Only use specified screws, never replace them with other screws.</p>						

*Continues on next page*



Refitting the upper arm



**Note**

Two persons working together are required to perform this procedure.

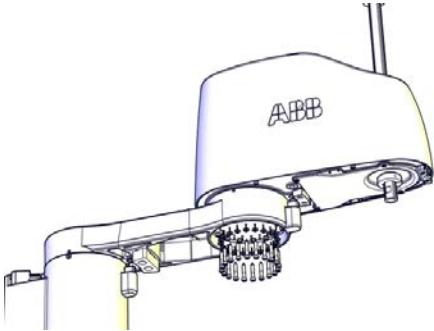
	Action	Note
1	 <b>Note</b> Two persons working together are required to perform this step. Person 1: Hold the upper arm. Person 2: Refit the screws that fasten the upper arm to the lower arm.	
2	Make sure the lower arm is secured. Lower the upper arm down onto the right place of the lower arm.	
3	Refit the upper arm screws and washers.	 <p>xx1500002256</p> <p>Screw: M4x20 (16 pcs)                      Tightening torque: 4.5 Nm                      Washer: 4.3x9x1.3 (16 pcs)</p>

Refitting the main cable to the upper arm

	Action	Note
1	Secure the main cable package with cable ties if needed.	

Continues on next page

## 4 Repair

### 4.4.1 Replacing the upper arm

Continued

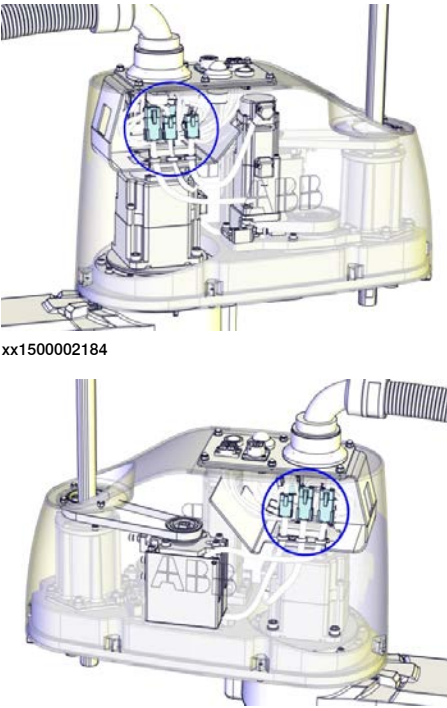
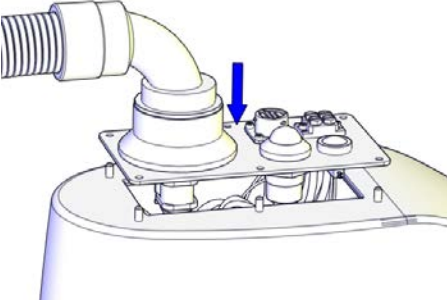
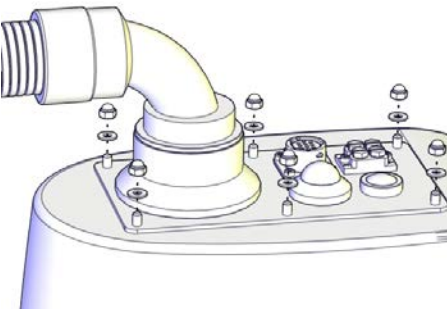
	Action	Note
2	<p>Reconnect the connectors.</p> <ul style="list-style-type: none"><li>• R2.MP2</li><li>• R2.MP3</li><li>• R2.MP4</li><li>• R2.ME2</li><li>• R2.ME3</li><li>• R2.ME4</li></ul>	 <p>Diagram illustrating the reconnection of connectors. The top image (xx1500002184) shows the upper arm assembly with a blue circle highlighting the connector area. The bottom image (xx1500002185) shows the same assembly from a different angle, also highlighting the connector area.</p>
3	<p>Push the main cable package into place.</p>	 <p>Diagram illustrating the main cable package being pushed into place. A blue arrow points to the cable package being inserted into the upper arm assembly.</p>
4	<p>Refit the user interface plate.</p>	 <p>Diagram illustrating the refitting of the user interface plate. The plate is shown being secured to the upper arm assembly with dome nuts and washers.</p> <p>xx1500002182</p> <p>Dome nut: M4 (6 pcs) Tightening torque: 2 Nm Washer, 6 pcs</p>

Continues on next page

#### Concluding procedure

	Action	Note
1	Recalibrate the robot.	Calibration is detailed in section <a href="#">Calibration on page 349</a> .
2	 <b>DANGER</b>  Make sure all safety requirements are met when performing the first test run. These are further detailed in the section "First test run may cause injury or damage" in <i>Safety manual for robot - Manipulator and IRC5 or OmniCore controller</i> .	

## 4 Repair

### 4.4.2 Replacing the ball screw spline unit

### 4.4.2 Replacing the ball screw spline unit

#### General



#### Note

If a collision with the stop blocks on the ball screw spline unit occur, check and retighten all screws before replacement work. Replace damaged or cracked screws.

#### Location of the ball screw spline unit

The ball screw spline unit is located as shown in the figure.

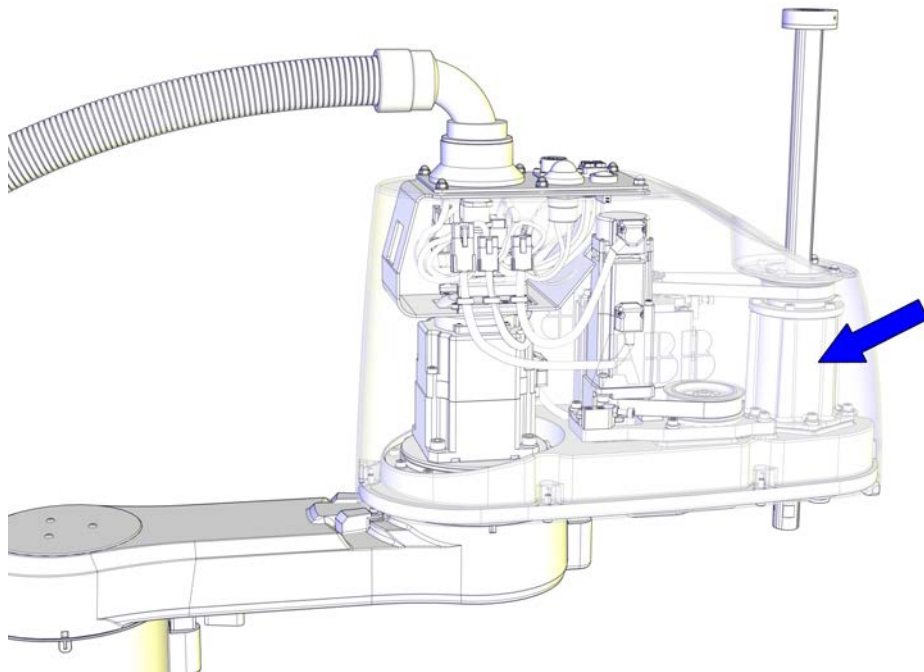

xx1500002212

#### Required spare parts



#### Note

The spare part numbers that are listed in the table can be out of date. See the latest spare parts of the IRB 910SC via myABB Business Portal, [www.abb.com/myABB](http://www.abb.com/myABB).

Spare part	Article number	Note
Ball screw spline unit	3HAC056148-001	

*Continues on next page*

**Required tools and equipment**

Equipment	Article number	Note
Standard toolkit	-	The content is defined in the section <a href="#">Standard toolkit on page 392</a> .
Sonic tensiometer	-	Used for measuring the timing belt tension.
Dynamometer	-	Used for measuring the timing belt tension.

**Required consumables**

Consumable	Article number	Note
Grease	-	THK AFA Used for lubricating the ball screw spline shaft.
Cable ties	-	

*Continues on next page*

## 4 Repair



### 4.4.2 Replacing the ball screw spline unit

*Continued*

#### Removing the ball screw spline unit

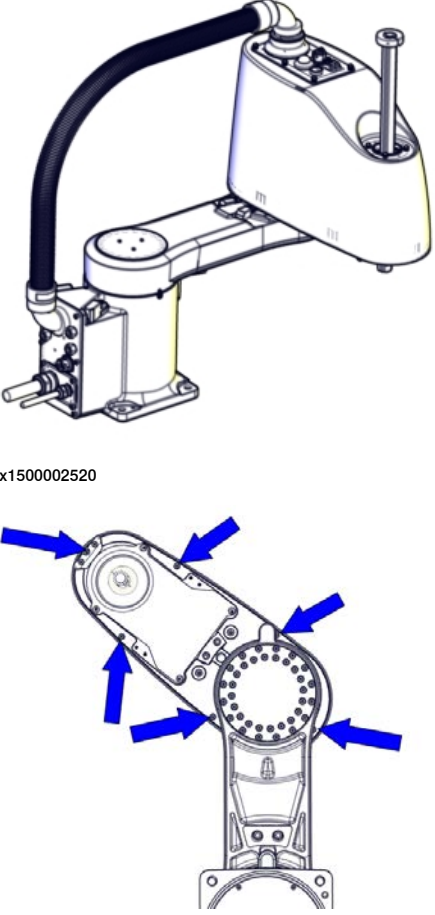

Use these procedures to remove the ball screw spline unit.

#### Preparations before removing the ball screw spline unit

	Action	Note
1	Jog axis 2 to access the cover screws.	 <p>xx1500002520</p> <p>xx1500002782</p>
2	 <b>DANGER</b> Turn off all: <ul style="list-style-type: none"><li>• electric power supply</li><li>• hydraulic pressure supply</li><li>• air pressure supply</li></ul> to the robot, before entering the robot working area.	

*Continues on next page*

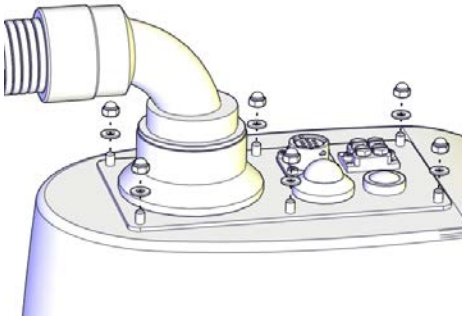
Removing the main cable package from the upper arm

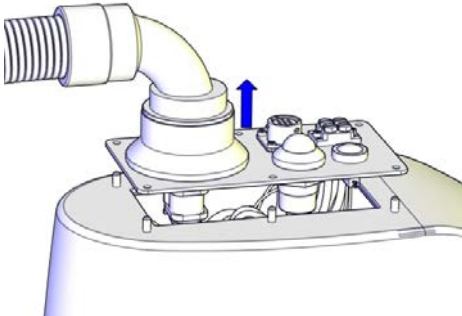
	Action	Note
1	<p> <b>DANGER</b></p> <p>Make sure that all supplies for electrical power, hydraulic pressure, and air pressure are turned off.</p>	
2	<p>Remove the dome nuts and washers.</p>	 <p>xx1500002182</p>
3	<p>Carefully open the user interface plate and pull out the cable package.</p> <p> <b>CAUTION</b></p> <p>The plate cannot be removed completely until the connectors are disconnected, as shown in the following step.</p>	 <p>xx1500002183</p>

Continues on next page



## 4 Repair

### 4.4.2 Replacing the ball screw spline unit

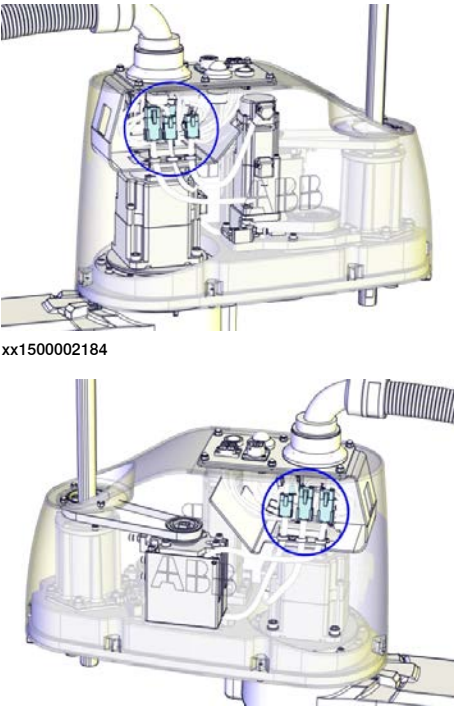
Continued

	Action	Note
4	<p>Disconnect the connectors:</p> <ul style="list-style-type: none"> <li>• R2.MP2</li> <li>• R2.MP3</li> <li>• R2.MP4</li> <li>• R2.ME2</li> <li>• R2.ME3</li> <li>• R2.ME4</li> </ul> <p> <b>Tip</b></p> <p>Take photos of the connectors and cable position before disconnecting them, to have as a reference when reconnecting.</p>	

### Removing the upper cover

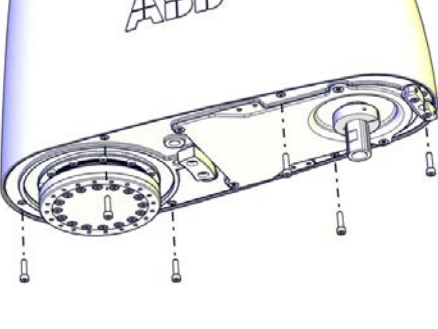
	Action	Note
1	<p> <b>DANGER</b></p> <p>Make sure that all supplies for electrical power, hydraulic pressure, and air pressure are turned off.</p>	
2	<p> <b>WARNING</b></p> <p>Risk of tipping. Make sure the robot is well secured and that the upper arm is supported during the removal work.</p>	
3	<p>Remove the screws.</p>	

Continues on next page

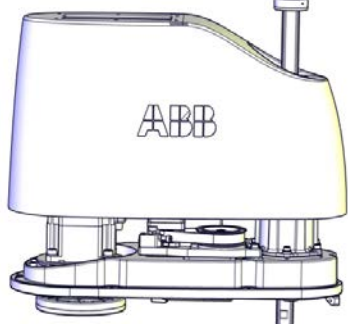

4.4.2 Replacing the ball screw spline unit  
Continued

	Action	Note
4	 <b>WARNING</b> The cover may be damaged due to improper shift. Keep the cover in position while removing the screws.	
5	Lift out the upper cover carefully.	 xx1500002221

Removing the lower stop block

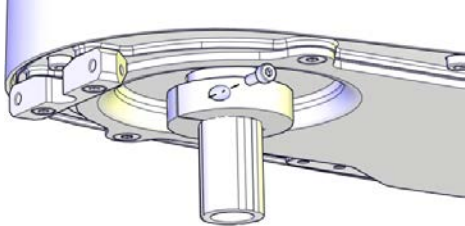
	Action	Note
1	 <b>DANGER</b> Make sure that all supplies for electrical power, hydraulic pressure, and air pressure are turned off.	
2	Remove the lower stop block of ball screw spline unit to replace: <ul style="list-style-type: none"> <li>• lower cover of the upper arm</li> <li>• ball screw spine unit</li> <li>• upper arm body</li> </ul>	
3	Remove the screws.	 xx1500002222

Continues on next page



## 4 Repair

### 4.4.2 Replacing the ball screw spline unit

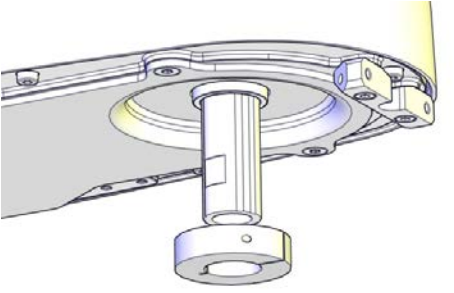
Continued

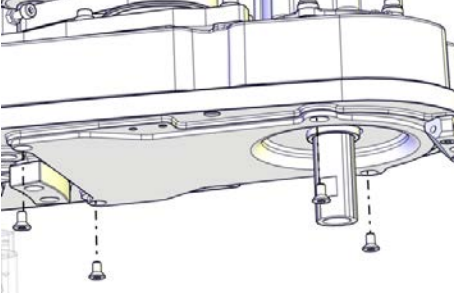

	Action	Note
4	Remove the stop block.	 <p>xx1500002223</p>

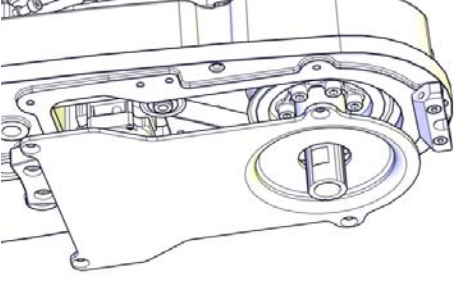
### Removing the lower cover



	Action	Note
1	 <p><b>DANGER</b></p> <p>Make sure that all supplies for electrical power, hydraulic pressure, and air pressure are turned off.</p>	
2	Remove the screws.	 <p>xx1500002785</p>
3	<p>Remove the cover.</p>  <p><b>Tip</b></p> <p>If only working with lower axis-4 timing belt, no need to remove the stop block of ball screw spline unit before removing the lower cover.</p>	 <p>xx1500002225</p>

Continues on next page

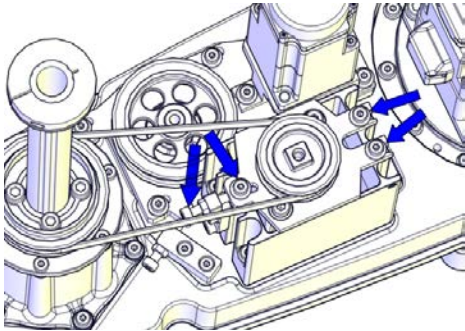
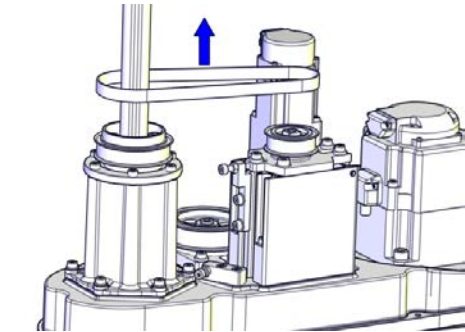
Removing the axis-3 timing belt

	Action	Note
1	 <b>DANGER</b> Make sure that all supplies for electrical power, hydraulic pressure, and air pressure are turned off.	
2	 <b>WARNING</b> Risk of tipping. Make sure the gravity center is well supported.	
3	Loosen the screws and move the axis-3 drive unit upwards to slacken the timing belt.	 <p>xx1500002229</p>
4	Remove the timing belt.	 <p>xx1500002230</p>

Removing the lower axis-4 timing belt

	Action	Note
1	 <b>DANGER</b> Make sure that all supplies for electrical power, hydraulic pressure, and air pressure are turned off.	
2	 <b>WARNING</b> Risk of tipping. Make sure the gravity center is well supported.	

Continues on next page

## 4 Repair

### 4.4.2 Replacing the ball screw spline unit

Continued

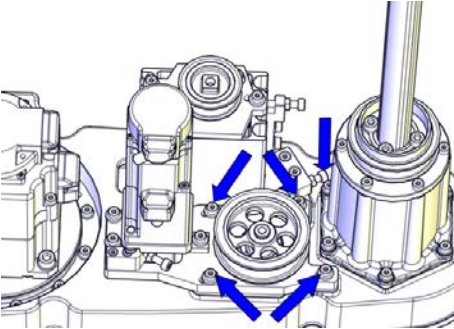
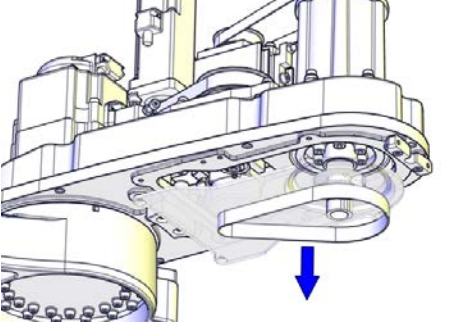
	Action	Note
3	Loosen the screws and move the axis-4 housing sideways to slacken the lower axis-4 timing belt.	 <p>xx1500002231</p>
4	Remove the timing belt.	 <p>xx1500002232</p>

### Removing the ball screw spline

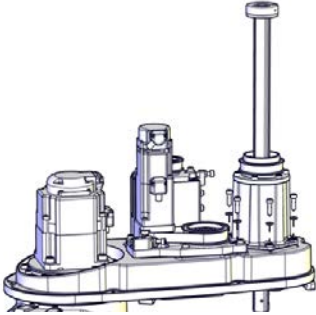
	Action	Note
1	 <p><b>DANGER</b></p> <p>Make sure that all supplies for electrical power, hydraulic pressure, and air pressure are turned off.</p>	
2	Remove the screws.	 <p>xx1500002788</p>

Continues on next page

4.4.2 Replacing the ball screw spline unit  
Continued

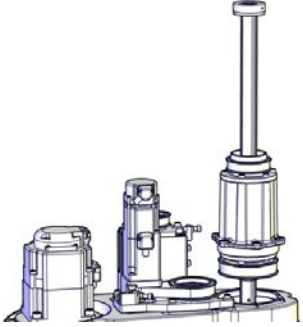
	Action	Note
3	Remove the ball screw spline unit.	 <p>xx1500002787</p>

**Refitting the ball screw spline unit**

Use these procedures to refit the ball screw spline unit.

Refitting the ball screw spline unit

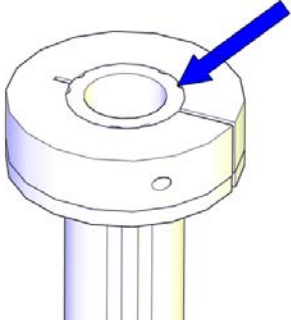
	Action	Note
1	Make sure that: <ul style="list-style-type: none"> <li>all assembly surfaces are clean and undamaged.</li> <li>the ball screw spline unit is well-lubricated and undamaged.</li> </ul>	See <a href="#">Lubricating the ball screw spline unit on page 113</a> .
2	If a new ball screw spline unit is used, remove the lower stop block to enable fitting of the lower cover.	See "Removing the lower stop block" in <a href="#">Removing the ball screw spline unit on page 234</a> .
3	Check the upper stop block of the ball screw spline unit. Replace if damaged. Make sure the upper surfaces of the shaft and stop block are at the same level.	Upper axis-3 and axis-4 mechanical stop block: 3HAC061259-001  <p>xx1600002115</p>

Continues on next page

## 4 Repair

### 4.4.2 Replacing the ball screw spline unit

Continued

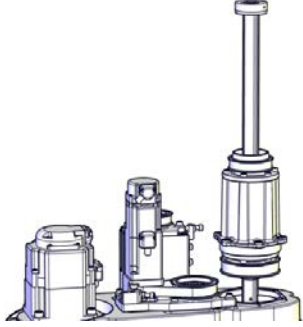
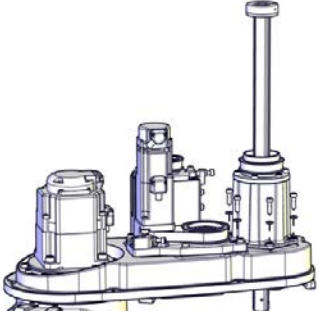
	Action	Note
4	Refit the ball screw spline unit.	Ball screw spline unit: 3HAC056148-001  xx1500002787
5	Secure with screws and washers.	 xx1500002788 Screw: M4x16 (6 pcs) Tightening torque: 4.5 Nm Washer: M4 (6 pcs)

### Refitting the lower axis-4 timing belt

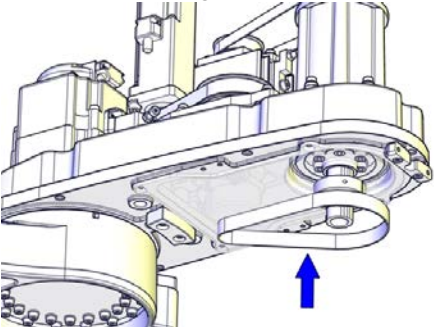
	Action	Note
1	Make sure that: <ul style="list-style-type: none"> <li>• all assembly surfaces are clean and undamaged.</li> <li>• the drive unit is clean and undamaged.</li> </ul>	
2	Refit lower axis-4 timing belt. Ensure that the belt runs correctly in the grooves.	Lower axis-4 timing belt: 3HAC055201-001  xx1500002786

Continues on next page

4.4.2 Replacing the ball screw spline unit  
Continued

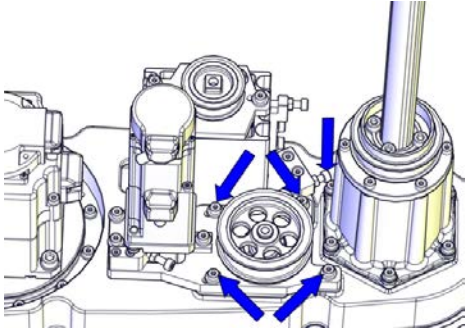
	Action	Note
3	Fasten the screws little by little while using a dynamometer to measure the belt tension until a proper belt tension is achieved.	 <p data-bbox="970 645 1077 667">xx1500002231</p> <p data-bbox="970 680 1422 712">Belt tension: <math>F = 101 \text{ N}</math> (Recommended)</p> <p data-bbox="970 716 1182 748">Belt tension range:</p> <p data-bbox="970 752 1437 831">64.5 N to 73.7 N (for used timing belt, which has been installed and used for more than 24 hours)</p> <p data-bbox="970 835 1374 866">92.2 N to 101 N (for new timing belt)</p>

Refitting the axis-3 timing belt

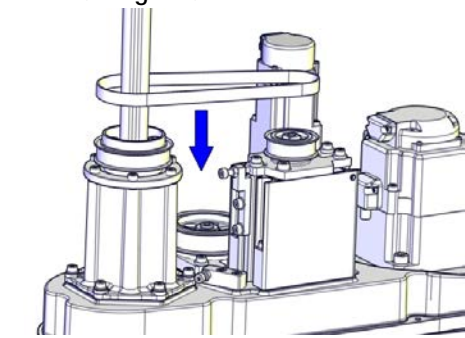
	Action	Note
1	Make sure that: <ul style="list-style-type: none"> <li>• all assembly surfaces are clean and undamaged.</li> <li>• the drive unit is clean and undamaged.</li> </ul>	
2	Refit axis-3 timing belt. Ensure that the belt runs correctly in the grooves.	Axis-3 timing belt: 3HAC055209-001  <p data-bbox="970 1518 1077 1541">xx1500002789</p>

Continues on next page



## 4 Repair

### 4.4.2 Replacing the ball screw spline unit

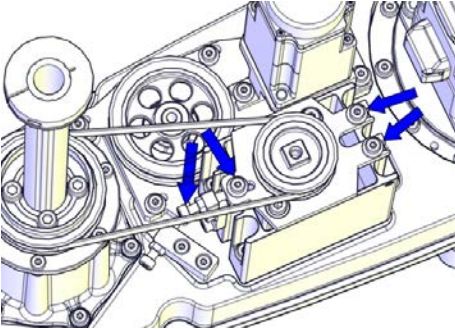
Continued

	Action	Note
3	Fasten the screws little by little while using a dynamometer to measure the belt tension until a proper belt tension is achieved.	 <p data-bbox="943 645 1050 663">xx150002229</p> <p data-bbox="943 680 1374 707">Belt tension: <math>F = 34 \text{ N}</math> (Recommended)</p> <p data-bbox="943 714 1155 741">Belt tension range:</p> <p data-bbox="943 748 1406 831">21.8 N to 24.9 N (for used timing belt, which has been installed and used for more than 24 hours)</p> <p data-bbox="943 837 1326 864">31.1 to 34.2 N (for new timing belt)</p>

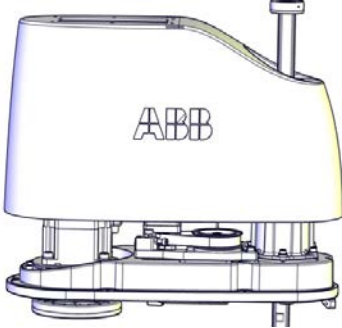
### Refitting the upper cover

	Action	Note
1	Carefully put down the upper cover, avoiding any collision to the ball screw spline unit and drive units.	<p data-bbox="943 996 1334 1023">Upper cover unit: 3HAC057615-001</p>  <p data-bbox="943 1361 1050 1379">xx150002221</p>
2	 <b>Tip</b> Some of the screws are accessed from below. Make sure that the robot is properly fastened and hang out the upper arm from the workbench to access them.	

Continues on next page

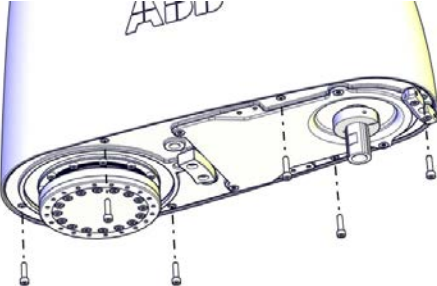

4.4.2 Replacing the ball screw spline unit  
Continued

	Action	Note
3	Refit the cover.	 <p data-bbox="973 645 1077 667">xx150002220</p> <p data-bbox="973 683 1212 705">Screw: M4x16 (6 pcs)</p> <p data-bbox="973 716 1236 739">Tightening torque: 2 Nm</p>

Refitting the lower cover

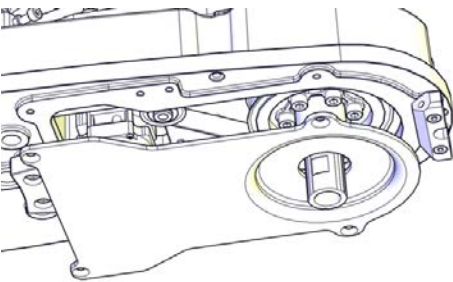
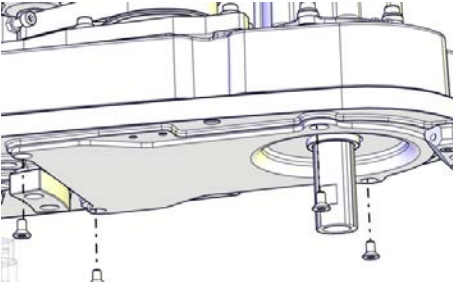
	Action	Note
1	Refit the cover.	 <p data-bbox="973 873 1316 896">Lower cover: 3HAC060106-001</p> <p data-bbox="973 1232 1077 1254">xx150002225</p>
2	Secure with screws.	 <p data-bbox="973 1624 1077 1646">xx150002785</p> <p data-bbox="973 1657 1197 1680">Screw: M4x8 (4 pcs)</p> <p data-bbox="973 1691 1236 1713">Tightening torque: 2 Nm</p>

Refitting the lower stop block



	Action	Note
1	Check the lower stop block of the ball screw spline unit. Replace if damaged.	Lower axis-3 and axis-4 mechanical stop block: 3HAC055208-001

Continues on next page

## 4 Repair

### 4.4.2 Replacing the ball screw spline unit

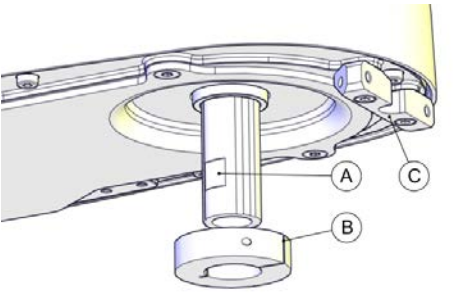
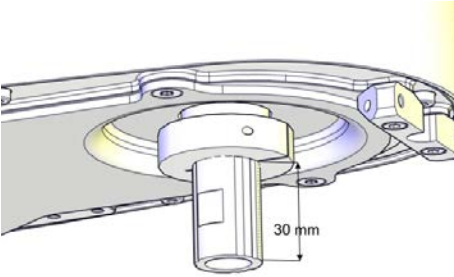
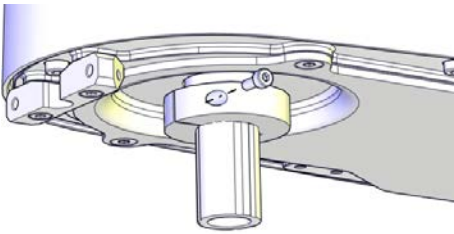
Continued

	Action	Note						
2	<p>Refit the lower stop block.</p> <p>Make the notch point to the calibration block and 90° away from the flat mark on the shaft.</p> <p>Make sure the distance between the lower surfaces of stop block and shaft is 30 mm.</p>	 <p>xx1500002908</p> <table border="1" data-bbox="943 680 1398 819"> <tr> <td>A</td> <td>Flat mark on the shaft</td> </tr> <tr> <td>B</td> <td>Notch</td> </tr> <tr> <td>C</td> <td>Calibration block</td> </tr> </table>  <p>xx1500002224</p>	A	Flat mark on the shaft	B	Notch	C	Calibration block
A	Flat mark on the shaft							
B	Notch							
C	Calibration block							
3	Secure with the screw.	 <p>xx1500002222</p> <p>Screw: M5x8 (1 pcs) Tightening torque: 10 Nm</p> <p> <b>Note</b></p> <p>Only use specified screws, never replace them with other screws.</p>						

### Refitting the main cable to the upper arm

	Action	Note
1	Secure the main cable package with cable ties if needed.	

Continues on next page

4.4.2 Replacing the ball screw spline unit  
Continued

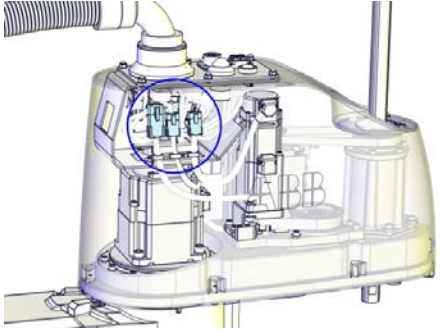
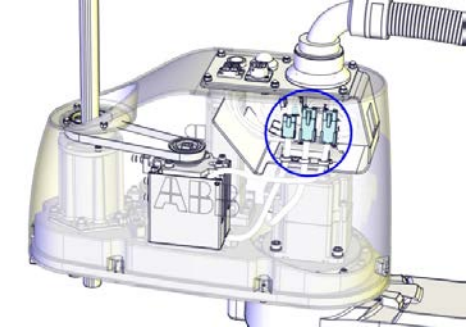
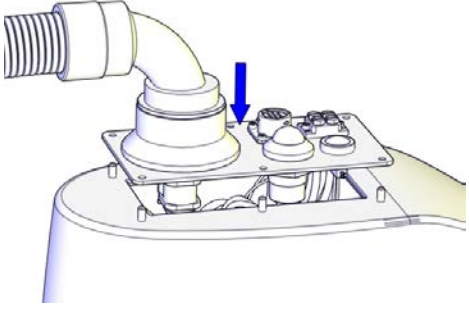
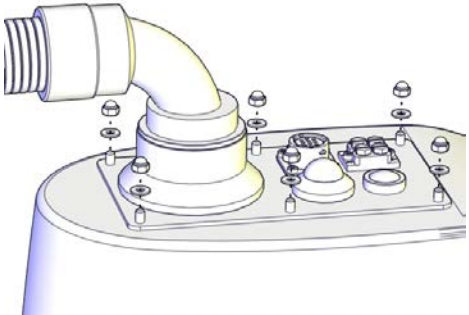
	Action	Note
2	<p>Reconnect the connectors.</p> <ul style="list-style-type: none"> <li>• R2.MP2</li> <li>• R2.MP3</li> <li>• R2.MP4</li> <li>• R2.ME2</li> <li>• R2.ME3</li> <li>• R2.ME4</li> </ul>	 <p>xx1500002184</p>  <p>xx1500002185</p>
3	<p>Push the main cable package into place.</p>	 <p>xx1500002207</p>
4	<p>Refit the user interface plate.</p>	 <p>xx1500002182</p> <p>Dome nut: M4 (6 pcs) Tightening torque: 2 Nm Washer, 6 pcs</p>

Continues on next page

## 4 Repair

---

### 4.4.2 Replacing the ball screw spline unit

*Continued*

Concluding procedure

	Action	Note
1	Recalibrate the robot.	Calibration is detailed in section <a href="#">Calibration on page 349</a> .
2	 <b>DANGER</b> Make sure all safety requirements are met when performing the first test run. These are further detailed in the section "First test run may cause injury or damage" in <i>Safety manual for robot - Manipulator and IRC5 or OmniCore controller</i> .	

### 4.4.3 Replacing the axis-3 timing belt

#### Location of the axis-3 timing belt

The axis-3 timing belt is located as shown in the figure.

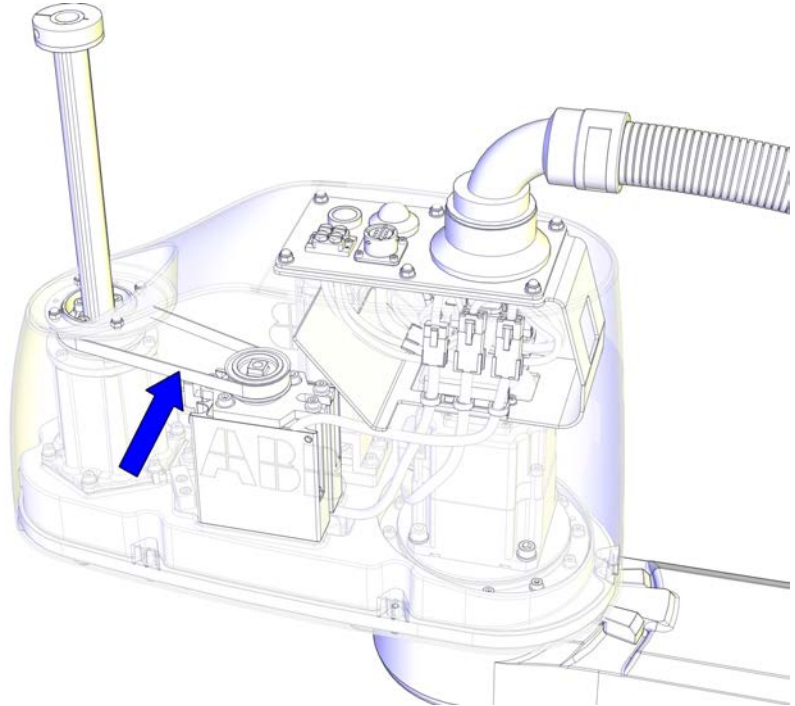

xx1500002218

#### Required spare parts



#### Note

The spare part numbers that are listed in the table can be out of date. See the latest spare parts of the IRB 910SC via myABB Business Portal, [www.abb.com/myABB](http://www.abb.com/myABB).

Spare part	Article number	Note
Axis-3 timing belt	3HAC055209-001	
Upper cover unit	3HAC057615-001	Includes upper cover and cover flange.

#### Required tools and equipment



#### Note

The spare part numbers that are listed in the table can be out of date. See the latest revision of *Product manual, spare parts - IRB 910SC* on ABB Library.

*Continues on next page*

## 4 Repair

### 4.4.3 Replacing the axis-3 timing belt

*Continued*

Equipment	Article number	Note
Standard toolkit	-	The content is defined in the section <a href="#">Standard toolkit on page 392</a> .
Sonic tensiometer	-	Used for measuring the timing belt tension.
Dynamometer	-	Used for measuring the timing belt tension.

#### Required consumables

Consumable	Article number	Note
Cable ties	-	

#### Removing the axis-3 timing belt

Use these procedures to remove the axis-3 timing belt.

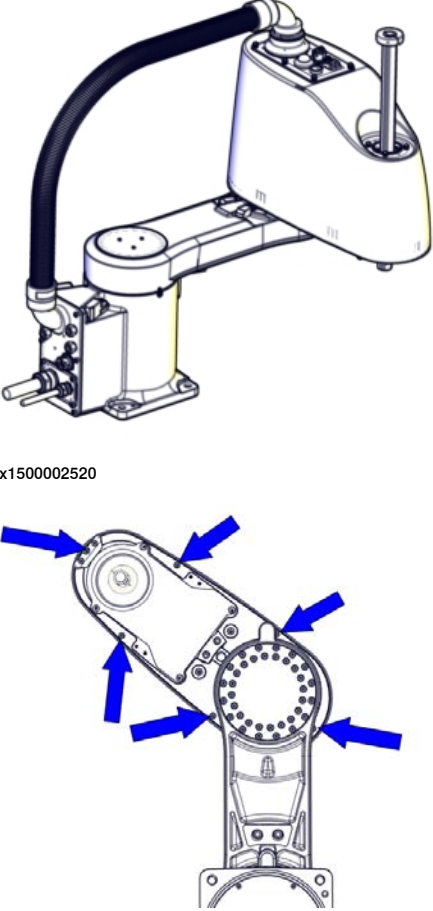

#### Preparations before removing the axis-3 timing belt

Action	Note
1 Jog axis 2 to access the cover screws.	 <p>xx1500002520</p> <p>xx1500002782</p>

*Continues on next page*

	Action	Note
2	<p> <b>DANGER</b></p> <p>Turn off all:</p> <ul style="list-style-type: none"> <li>• electric power supply</li> <li>• hydraulic pressure supply</li> <li>• air pressure supply</li> </ul> <p>to the robot, before entering the robot working area.</p>	

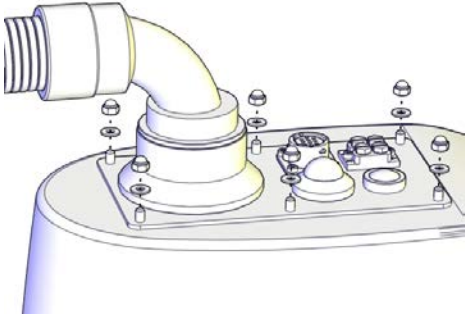
Removing the main cable package from the upper arm

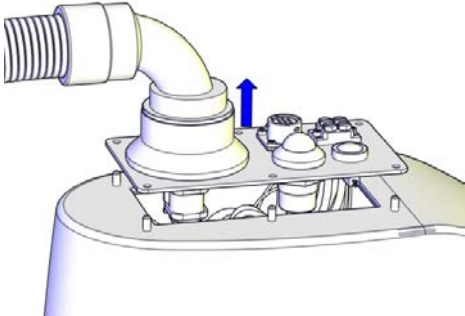
	Action	Note
1	<p> <b>DANGER</b></p> <p>Make sure that all supplies for electrical power, hydraulic pressure, and air pressure are turned off.</p>	
2	<p>Remove the dome nuts and washers.</p>	 <p>xx1500002182</p>
3	<p>Carefully open the user interface plate and pull out the cable package.</p> <p> <b>CAUTION</b></p> <p>The plate cannot be removed completely until the connectors are disconnected, as shown in the following step.</p>	 <p>xx1500002183</p>

Continues on next page



## 4 Repair

### 4.4.3 Replacing the axis-3 timing belt

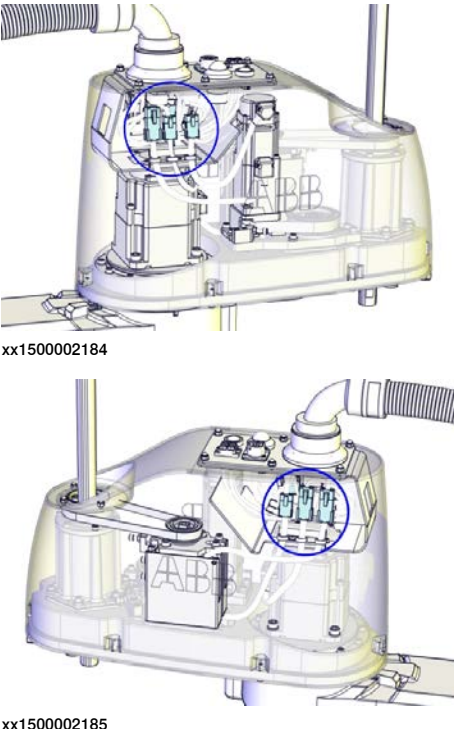
Continued

	Action	Note
4	<p>Disconnect the connectors:</p> <ul style="list-style-type: none"> <li>• R2.MP2</li> <li>• R2.MP3</li> <li>• R2.MP4</li> <li>• R2.ME2</li> <li>• R2.ME3</li> <li>• R2.ME4</li> </ul> <p> <b>Tip</b></p> <p>Take photos of the connectors and cable position before disconnecting them, to have as a reference when reconnecting.</p>	

### Removing the upper cover

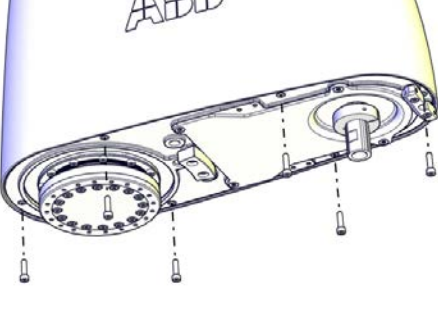

	Action	Note
1	<p> <b>DANGER</b></p> <p>Make sure that all supplies for electrical power, hydraulic pressure, and air pressure are turned off.</p>	
2	<p> <b>WARNING</b></p> <p>Risk of tipping. Make sure the robot is well secured and that the upper arm is supported during the removal work.</p>	
3	<p>Remove the screws.</p>	

Continues on next page

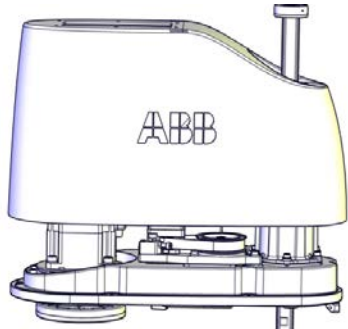

	Action	Note
4	 <p><b>WARNING</b></p> <p>The cover may be damaged due to improper shift. Keep the cover in position while removing the screws.</p>	
5	<p>Lift out the upper cover carefully.</p>	 <p>xx1500002221</p>

Removing the drive unit cables

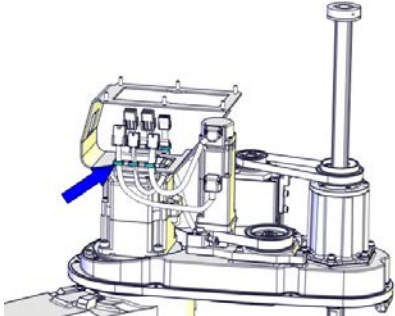
	Action	Note
1	 <p><b>DANGER</b></p> <p>Make sure that all supplies for electrical power, hydraulic pressure, and air pressure are turned off.</p>	
2	<p>Cut the cable ties. Be careful not to damage the cabling.</p>  <p><b>Tip</b></p> <p>Take photos of the cable position before removing them, to have as a reference when refitting.</p>	 <p>xx1500002226</p>

Removing the axis-3 timing belt

	Action	Note
1	 <p><b>DANGER</b></p> <p>Make sure that all supplies for electrical power, hydraulic pressure, and air pressure are turned off.</p>	

Continues on next page

## 4 Repair

### 4.4.3 Replacing the axis-3 timing belt

*Continued*

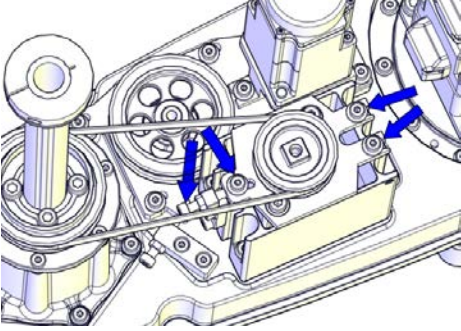
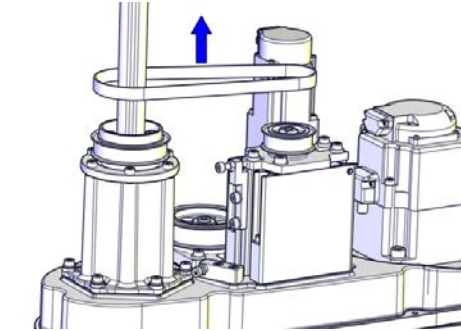
	Action	Note
2	 <b>WARNING</b> Risk of tipping. Make sure the gravity center is well supported.	
3	Loosen the screws and move the axis-3 drive unit upwards to slacken the timing belt.	 <p>xx1500002229</p>
4	Remove the timing belt.	 <p>xx1500002230</p>

#### Refitting the axis-3 timing belt

Use these procedures to refit the axis-3 timing belt.

#### Refitting the axis-3 timing belt

	Action	Note
1	Make sure that: <ul style="list-style-type: none"> <li>• all assembly surfaces are clean and undamaged.</li> <li>• the drive unit is clean and undamaged.</li> </ul>	

*Continues on next page*

### 4.4.3 Replacing the axis-3 timing belt

*Continued*

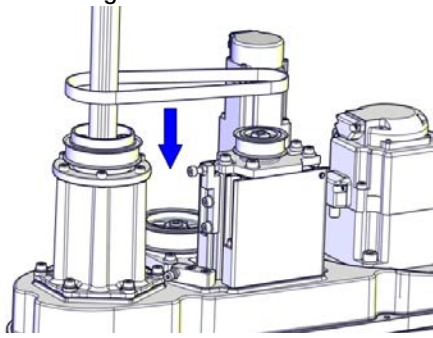
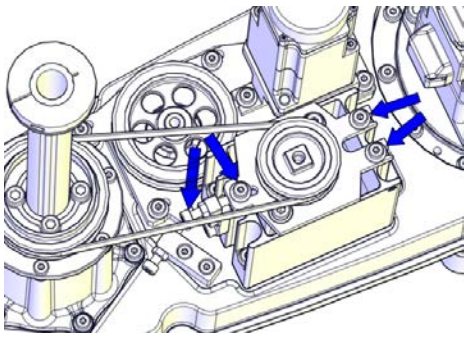
	Action	Note
2	Refit axis-3 timing belt. Ensure that the belt runs correctly in the grooves.	<p>Axis-3 timing belt: 3HAC055209-001</p>  <p>xx1500002789</p>
3	Fasten the screws little by little while using a dynamometer to measure the belt tension until a proper belt tension is achieved.	 <p>xx1500002229</p> <p>Belt tension: <math>F = 34 \text{ N}</math> (Recommended)            Belt tension range:            21.8 N to 24.9 N (for used timing belt, which has been installed and used for more than 24 hours)            31.1 to 34.2 N (for new timing belt)</p>

*Continues on next page*

## 4 Repair

### 4.4.3 Replacing the axis-3 timing belt

*Continued*

#### Securing the drive unit cables

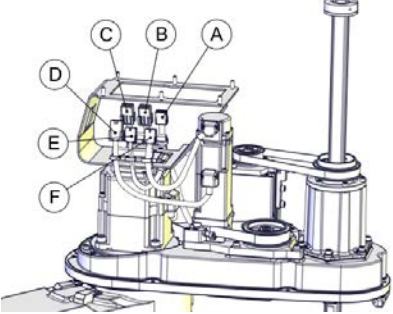
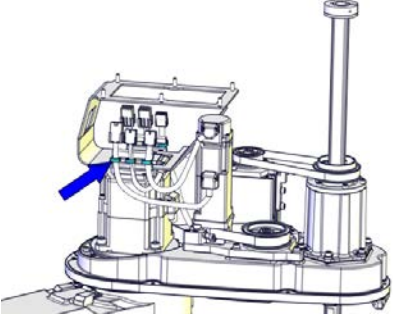
	Action	Note												
1	Put the drive unit cables in place.	 <p data-bbox="943 696 1050 719">xx1500003063</p> <table border="1" data-bbox="943 734 1406 1010"> <tbody> <tr> <td data-bbox="943 734 995 779">A</td> <td data-bbox="995 734 1406 779">R2.ME3</td> </tr> <tr> <td data-bbox="943 779 995 824">B</td> <td data-bbox="995 779 1406 824">R2.MP2</td> </tr> <tr> <td data-bbox="943 824 995 869">C</td> <td data-bbox="995 824 1406 869">R2.MP3</td> </tr> <tr> <td data-bbox="943 869 995 913">D</td> <td data-bbox="995 869 1406 913">R2.MP4</td> </tr> <tr> <td data-bbox="943 913 995 958">E</td> <td data-bbox="995 913 1406 958">R2.ME2</td> </tr> <tr> <td data-bbox="943 958 995 1010">F</td> <td data-bbox="995 958 1406 1010">R2. ME4</td> </tr> </tbody> </table>	A	R2.ME3	B	R2.MP2	C	R2.MP3	D	R2.MP4	E	R2.ME2	F	R2. ME4
A	R2.ME3													
B	R2.MP2													
C	R2.MP3													
D	R2.MP4													
E	R2.ME2													
F	R2. ME4													
2	Secure the cables with cable ties. Do not tighten the ties too tight.	 <p data-bbox="943 1368 1050 1391">xx1500002226</p>												

#### Refitting the upper cover

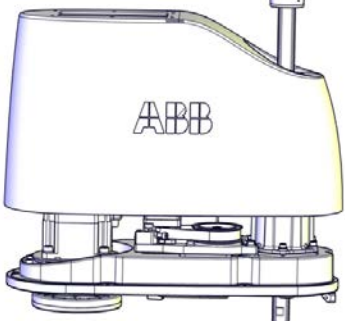
	Action	Note
1	Carefully put down the upper cover, avoiding any collision to the ball screw spline unit and drive units.	<p data-bbox="943 1541 1337 1570">Upper cover unit: 3HAC057615-001</p>  <p data-bbox="943 1906 1050 1928">xx1500002221</p>

*Continues on next page*

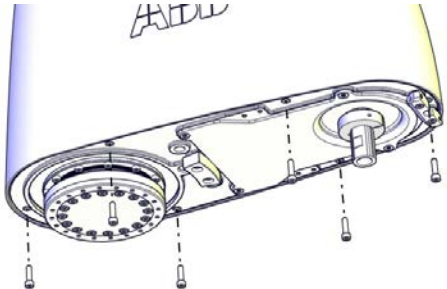
	Action	Note
2	 <b>Tip</b> Some of the screws are accessed from below. Make sure that the robot is properly fastened and hang out the upper arm from the workbench to access them.	
3	Refit the cover.	 <p data-bbox="976 882 1082 898">xx1500002220</p> <p data-bbox="976 920 1214 947">Screw: M4x16 (6 pcs)</p> <p data-bbox="976 954 1241 981">Tightening torque: 2 Nm</p>

Refitting the main cable to the upper arm

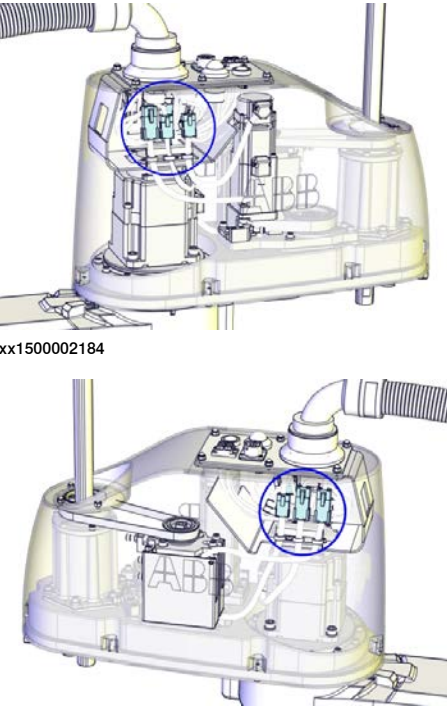
	Action	Note
1	Secure the main cable package with cable ties if needed.	
2	Reconnect the connectors. <ul style="list-style-type: none"> <li>• R2.MP2</li> <li>• R2.MP3</li> <li>• R2.MP4</li> <li>• R2.ME2</li> <li>• R2.ME3</li> <li>• R2.ME4</li> </ul>	 <p data-bbox="976 1514 1082 1529">xx1500002184</p> <p data-bbox="976 1888 1082 1904">xx1500002185</p>

Continues on next page

## 4 Repair

### 4.4.3 Replacing the axis-3 timing belt

Continued

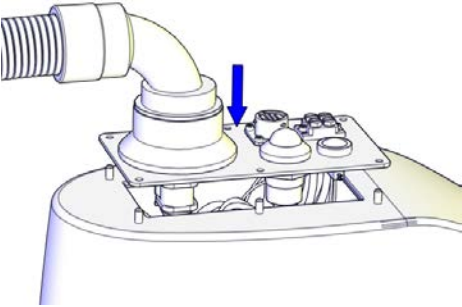
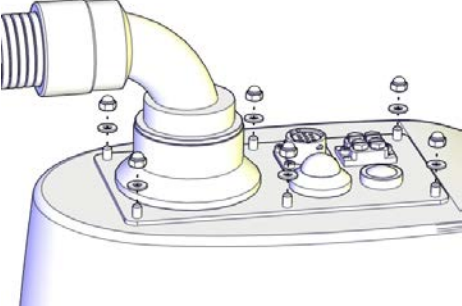
	Action	Note
3	Push the main cable package into place.	 <p>xx1500002207</p>
4	Refit the user interface plate.	 <p>xx1500002182</p> <p>Dome nut: M4 (6 pcs) Tightening torque: 2 Nm Washer, 6 pcs</p>

#### Concluding procedure

	Action	Note
1	Recalibrate the robot.	Calibration is detailed in section <a href="#">Calibration on page 349</a> .
2	 <p><b>DANGER</b></p> <p>Make sure all safety requirements are met when performing the first test run. These are further detailed in the section "First test run may cause injury or damage" in <i>Safety manual for robot - Manipulator and IRC5 or OmniCore controller</i>.</p>	

### 4.4.4 Replacing the axis-4 timing belts

#### Location of the axis-4 timing belts

The axis-4 timing belts are located as shown in the figures.

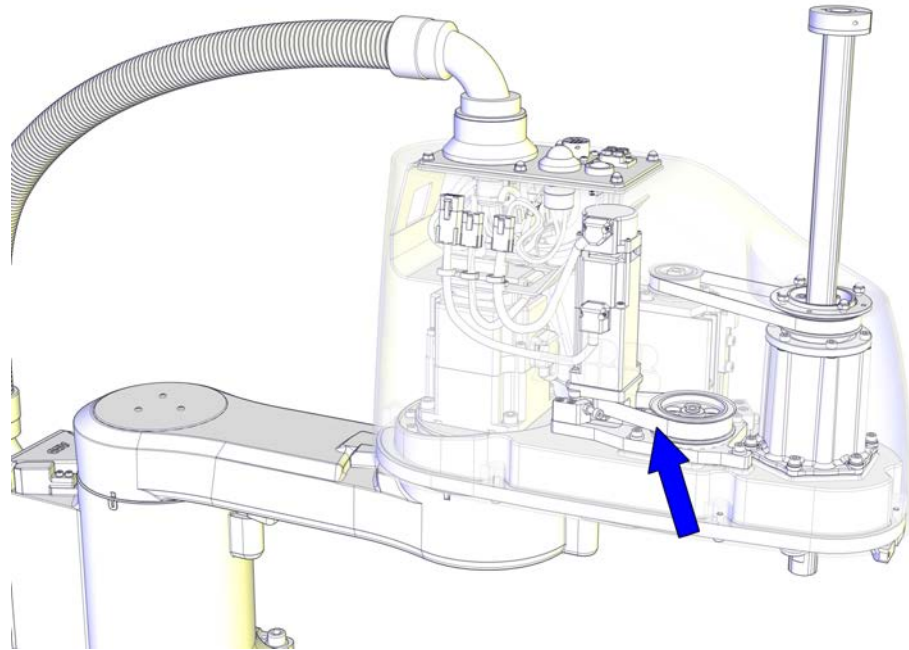

xx1500002216

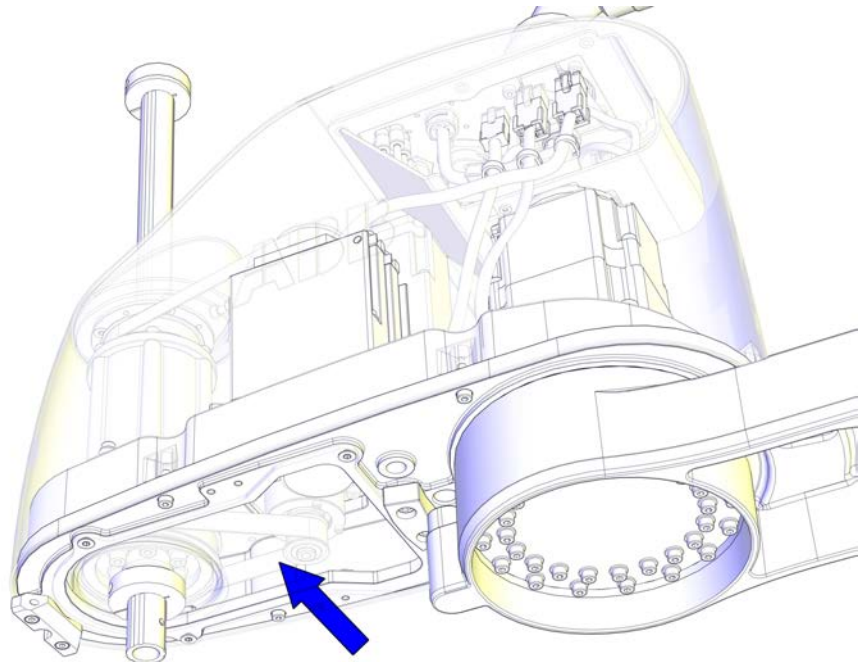

xx1500002217

*Continues on next page*



## 4 Repair

### 4.4.4 Replacing the axis-4 timing belts

Continued

#### Required spare parts



#### Note

The spare part numbers that are listed in the table can be out of date. See the latest spare parts of the IRB 910SC via myABB Business Portal, [www.abb.com/myABB](http://www.abb.com/myABB).

Spare part	Article number	Note
Upper axis-4 timing belt	3HAC055206-001	
Lower axis-4 timing belt	3HAC055201-001	
Upper cover unit	3HAC057615-001	Includes upper cover and cover flange.
Plain washer	3HAC056937-001	Replace if damaged.

#### Required tools and equipment



#### Note

The spare part numbers that are listed in the table can be out of date. See the latest revision of *Product manual, spare parts - IRB 910SC* on ABB Library.

Equipment	Article number	Note
Standard toolkit	-	The content is defined in the section <a href="#">Standard toolkit on page 392</a> .
Sonic tensiometer	-	Used for measuring the timing belt tension.
Dynamometer	-	Used for measuring the timing belt tension.

#### Required consumables

Consumable	Article number	Note
Cable ties	-	



Continues on next page



**Removing the axis-4 timing belts**

Use these procedures to remove the axis-4 timing belts.

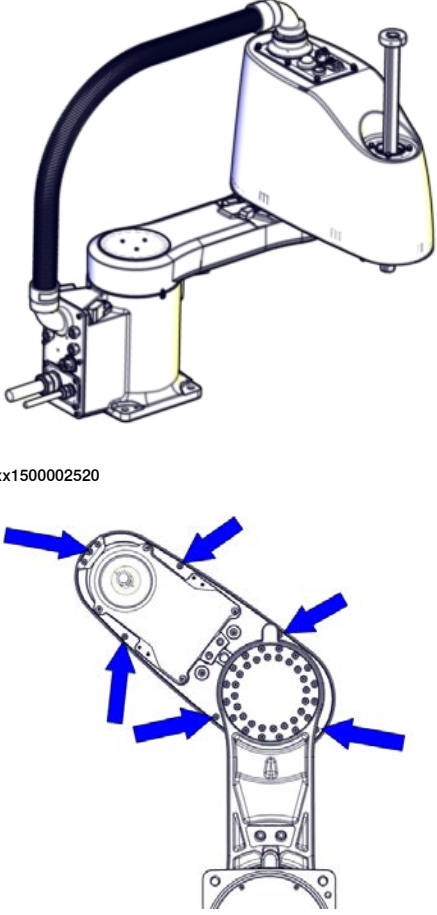
**Preparations before removing the axis-4 timing belts**

	Action	Note
1	Jog axis 2 to access the cover screws.	 <p>xx1500002520</p> <p>xx1500002782</p>
2	 <p><b>DANGER</b></p> <p>Turn off all:</p> <ul style="list-style-type: none"> <li>• electric power supply</li> <li>• hydraulic pressure supply</li> <li>• air pressure supply</li> </ul> <p>to the robot, before entering the robot working area.</p>	



Continues on next page

## 4 Repair

### 4.4.4 Replacing the axis-4 timing belts

*Continued*

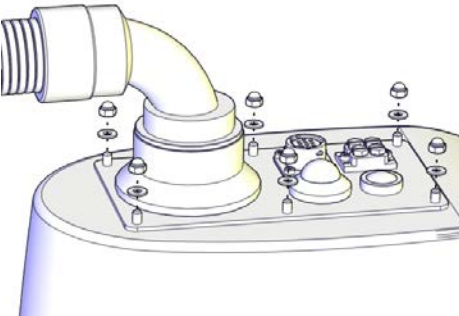

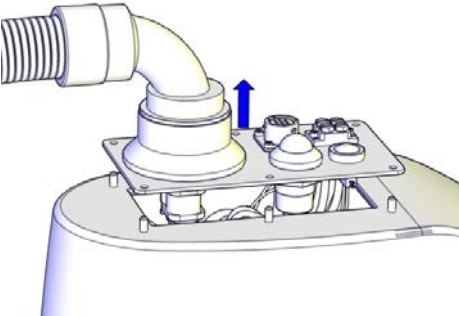
Removing the main cable package from the upper arm

	Action	Note
1	<p> <b>DANGER</b></p> <p>Make sure that all supplies for electrical power, hydraulic pressure, and air pressure are turned off.</p>	
2	Remove the dome nuts and washers.	 <p>xx1500002182</p>
3	<p>Carefully open the user interface plate and pull out the cable package.</p> <p> <b>CAUTION</b></p> <p>The plate cannot be removed completely until the connectors are disconnected, as shown in the following step.</p>	 <p>xx1500002183</p>

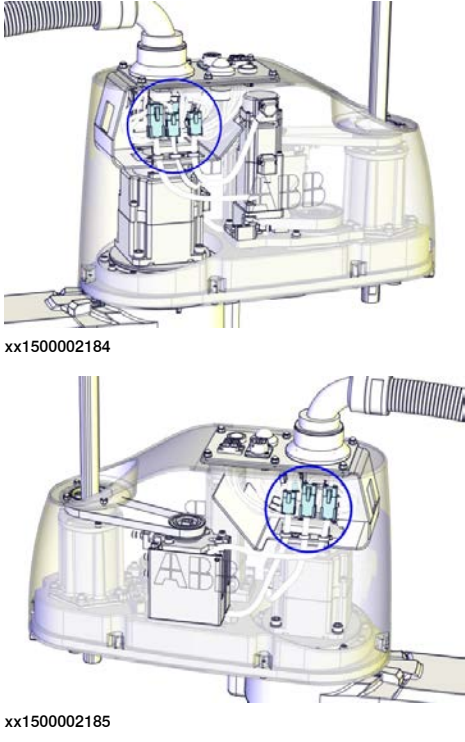
*Continues on next page*

	Action	Note
4	<p>Disconnect the connectors:</p> <ul style="list-style-type: none"> <li>• R2.MP2</li> <li>• R2.MP3</li> <li>• R2.MP4</li> <li>• R2.ME2</li> <li>• R2.ME3</li> <li>• R2.ME4</li> </ul> <p> <b>Tip</b></p> <p>Take photos of the connectors and cable position before disconnecting them, to have as a reference when reconnecting.</p>	

Removing the upper cover

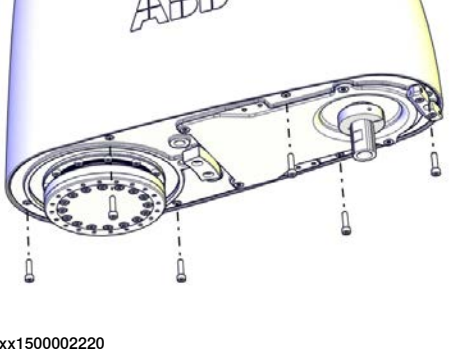
	Action	Note
1	<p> <b>DANGER</b></p> <p>Make sure that all supplies for electrical power, hydraulic pressure, and air pressure are turned off.</p>	
2	<p> <b>WARNING</b></p> <p>Risk of tipping. Make sure the robot is well secured and that the upper arm is supported during the removal work.</p>	
3	<p>Remove the screws.</p>	

Continues on next page



## 4 Repair

### 4.4.4 Replacing the axis-4 timing belts

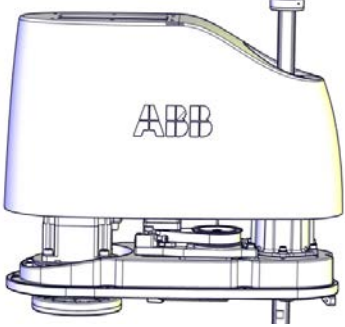
Continued

	Action	Note
4	 <b>WARNING</b> The cover may be damaged due to improper shift. Keep the cover in position while removing the screws.	
5	Lift out the upper cover carefully.	 <small>xx1500002221</small>

### Removing the drive unit cables

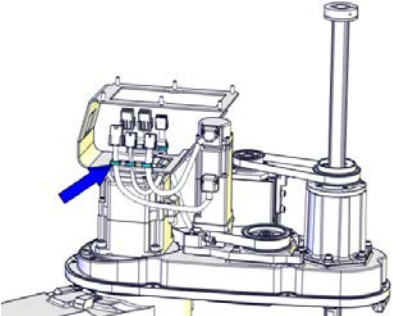

	Action	Note
1	 <b>DANGER</b> Make sure that all supplies for electrical power, hydraulic pressure, and air pressure are turned off.	
2	Cut the cable ties. Be careful not to damage the cabling.   <b>Tip</b> Take photos of the cable position before removing them, to have as a reference when refitting.	 <small>xx1500002226</small>

### Removing the lower cover

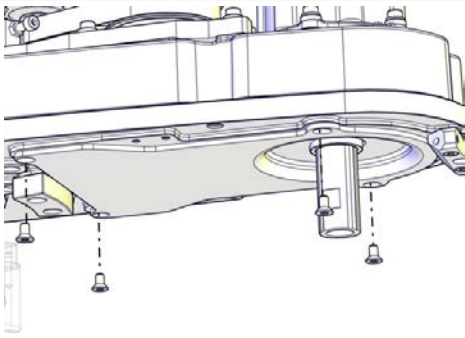

	Action	Note
1	 <b>DANGER</b> Make sure that all supplies for electrical power, hydraulic pressure, and air pressure are turned off.	

Continues on next page

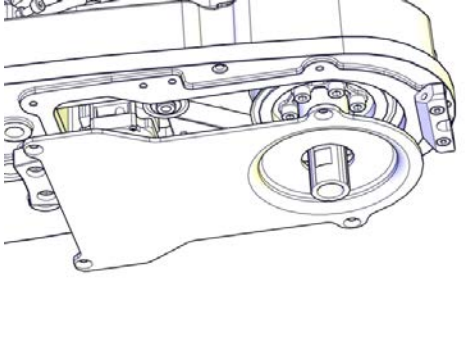
4.4.4 Replacing the axis-4 timing belts  
Continued

	Action	Note
2	Remove the screws.	 <p>xx1500002785</p>
3	Remove the cover.   <b>Tip</b>  If only working with lower axis-4 timing belt, no need to remove the stop block of ball screw spline unit before removing the lower cover.	 <p>xx1500002225</p>

Removing the lower axis-4 timing belt

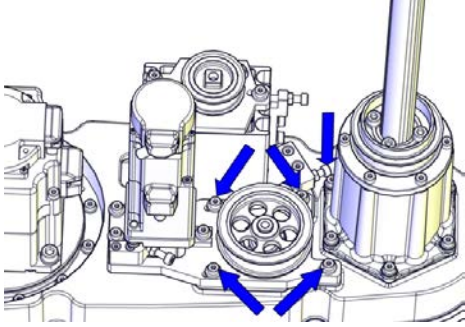
	Action	Note
1	 <b>DANGER</b>  Make sure that all supplies for electrical power, hydraulic pressure, and air pressure are turned off.	
2	 <b>WARNING</b>  Risk of tipping. Make sure the gravity center is well supported.	
3	Loosen the screws and move the axis-4 housing sideways to slacken the lower axis-4 timing belt.	 <p>xx1500002231</p>

Continues on next page



## 4 Repair

### 4.4.4 Replacing the axis-4 timing belts

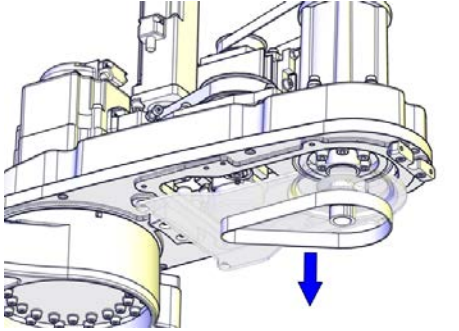
Continued

	Action	Note
4	Remove the timing belt.	 <p>xx1500002232</p>

### Removing the axis-4 drive unit and upper timing belt

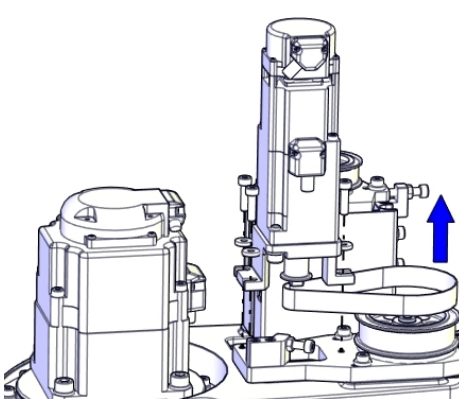
	Action	Note
1	 <p><b>DANGER</b></p> <p>Make sure that all supplies for electrical power, hydraulic pressure, and air pressure are turned off.</p>	
2	 <p><b>WARNING</b></p> <p>Risk of tipping. Make sure the gravity center is well supported.</p>	
3	Loosen the screws and move the axis-4 drive unit upwards to slacken the upper axis-4 timing belt.	 <p>xx1500002233</p>

Continues on next page

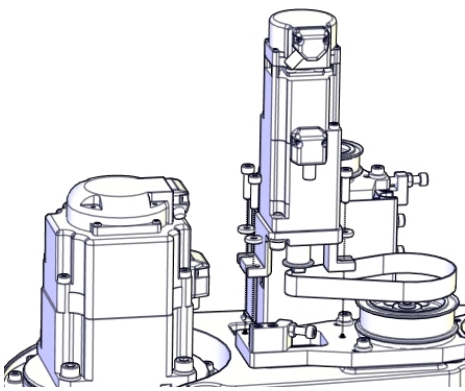
	Action	Note
4	Remove the drive unit and timing belt.	 <p>xx1500002234</p>

**Refitting the axis-4 timing belts**

Use these procedures to refit the axis-4 timing belts.

**Refitting the axis-4 drive unit and upper timing belt**

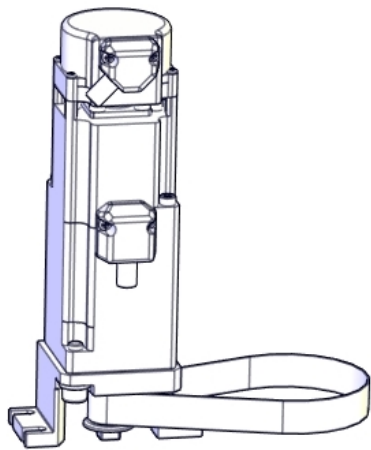

	Action	Note
1	Make sure that: <ul style="list-style-type: none"> <li>• all assembly surfaces are clean and undamaged.</li> <li>• the drive unit is clean and undamaged.</li> </ul>	
2	Place the timing belt.	Axis-4 drive unit: 3HAC056112-001 Upper axis-4 timing belt: 3HAC055206-001  <p>xx1500002801</p>

*Continues on next page*

## 4 Repair

### 4.4.4 Replacing the axis-4 timing belts

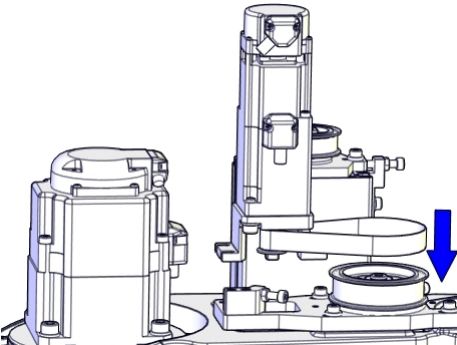
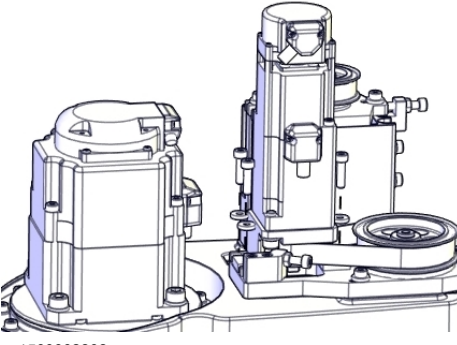
Continued

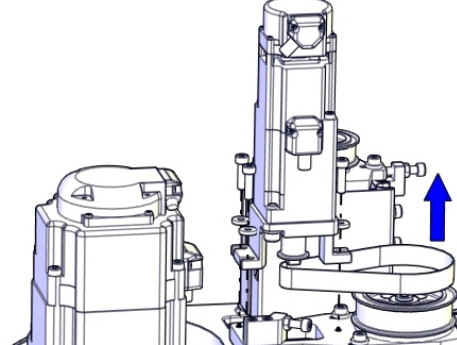
	Action	Note
3	<p>Refit the drive unit and timing belt.</p> <p> <b>Note</b></p> <p>Make sure to refit the drive unit with motor connectors pointing against axis-3 drive unit.</p>	 <p>xx1500002802</p>
4	<p>Refit screws and washers just enough to still be able to move the drive unit upwards.</p>	 <p>xx1500002803</p> <p>Screw: M4x16 (3 pcs) Washer (3HAC056937-001, 3 pcs)</p> <p> <b>Note</b></p> <p>Only use specified washers, never replace them with other washers.</p>
5	<p>Fasten the screws little by little while using a dynamometer to measure the belt tension until a proper belt tension is achieved.</p>	 <p>xx1500002233</p> <p>Belt tension: <math>F = 37 \text{ N}</math> (Recommended) Belt tension range: 24.1 N to 27.6 N (for used timing belt, which has been installed and used for more than 24 hours) 34.5 N to 37.9 N (for new timing belt)</p>

Continues on next page

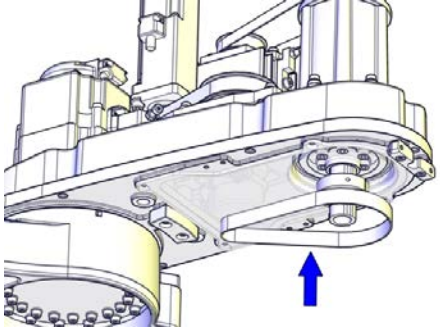
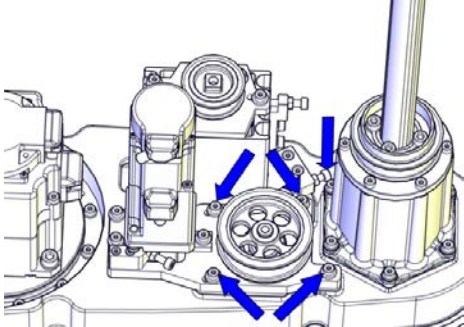

Refitting the lower axis-4 timing belt

	Action	Note
1	Make sure that: <ul style="list-style-type: none"> <li>all assembly surfaces are clean and undamaged.</li> <li>the drive unit is clean and undamaged.</li> </ul>	
2	Refit lower axis-4 timing belt. Ensure that the belt runs correctly in the grooves.	Lower axis-4 timing belt: 3HAC055201-001  xx1500002786
3	Fasten the screws little by little while using a dynamometer to measure the belt tension until a proper belt tension is achieved.	 xx1500002231 Belt tension: $F = 101 \text{ N}$ (Recommended) Belt tension range: 64.5 N to 73.7 N (for used timing belt, which has been installed and used for more than 24 hours) 92.2 N to 101 N (for new timing belt)

Refitting the lower cover

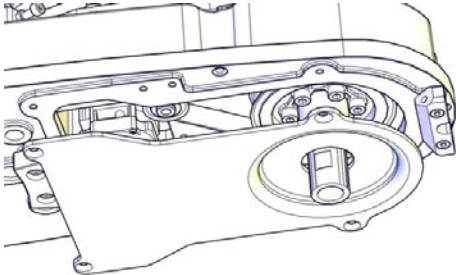
	Action	Note
1	Refit the cover.	Lower cover: 3HAC060106-001  xx1500002225

Continues on next page

## 4 Repair

### 4.4.4 Replacing the axis-4 timing belts

Continued

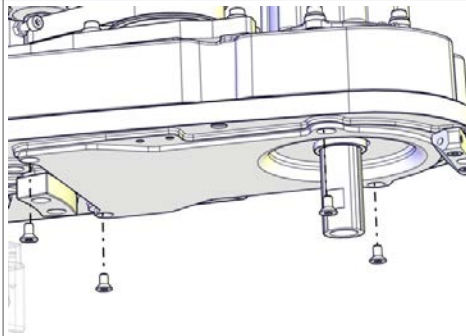

	Action	Note
2	Secure with screws.	 <p data-bbox="936 645 1050 667">xx1500002785</p> <p data-bbox="936 678 1214 745">Screw: M4x8 (4 pcs) Tightening torque: 2 Nm</p>

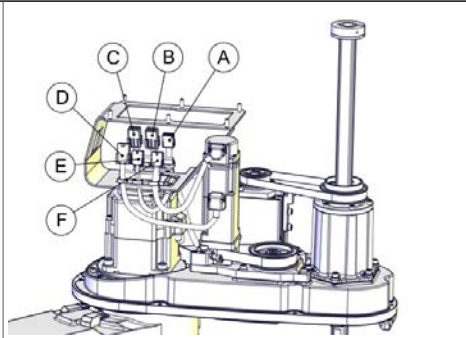
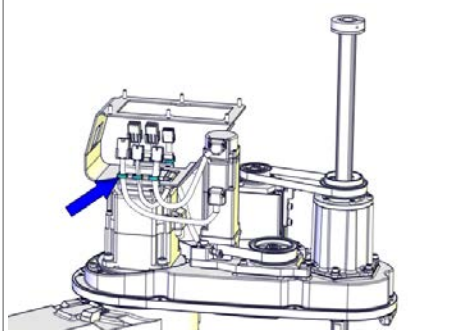
### Securing the drive unit cables

	Action	Note												
1	Put the drive unit cables in place.	 <p data-bbox="936 1205 1050 1227">xx1500003063</p> <table border="1" data-bbox="936 1238 1404 1518"> <tbody> <tr> <td data-bbox="936 1238 991 1276">A</td> <td data-bbox="995 1238 1404 1276">R2.ME3</td> </tr> <tr> <td data-bbox="936 1283 991 1321">B</td> <td data-bbox="995 1283 1404 1321">R2.MP2</td> </tr> <tr> <td data-bbox="936 1328 991 1366">C</td> <td data-bbox="995 1328 1404 1366">R2.MP3</td> </tr> <tr> <td data-bbox="936 1373 991 1411">D</td> <td data-bbox="995 1373 1404 1411">R2.MP4</td> </tr> <tr> <td data-bbox="936 1417 991 1456">E</td> <td data-bbox="995 1417 1404 1456">R2.ME2</td> </tr> <tr> <td data-bbox="936 1462 991 1500">F</td> <td data-bbox="995 1462 1404 1500">R2. ME4</td> </tr> </tbody> </table>	A	R2.ME3	B	R2.MP2	C	R2.MP3	D	R2.MP4	E	R2.ME2	F	R2. ME4
A	R2.ME3													
B	R2.MP2													
C	R2.MP3													
D	R2.MP4													
E	R2.ME2													
F	R2. ME4													
2	Secure the cables with cable ties. Do not tighten the ties too tight.	 <p data-bbox="936 1877 1050 1899">xx1500002226</p>												

Continues on next page

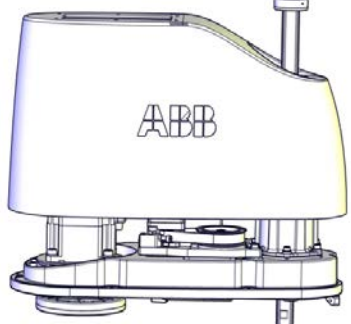
#### Refitting the upper cover

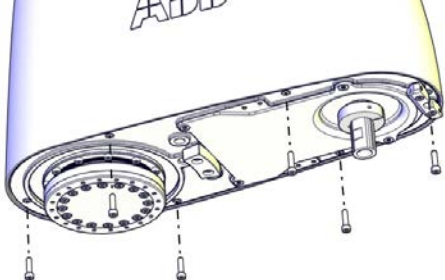
	Action	Note
1	Carefully put down the upper cover, avoiding any collision to the ball screw spline unit and drive units.	Upper cover unit: 3HAC057615-001  <small>xx1500002221</small>
2	 <b>Tip</b> Some of the screws are accessed from below. Make sure that the robot is properly fastened and hang out the upper arm from the workbench to access them.	
3	Refit the cover.	 <small>xx1500002220</small> Screw: M4x16 (6 pcs) Tightening torque: 2 Nm

#### Refitting the main cable to the upper arm

	Action	Note
1	Secure the main cable package with cable ties if needed.	

*Continues on next page*

## 4 Repair

### 4.4.4 Replacing the axis-4 timing belts

Continued

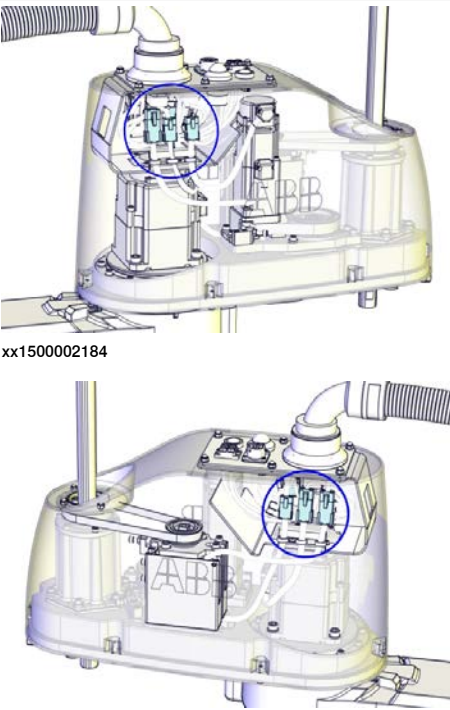
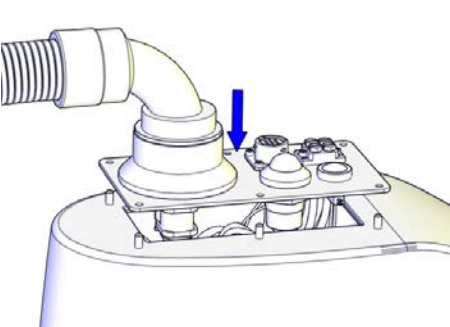
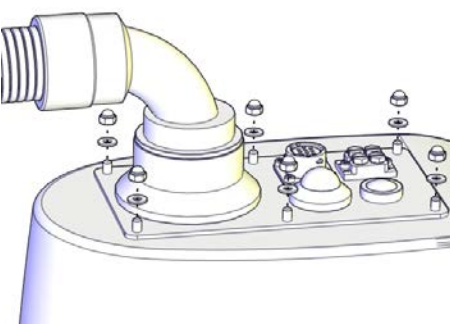
	Action	Note
2	<p>Reconnect the connectors.</p> <ul style="list-style-type: none"><li>• R2.MP2</li><li>• R2.MP3</li><li>• R2.MP4</li><li>• R2.ME2</li><li>• R2.ME3</li><li>• R2.ME4</li></ul>	 <p>Diagram illustrating the reconnection of connectors on the motor housing. The top image (xx1500002184) shows the motor housing with a blue circle highlighting the connector area. The bottom image (xx1500002185) shows the motor housing with a blue circle highlighting the connector area.</p> <p>xx1500002184</p> <p>xx1500002185</p>
3	<p>Push the main cable package into place.</p>	 <p>Diagram illustrating the main cable package being pushed into place. A blue arrow points to the cable package.</p> <p>xx1500002207</p>
4	<p>Refit the user interface plate.</p>	 <p>Diagram illustrating the refitting of the user interface plate. The plate is shown being secured with dome nuts and washers.</p> <p>xx1500002182</p> <p>Dome nut: M4 (6 pcs) Tightening torque: 2 Nm Washer, 6 pcs</p>

Continues on next page

## Concluding procedure

	Action	Note
1	Recalibrate the robot.	Calibration is detailed in section <a href="#">Calibration on page 349</a> .
2	 <b>DANGER</b> Make sure all safety requirements are met when performing the first test run. These are further detailed in the section "First test run may cause injury or damage" in <i>Safety manual for robot - Manipulator and IRC5 or OmniCore controller</i> .	

## 4 Repair

### 4.4.5 Replacing the axis-2 mechanical stop

### 4.4.5 Replacing the axis-2 mechanical stop

#### General



#### Note

If a collision with the mechanical stops occur, check and retighten all screws before any installation or service work. Replace damaged or cracked screws.

#### Location of the axis-2 mechanical stop

The axis-2 mechanical stop is located as shown in the figure.

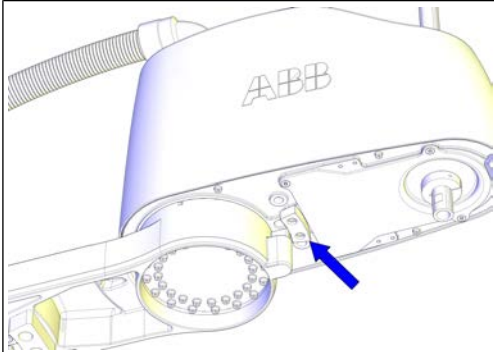
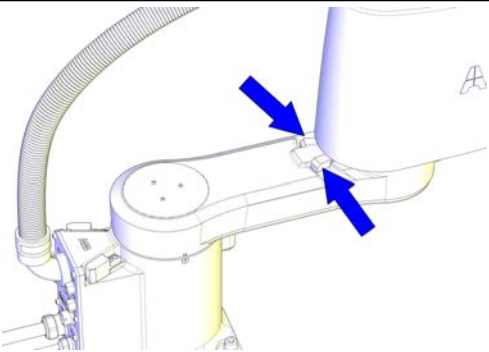
Axis-2 mechanical stop block	Axis-2 mechanical stop rubber
 xx1500002175	 xx1500002174
3HAC055185-001	3HAC056017-001

#### Required spare parts



#### Note

The spare part numbers that are listed in the table can be out of date. See the latest spare parts of the IRB 910SC via myABB Business Portal, [www.abb.com/myABB](http://www.abb.com/myABB).

Spare part	Article number	Note
Axis-2 mechanical stop rubber	3HAC056017-001	Replace if damaged.
Axis-2 mechanical stop block	3HAC055185-001	Replace if damaged.

#### Required tools and equipment

Equipment	Article number	Note
Standard toolkit	-	Content is defined in section <a href="#">Standard toolkit on page 392</a> .

#### Required consumables



Consumable	Article number	Note
Locking liquid	3HAB7116-1	Loctite 243

Continues on next page

**Replacing the axis-2 mechanical stop**

Use these procedures to replace the axis-2 mechanical stop.

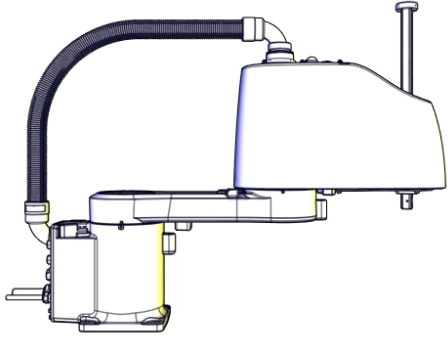
**Preparations before replacing the axis-2 mechanical stop**

	Action	Note
1	Jog all axes to zero position.	 <p>xx1500002227</p>
2	 <b>DANGER</b> Turn off all: <ul style="list-style-type: none"> <li>• electric power supply</li> <li>• hydraulic pressure supply</li> <li>• air pressure supply</li> </ul> to the robot, before entering the robot working area.	

**Replacing the axis-2 mechanical stop block**



	Action	Note
1	 <b>DANGER</b> Make sure that all supplies for electrical power, hydraulic pressure, and air pressure are turned off.	

*Continues on next page*



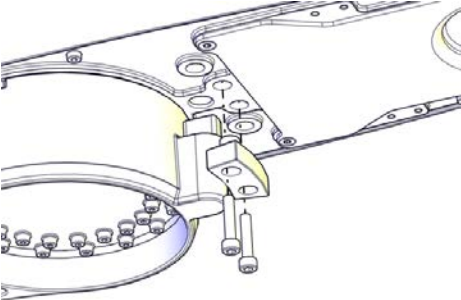

## 4 Repair

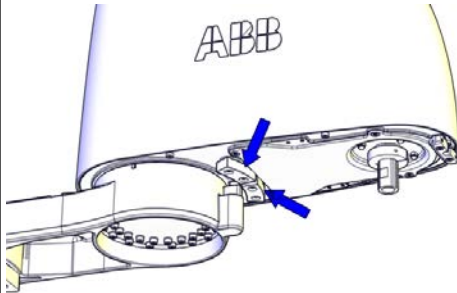
### 4.4.5 Replacing the axis-2 mechanical stop

Continued

Action	Note
2 Remove the block by removing the screws.	 <p data-bbox="943 645 1050 667">xx150002245</p> <p data-bbox="943 685 1214 745">Screw: M5x15 (2 pcs) Tightening torque: 5 Nm</p>
3 Refit and secure the new mechanical stop block.   <b>Tip</b>  One more mechanical stop block can be fitted to restrict the working range of axis 2, as shown in the following figure.  The block and related screws are provided in accessory package.   <p data-bbox="464 1010 576 1032">xx150003065</p>	

### Replacing the axis-2 mechanical stop rubbers

 <b>Note</b>  Two persons working together are required to perform this procedure.	
1  <b>DANGER</b>  Make sure that all supplies for electrical power, hydraulic pressure, and air pressure are turned off.	
2  <b>WARNING</b>  The upper arm weights 13.2 kg. It may drop by the force of gravity when it is released from the lower arm. Make sure the weight of the upper arm body is properly supported.	
3  <b>Note</b>  Two persons working together are required to perform this step.  Person 1: Hold the upper arm. Person 2: Remove the screws that fasten the upper arm to the lower arm.	

Continues on next page

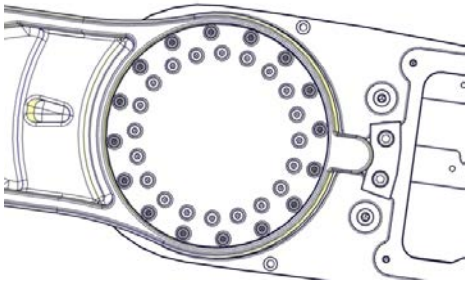
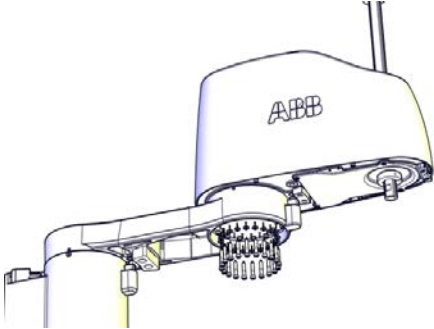
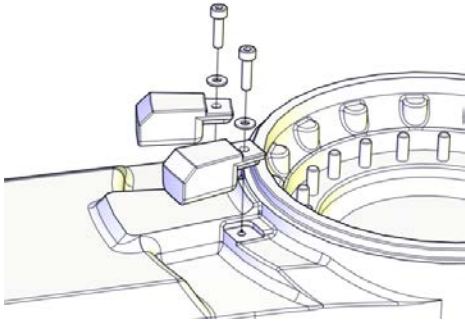
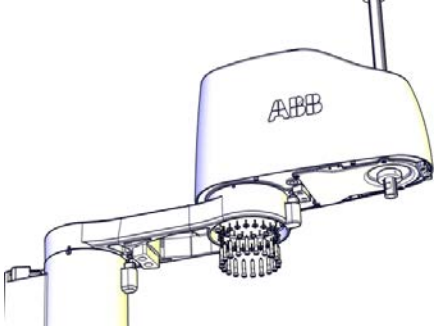

4.4.5 Replacing the axis-2 mechanical stop  
Continued

	Action	Note
4	<p>Remove the screws and washers.</p> <p> <b>WARNING</b></p> <p>Keep the twelve screws in the outer circle fitted. They hold the axis-2 motor flange on the lower arm.</p>  <p>xx1500002257</p>	 <p>xx1500002256</p>
5	<p>Remove the upper arm and lay it on a workbench.</p>	
6	<p>Remove the rubbers by removing the screws.</p>	
7	<p>Refit and secure the new mechanical stop rubbers with screws.</p> <p>Lock screws with locking liquid (Loctite 243).</p>	 <p>xx1500002246</p> <p>Screw: M3x6 (2 pcs) Tightening torque: 0.3 Nm</p>
8	<p>Make sure the lower arm is secured. Lower the upper arm down onto the right place of the lower arm.</p>	
9	<p>Refit the upper arm screws and washers.</p>	 <p>xx1500002256</p> <p>Screw: M4x20 (16 pcs) Tightening torque: 4.5 Nm</p>

Continues on next page

## 4 Repair

---

### 4.4.5 Replacing the axis-2 mechanical stop

*Continued*

Concluding procedure

	Action	Note
1	Recalibrate the robot.	Calibration is detailed in section <a href="#">Calibration on page 349</a> .
2	 <b>DANGER</b> Make sure all safety requirements are met when performing the first test run. These are further detailed in the section "First test run may cause injury or damage" in <i>Safety manual for robot - Manipulator and IRC5 or OmniCore controller</i> .	

## 4.5 Lower arm and base

### 4.5.1 Replacing the lower arm

#### Location of the lower arm

The lower arm is located as shown in the figure.

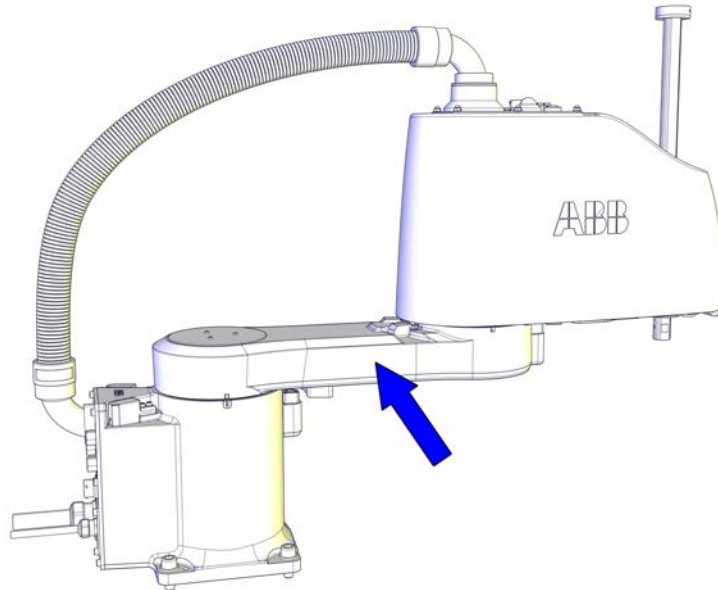

xx1500002210

#### Required spare parts



#### Note

The spare part numbers that are listed in the table can be out of date. See the latest spare parts of the IRB 910SC via myABB Business Portal, [www.abb.com/myABB](http://www.abb.com/myABB).

Spare part	Article number	Note
Lower arm, 450 mm	3HAC057609-001	Used for IRB 910SC-3/0.45
Lower arm, 550 mm	3HAC057612-001	Used for IRB 910SC-3/0.55
Lower arm, 650 mm	3HAC057613-001	Used for IRB 910SC-3/0.65
Lower arm cover	3HAC056065-001	Replace if damaged.

#### Required tools and equipment

Equipment	Article number	Note
Standard toolkit	-	Content is defined in section <a href="#">Standard toolkit on page 392</a> .

*Continues on next page*

## 4 Repair

### 4.5.1 Replacing the lower arm

*Continued*



#### Required consumables

Consumable	Article number	Note
Cable ties	-	

#### Removing the lower arm

Use these procedures to remove the lower arm.

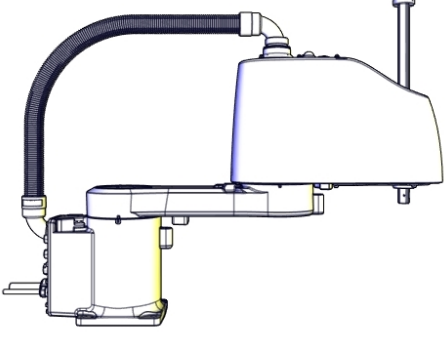



#### Preparations before removing the lower arm

	Action	Note
1	Jog all axes to zero position.	  xx1500002227
2	 <b>DANGER</b>  Turn off all: <ul style="list-style-type: none"><li>• electric power supply</li><li>• hydraulic pressure supply</li><li>• air pressure supply</li></ul> to the robot, before entering the robot working area.	

#### Removing the main cable package from the upper arm

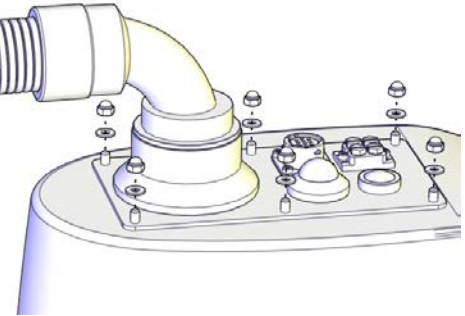
	Action	Note
1	 <b>DANGER</b>  Make sure that all supplies for electrical power, hydraulic pressure, and air pressure are turned off.	

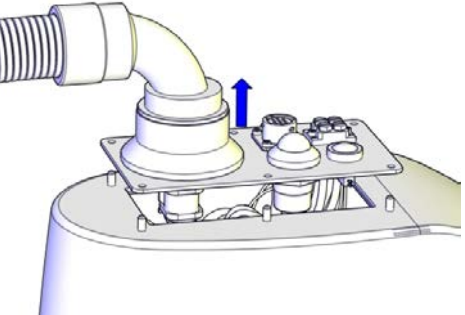
*Continues on next page*

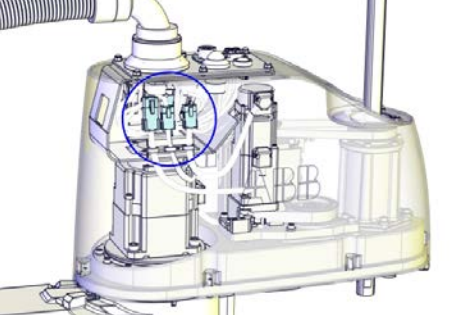
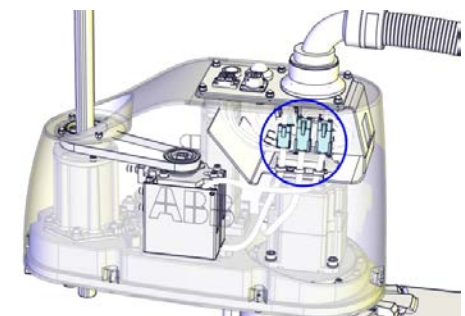
	Action	Note
2	Remove the dome nuts and washers.	 <p>xx1500002182</p>
3	Carefully open the user interface plate and pull out the cable package.   <b>CAUTION</b>  The plate cannot be removed completely until the connectors are disconnected, as shown in the following step.	 <p>xx1500002183</p>
4	Disconnect the connectors: <ul style="list-style-type: none"> <li>• R2.MP2</li> <li>• R2.MP3</li> <li>• R2.MP4</li> <li>• R2.ME2</li> <li>• R2.ME3</li> <li>• R2.ME4</li> </ul>  <b>Tip</b>  Take photos of the connectors and cable position before disconnecting them, to have as a reference when reconnecting.	 <p>xx1500002184</p>  <p>xx1500002185</p>

#### Removing the upper arm



#### Note





Two persons working together are required to perform this procedure.

*Continues on next page*

## 4 Repair

### 4.5.1 Replacing the lower arm

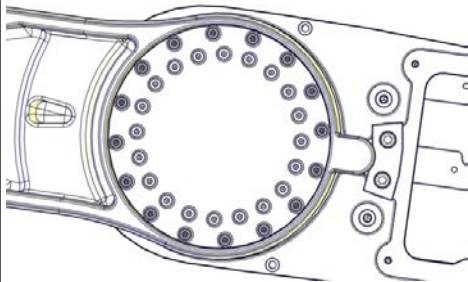
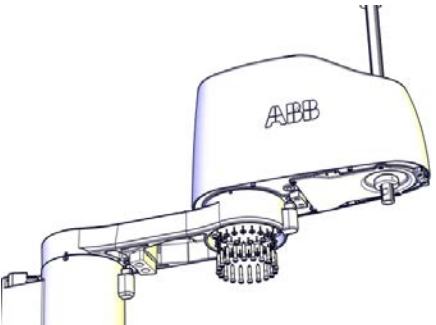

Continued

	Action	Note
1	 <b>DANGER</b> Make sure that all supplies for electrical power, hydraulic pressure, and air pressure are turned off.	
2	 <b>WARNING</b> The upper arm weights 13.2 kg. It may drop by the force of gravity when it is released from the lower arm. Make sure the weight of the upper arm body is properly supported.	
3	 <b>Note</b> Two persons working together are required to perform this step. Person 1: Hold the upper arm. Person 2: Remove the screws that fasten the upper arm to the lower arm.	
4	Remove the screws and washers.  <b>WARNING</b> Keep the twelve screws in the outer circle fitted. They hold the axis-2 motor flange on the lower arm.  <small>xx1500002257</small>	 <small>xx1500002256</small>
5	Remove the upper arm and lay it aside on a workbench.	

#### Removing the lower arm

	Action	Note
1	 <b>DANGER</b> Make sure that all supplies for electrical power, hydraulic pressure, and air pressure are turned off.	

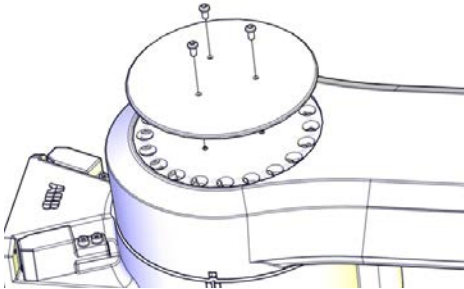
Continues on next page

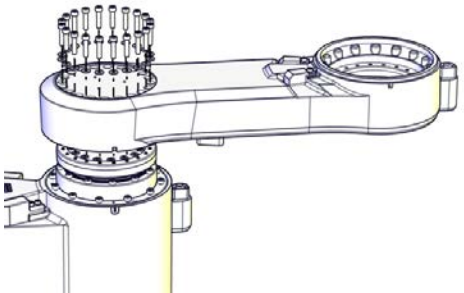
	Action	Note
2	<p>Remove the cover.</p> <p> <b>Tip</b></p> <p>If the cover is hard to remove, fit a screw to its attachment hole to help press out the cover.</p>	 <p>xx1500002259</p>
3	<p> <b>WARNING</b></p> <p>The lower arm weights 3.2 kg. It may drop when it is released from the base. Make sure the weight of the lower arm is properly supported.</p>	
4	Remove the screws and washers.	
5	Lay the lower arm aside on a workbench.	 <p>xx1500002260</p>

## 4 Repair

### 4.5.1 Replacing the lower arm

*Continued*

#### Refitting the lower arm

Use these procedures to refit the lower arm.

#### Refitting the lower arm

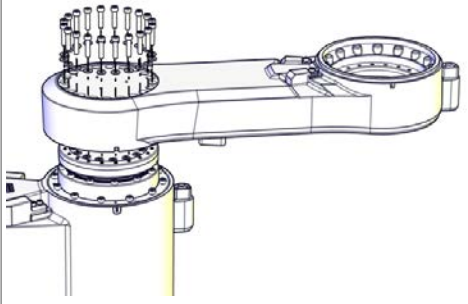
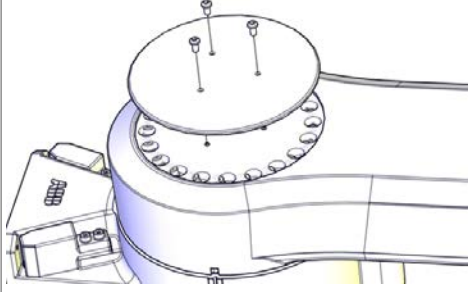
	Action	Note
1	Refit the lower arm and tighten screws.	<p>Lower arm, 450 mm: 3HAC057609-001 (For IRB 910SC-3/0.45) Lower arm, 550 mm: 3HAC057612-001 (For IRB 910SC-3/0.65) Lower arm, 650 mm: 3HAC057613-001 (For IRB 910SC-3/0.65)</p>  <p>xx1500002260</p> <p>Screw: M4x20 (16 pcs) Tightening torque: 4.2 Nm Washer: 4.3x9x1.3 (16 pcs)</p>
2	Refit the cover.	<p>Lower arm cover: 3HAC056065-001</p>  <p>xx1500002259</p> <p>Screw: M3x6 (3 pcs) Tightening torque: 1 Nm</p>

#### Refitting the upper arm



#### Note

Two persons working together are required to perform this procedure.

*Continues on next page*

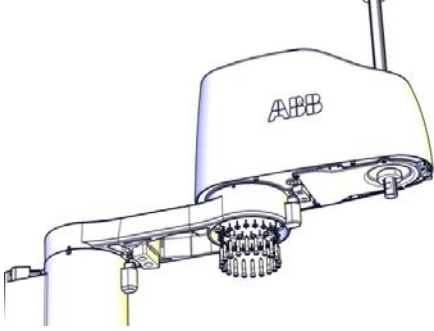

	Action	Note
1	 <b>Note</b> Two persons working together are required to perform this step. Person 1: Hold the upper arm. Person 2: Refit the screws that fasten the upper arm to the lower arm.	
2	Make sure the lower arm is secured. Lower the upper arm down onto the right place of the lower arm.	
3	Refit the upper arm screws and washers.	 <p data-bbox="970 1010 1082 1025">xx1500002256</p> <p data-bbox="970 1048 1225 1070">Screw: M4x20 (16 pcs)</p> <p data-bbox="970 1077 1262 1099">Tightening torque: 4.5 Nm</p> <p data-bbox="970 1106 1273 1128">Washer: 4.3x9x1.3 (16 pcs)</p>

## Refitting the main cable to the upper arm

	Action	Note
1	Secure the main cable package with cable ties if needed.	

## 4 Repair

### 4.5.1 Replacing the lower arm

Continued

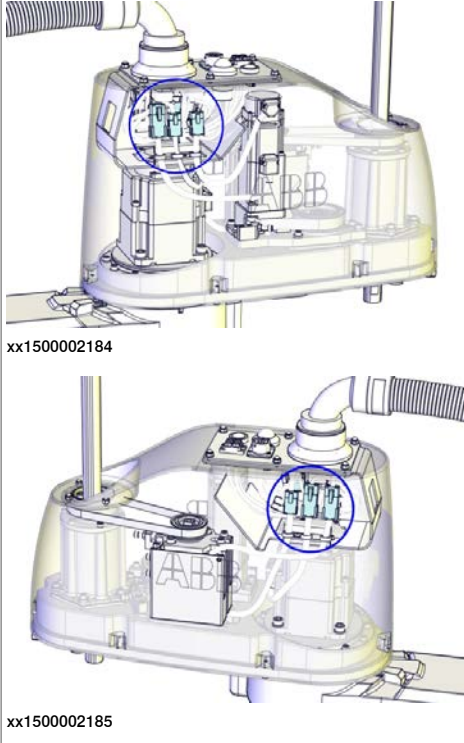
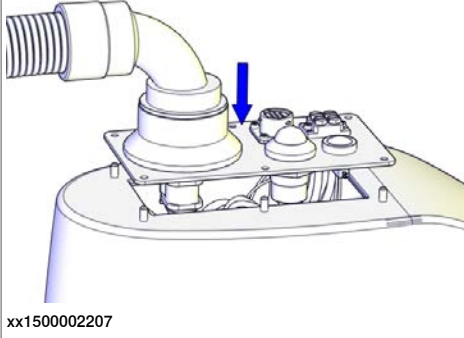
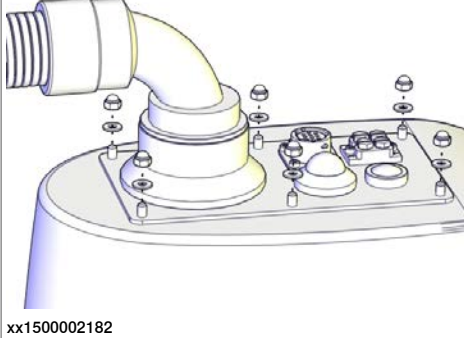
	Action	Note
2	<p>Reconnect the connectors.</p> <ul style="list-style-type: none"><li>• R2.MP2</li><li>• R2.MP3</li><li>• R2.MP4</li><li>• R2.ME2</li><li>• R2.ME3</li><li>• R2.ME4</li></ul>	 <p>Diagram illustrating the reconnection of connectors. The top image (xx1500002184) shows the lower arm assembly with a blue circle highlighting the connector area. The bottom image (xx1500002185) shows the same assembly from a different angle, also highlighting the connector area.</p>
3	<p>Push the main cable package into place.</p>	 <p>Diagram illustrating the main cable package being pushed into place. A blue arrow points to the cable package being inserted into the assembly.</p>
4	<p>Refit the user interface plate.</p>	 <p>Diagram illustrating the refitting of the user interface plate. The plate is shown being secured to the assembly with dome nuts and washers.</p> <p>xx1500002182</p> <p>Dome nut: M4 (6 pcs) Tightening torque: 2 Nm Washer, 6 pcs</p>

Continues on next page

## Concluding procedure

	Action	Note
1	Recalibrate the robot.	Calibration is detailed in section <a href="#">Calibration on page 349</a> .
2	 <b>DANGER</b> Make sure all safety requirements are met when performing the first test run. These are further detailed in the section "First test run may cause injury or damage" in <i>Safety manual for robot - Manipulator and IRC5 or OmniCore controller</i> .	

## 4 Repair

### 4.5.2 Replacing the base

### 4.5.2 Replacing the base

#### Location of the base

The base is located as shown in the figure.

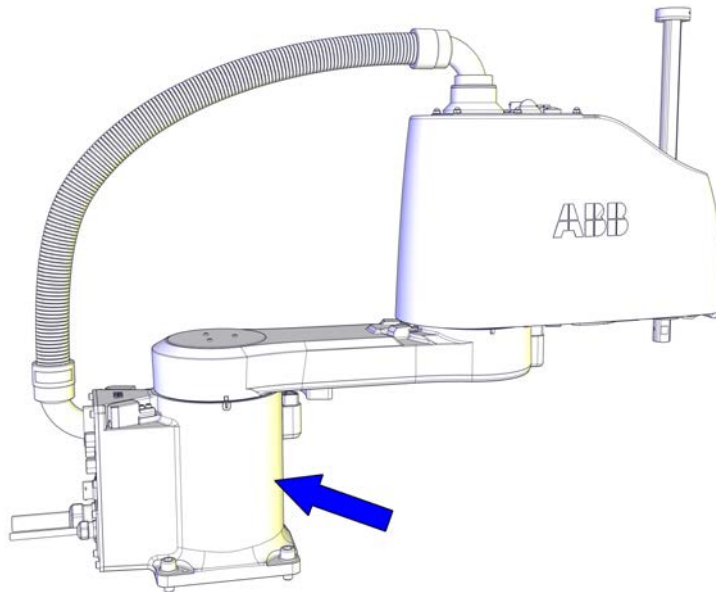

xx1500002211

#### Required spare parts



#### Note

The spare part numbers that are listed in the table can be out of date. See the latest spare parts of the IRB 910SC via myABB Business Portal, [www.abb.com/myABB](http://www.abb.com/myABB).

Spare part	Article number	Note
Base	3HAC057614-001	
Base bottom cover	3HAC055216-001	Replace if damaged.
Lower arm cover	3HAC056065-001	Replace if damaged.

#### Required tools and equipment

Equipment	Article number	Note
Standard toolkit	-	Content is defined in section <a href="#">Standard toolkit on page 392</a> .

*Continues on next page*



Required consumables

Consumable	Article number	Note
Cable ties	-	

Removing the cabling from the base

Use these procedures to remove the cabling from the base.

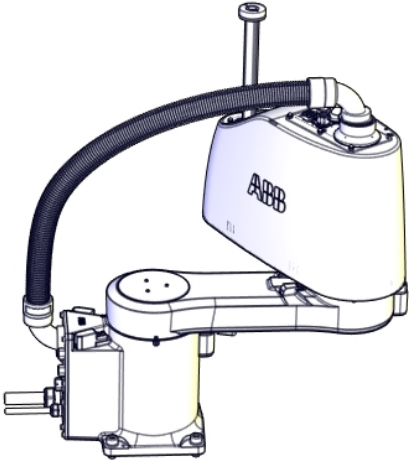
Preparations before replacing the base

Action	Note
1 Jog axis 2 to easily support the arm system weight.	 <p>xx1500002804</p>
<p> <b>DANGER</b></p> <p>Turn off all:</p> <ul style="list-style-type: none"> <li>• electric power supply</li> <li>• hydraulic pressure supply</li> <li>• air pressure supply</li> </ul> <p>to the robot, before entering the robot working area.</p>	

Removing the main cable package from the base





Action	Note
<p> <b>DANGER</b></p> <p>Make sure that all supplies for electrical power, hydraulic pressure, and air pressure are turned off.</p>	

Continues on next page

## 4 Repair

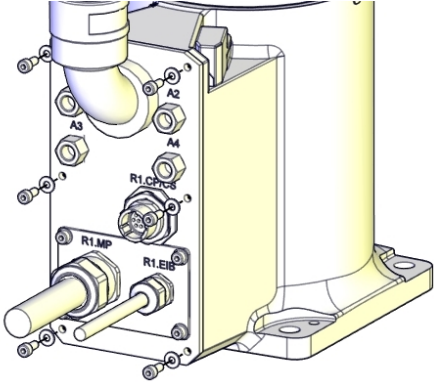
### 4.5.2 Replacing the base

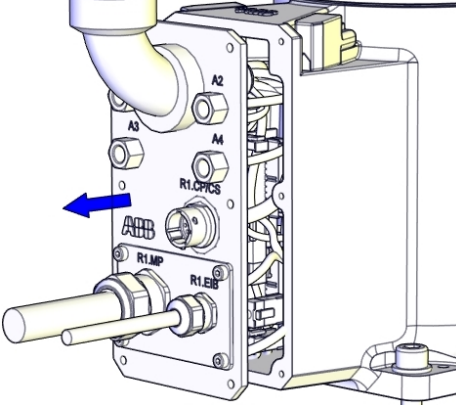
Continued

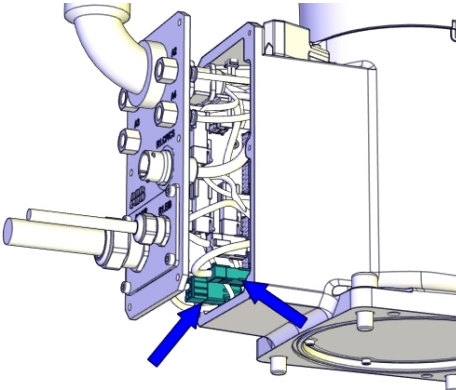
	Action	Note
2	Remove the screws and washers.	 xx1500002186
3	<p>Carefully open the base cover and pull out the cable package.</p> <p> <b>CAUTION</b></p> <p>The cover cannot be removed completely until the connectors are disconnected.</p> <p> <b>CAUTION</b></p> <p>Clean cover from metal residues before opening.</p> <p>Metal residues can cause shortage on the boards which can result in hazardous failures.</p>	 xx1500002187
4	<p>Disconnect the connectors:</p> <ul style="list-style-type: none"><li>• R2.MP1</li><li>• R2.ME1</li></ul> <p> <b>Tip</b></p> <p>Take photos of the connectors and cable position before disconnecting them, to have as a reference when reconnecting.</p>	 xx1500002188

### Replacing the base

Use these procedures to replace the base.







### Removing the arm system

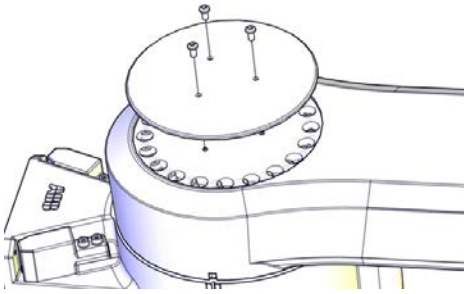

#### Note

Two persons working together are required to perform this procedure.

Continues on next page

	Action	Note
1	<p> <b>DANGER</b></p> <p>Turn off all:</p> <ul style="list-style-type: none"> <li>• electric power supply</li> <li>• hydraulic pressure supply</li> <li>• air pressure supply</li> </ul> <p>to the robot, before entering the robot working area.</p>	
2	<p>Remove the cover.</p> <p> <b>Tip</b></p> <p>If the cover is hard to remove, fit a screw to its attachment hole to help press out the cover.</p>	 <p>xx1500002259</p>
3	<p> <b>WARNING</b></p> <p>The arm system weights 16.4 kg. The arm system may drop when released from the base. Make sure the weight of the arm system is properly supported.</p>	
4	<p> <b>Note</b></p> <p>Two persons working together are required to perform this step. Person 1: Hold the arm system. Person 2: Remove the screws that fasten the arm system to the base.</p>	
5	<p> <b>CAUTION</b></p> <p>Handle the main cable package with care. Minimum bending radius is approximately 10 times of the cable diameter.</p>	

Continues on next page

## 4 Repair

### 4.5.2 Replacing the base

Continued

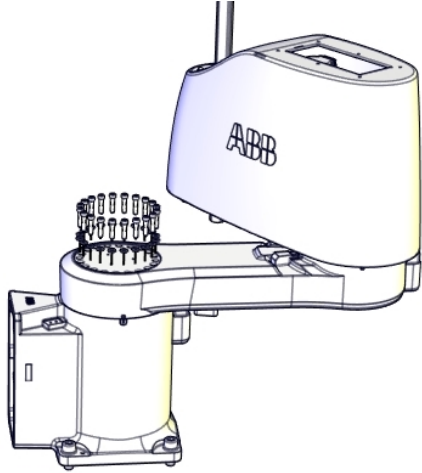
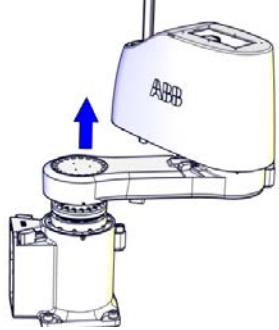

	Action	Note
6	Remove the screws and washers.	 <p>xx1500002805</p>
7	Remove the arm system and lay it aside on a workbench.	 <p>xx1500002261</p>

### Removing the axis-1 drive unit

	Action	Note
1	 <b>DANGER</b> Make sure that all supplies for electrical power, hydraulic pressure, and air pressure are turned off.	

Continues on next page

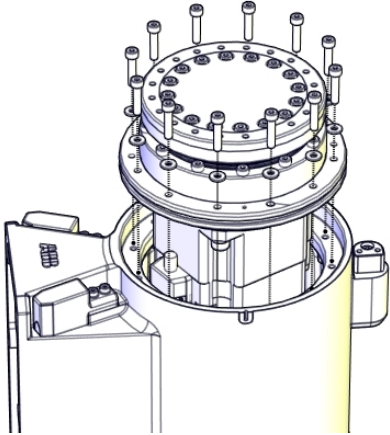

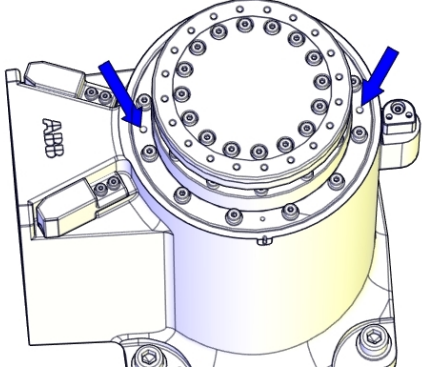
	Action	Note
2	<p>Remove the screws and washers.</p> <p> <b>WARNING</b></p> <p>Do not remove the inner circle screws. They are holding the gearbox together and removing them may damage the gearbox severely.</p>	
3	<p>Pull the drive unit out carefully while pulling the motor cables out of the base rear.</p> <p> <b>Tip</b></p> <p>If the drive unit is hard to remove, insert two M3 screws and press out the drive unit.</p>  <p>xx1500002263</p>	<p>xx1500002262</p>

Removing the base

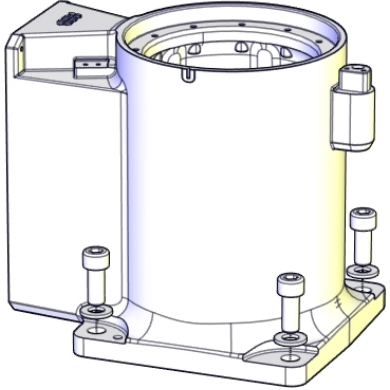
	Action	Note
1	<p> <b>DANGER</b></p> <p>Make sure that all supplies for electrical power, hydraulic pressure, and air pressure are turned off.</p>	
2	<p>Remove the attachment screws and washers.</p>	 <p>xx1500002264</p>

Continues on next page

## 4 Repair

### 4.5.2 Replacing the base

Continued

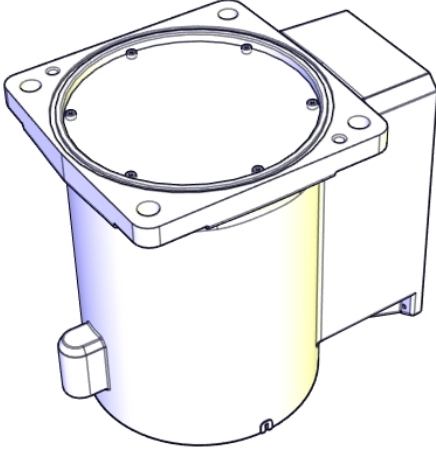
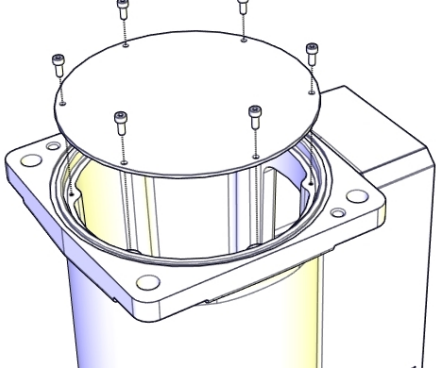
	Action	Note
3	Put the base on its side.	 <p>xx1500002806</p>
4	Remove the bottom cover.	 <p>xx1500002265</p>

### Refitting the base

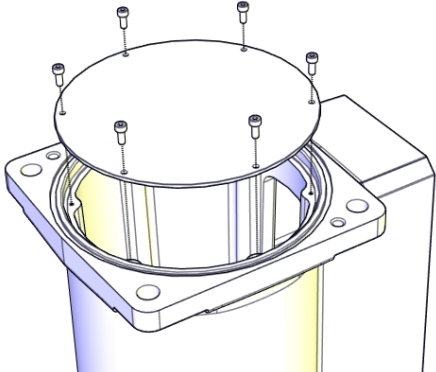
	Action	Note
1	Refit the bottom cover.	<p>Base bottom cover: 3HAC055216-001</p>  <p>xx1500002265</p> <p>Screw: M3x8 (6 pcs) Tightening torque: 2 Nm</p>

Continues on next page

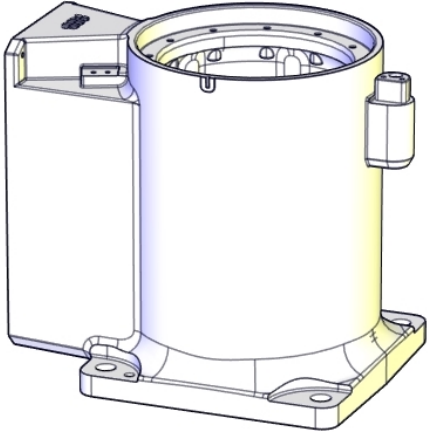
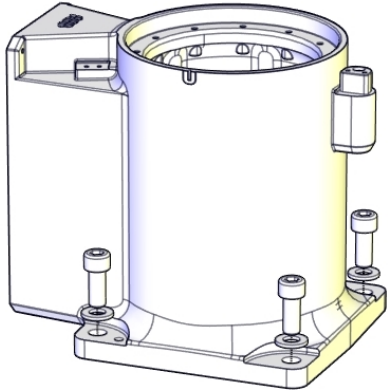
	Action	Note
2	Put the base in a raised position.	 <p>xx1500002807</p>
3	Fasten the attachment screws and washers.	 <p>xx1500002264</p> <p>Attachment screws: M10x25 (4 pcs), quality: 8.8. Washers: 20x10.5x2. Pin: 2 pcs, D6x20, ISO 2338 - 6m6x20 - A1. Tightening Torque: 45 Nm.</p>

#### Refitting the axis-1 drive unit

	Action	Note
1	Make sure that: <ul style="list-style-type: none"> <li>• all assembly surfaces are clean and undamaged.</li> <li>• the drive unit is clean and undamaged.</li> </ul>	

*Continues on next page*

## 4 Repair

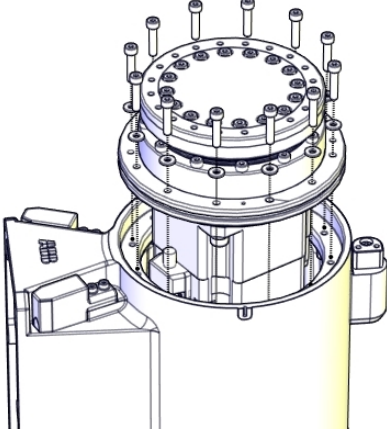
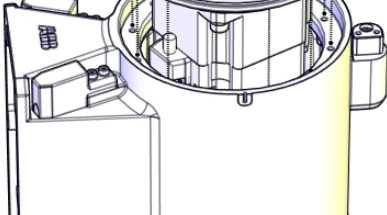

### 4.5.2 Replacing the base

Continued

	Action	Note
2	Carefully insert the complete drive unit while pulling the motor cables out of the base rear.   <b>CAUTION</b>  Do not mix axis-1 and axis-2 drive units. Always check the mark or label on the drive units before refitting.	Axis-1 drive unit: 3HAC055900-001  
3	Refit the screws and washers.	  <small>xx1500002262</small>  Screw: M4x20 (12 pcs) Tightening torque: 4.5 Nm Washer: 4.3x9x1 (12 pcs)

### Refitting the arm system

	<b>Note</b>
<p>Two persons working together are required to perform this procedure.</p>	

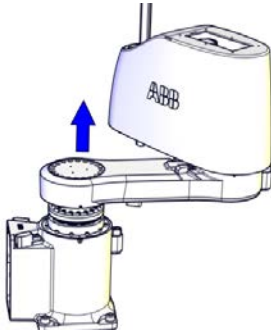
	Action	Note
1	 <b>Note</b>  Two persons working together are required to perform this step. Person 1: Hold the arm system. Person 2: Refit the screws that fasten the arm system to the base.	
2	Refit the whole arm system.   <b>WARNING</b>  The arm system weights 16.4 kg. Support the gravity center properly.	  <small>xx1500002261</small>  Screw: M4x20 (16 pcs) Tightening torque: 4.2 Nm Washer: 4.3x9x1.3 (16 pcs)

Continues on next page

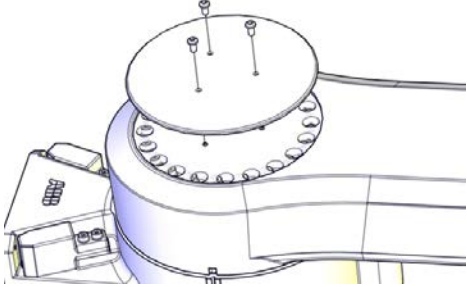
	Action	Note
3	 <b>CAUTION</b> Handle the main cable package with care. Minimum bending radius is approximately 10x the cable diameter.	
4	Refit the cover.	Lower arm cover: 3HAC056065-001  xx1500002259 Screw: M3x6 (3 pcs) Tightening torque: 1 Nm

#### Refitting the cabling to the base

Use these procedures to refit the cabling to the base.

#### Refitting the main cable to the base

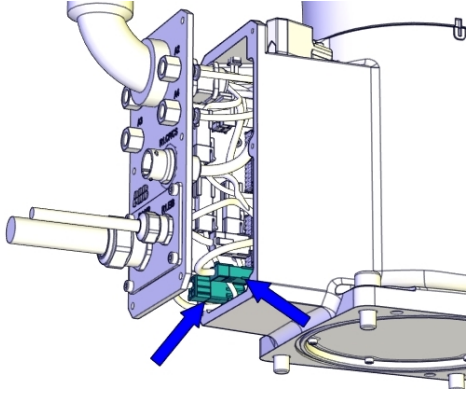
	Action	Note
1	Secure the main cable package with cable ties if needed.	
2	Reconnect the connectors. <ul style="list-style-type: none"> <li>• R2.MP1</li> <li>• R2.ME1</li> </ul>	 xx1500002188

*Continues on next page*

## 4 Repair

### 4.5.2 Replacing the base

Continued

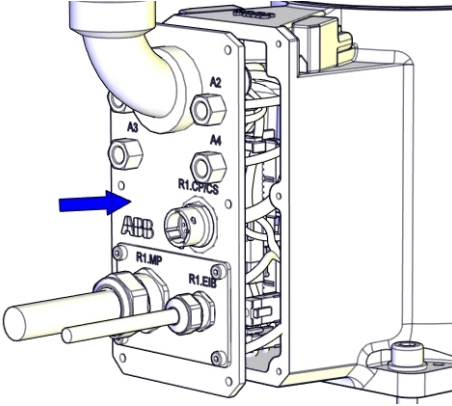
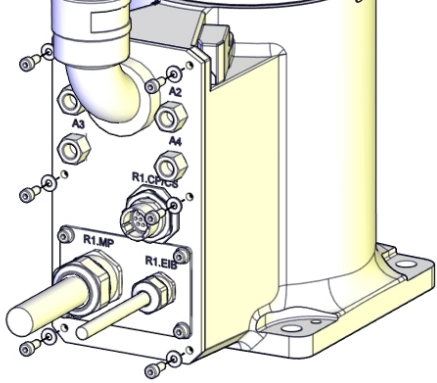
	Action	Note
3	Push the main cable package into place.	 <p>xx1500002204</p>
4	Refit the base cover with screws and washers.	 <p>xx1500002186</p> <p>Screws: M4x10 (6 pcs) Tightening torque: 2 Nm</p>

### Concluding procedure

	Action	Note
1	Recalibrate the robot.	Calibration is detailed in section <a href="#">Calibration on page 349</a> .
2	 <p><b>DANGER</b></p> <p>Make sure all safety requirements are met when performing the first test run. These are further detailed in the section "First test run may cause injury or damage" in <i>Safety manual for robot - Manipulator and IRC5 or OmniCore controller</i>.</p>	

### 4.5.3 Replacing the axis-1 mechanical stop

#### General



#### Note

If a collision with the mechanical stops occur, check and retighten all screws before any installation or service work. Replace damaged or cracked screws.

#### Location of the axis-1 mechanical stop

The axis-1 mechanical stop is located as shown in the figure.

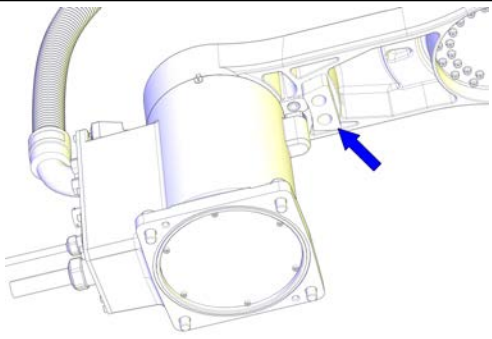
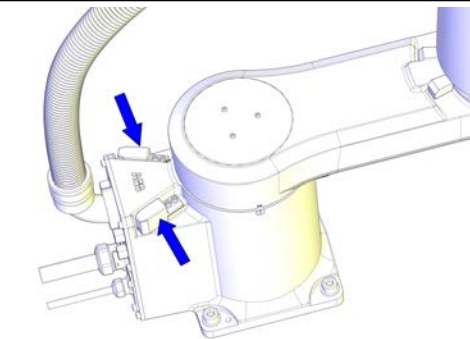
Axis-1 mechanical stop block	Axis-1 mechanical stop rubber
 <p>xx1500002177</p>	 <p>xx1500002176</p>
3HAC055164-001	3HAC056042-001

#### Required spare parts



#### Note

The spare part numbers that are listed in the table can be out of date. See the latest spare parts of the IRB 910SC via myABB Business Portal, [www.abb.com/myABB](http://www.abb.com/myABB).

Spare part	Article number	Note
Axis-1 mechanical stop rubber	3HAC056042-001	Replace if damaged.
Axis-1 mechanical stop block	3HAC055164-001	Replace if damaged.

#### Required tools and equipment

Equipment	Article number	Note
Standard toolkit	-	Content is defined in section <a href="#">Standard toolkit on page 392</a> .

#### Required consumables

Consumable	Article number	Note
Locking liquid	3HAB7116-1	Loctite 243

*Continues on next page*

## 4 Repair



### 4.5.3 Replacing the axis-1 mechanical stop

*Continued*

#### Replacing the axis-1 mechanical stop

Use these procedures to replace the axis-1 mechanical stop.

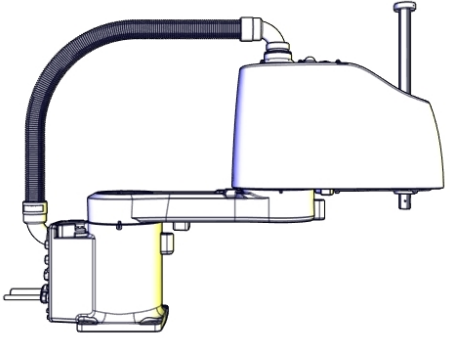
#### Preparations before replacing the axis-1 mechanical stop

	Action	Note
1	Jog all axes to zero position.	 <p>xx1500002227</p>
2	 <p><b>DANGER</b></p> <p>Turn off all:</p> <ul style="list-style-type: none"> <li>• electric power supply</li> <li>• hydraulic pressure supply</li> <li>• air pressure supply</li> </ul> <p>to the robot, before entering the robot working area.</p>	

#### Replacing the axis-1 mechanical stop block

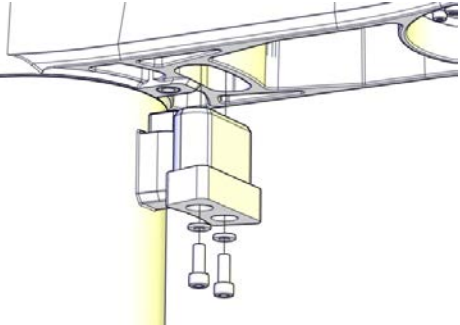
	Action	Note
1	 <p><b>DANGER</b></p> <p>Make sure that all supplies for electrical power, hydraulic pressure, and air pressure are turned off.</p>	
2	Remove the block by removing the screws and washers.	 <p>xx1500002247</p> <p>Screw: 9ADA183-24 (M6x16, 2 pcs) Tightening torque: 6 Nm Washer: 9ADA312-6 (M6, 2 pcs)</p>
3	Refit and secure the new mechanical stop block.	

*Continues on next page*

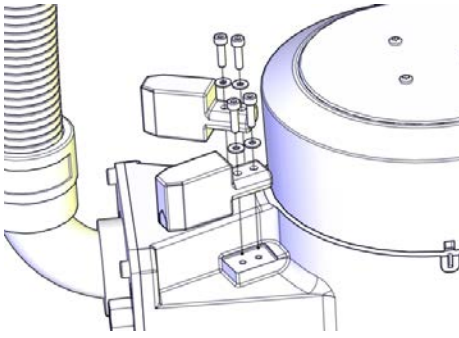

## Replacing the axis-1 mechanical stop rubbers

	Action	Note
1	 <b>DANGER</b> Make sure that all supplies for electrical power, hydraulic pressure, and air pressure are turned off.	
2	Remove the rubbers by removing the screws.	 xx1500002255
3	Refit and secure the new mechanical stop rubbers with screws. Lock screws with locking liquid (Loctite 243).	Screw: M3x12 (4 pcs) Tightening torque: 0.3 Nm

## Concluding procedure

	Action	Note
1	Recalibrate the robot.	Calibration is detailed in section <a href="#">Calibration on page 349</a> .
2	 <b>DANGER</b> Make sure all safety requirements are met when performing the first test run. These are further detailed in the section "First test run may cause injury or damage" in <i>Safety manual for robot - Manipulator and IRC5 or OmniCore controller</i> .	

## 4 Repair

### 4.6.1 Replacing the axis-1 drive unit

## 4.6 Drive units

### 4.6.1 Replacing the axis-1 drive unit

#### Location of the axis-1 drive unit

The axis-1 drive unit is located as shown in the figure.

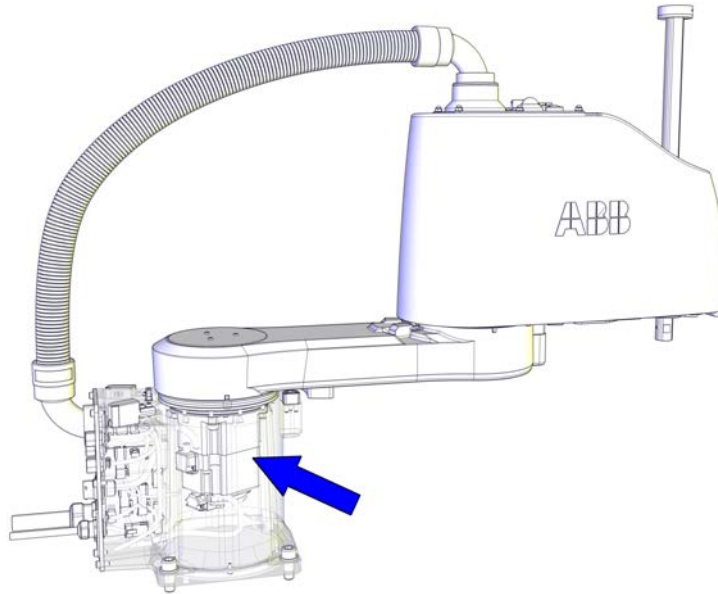

xx1500002213

#### Required spare parts



#### Note

The spare part numbers that are listed in the table can be out of date. See the latest spare parts of the IRB 910SC via myABB Business Portal, [www.abb.com/myABB](http://www.abb.com/myABB).

Spare part	Article number	Note
Axis-1 drive unit	3HAC055900-001	Includes axis-1 gearbox, motor and motor adapter.
Lower arm cover	3HAC056065-001	Replace if damaged.

#### Required tools and equipment

Equipment	Article number	Note
Standard toolkit	-	Content is defined in section <a href="#">Standard toolkit on page 392</a> .

*Continues on next page*



## Required consumables

Consumable	Article number	Note
Cable ties	-	

## Removing the axis-1 drive unit

Use these procedures to remove the axis-1 drive unit.

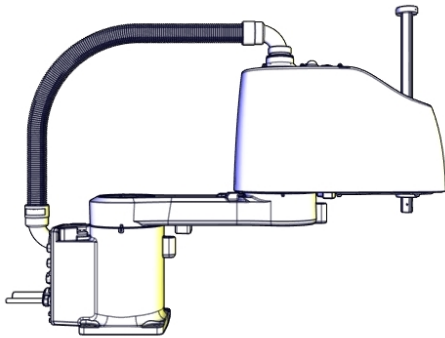
## Preparations before removing the axis-1 drive unit

	Action	Note
1	Jog all axes to zero position.	 xx1500002227
2	 <b>DANGER</b> Turn off all: <ul style="list-style-type: none"> <li>• electric power supply</li> <li>• hydraulic pressure supply</li> <li>• air pressure supply</li> </ul> to the robot, before entering the robot working area.	

## Removing the main cable package from the base





	Action	Note
1	 <b>DANGER</b> Make sure that all supplies for electrical power, hydraulic pressure, and air pressure are turned off.	

Continues on next page

## 4 Repair

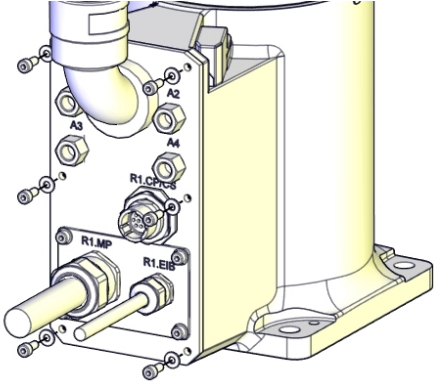
### 4.6.1 Replacing the axis-1 drive unit

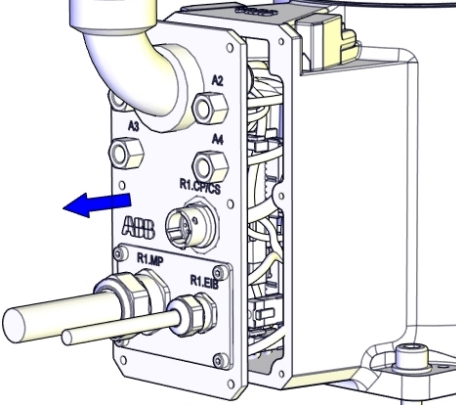
Continued

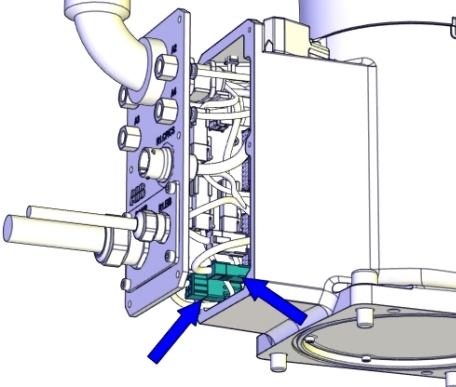
	Action	Note
2	Remove the screws and washers.	 xx1500002186
3	<p>Carefully open the base cover and pull out the cable package.</p> <p> <b>CAUTION</b></p> <p>The cover cannot be removed completely until the connectors are disconnected.</p> <p> <b>CAUTION</b></p> <p>Clean cover from metal residues before opening.</p> <p>Metal residues can cause shortage on the boards which can result in hazardous failures.</p>	 xx1500002187
4	<p>Disconnect the connectors:</p> <ul style="list-style-type: none"><li>• R2.MP1</li><li>• R2.ME1</li></ul> <p> <b>Tip</b></p> <p>Take photos of the connectors and cable position before disconnecting them, to have as a reference when reconnecting.</p>	 xx1500002188







### Removing the arm system

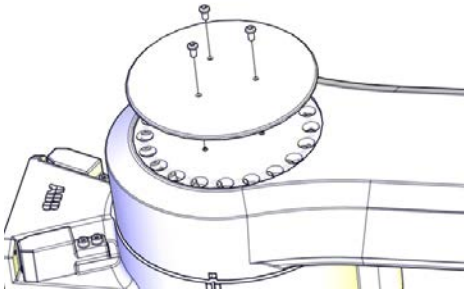

#### Note

Two persons working together are required to perform this procedure.

Continues on next page

	Action	Note
1	<p> <b>DANGER</b></p> <p>Turn off all:</p> <ul style="list-style-type: none"> <li>• electric power supply</li> <li>• hydraulic pressure supply</li> <li>• air pressure supply</li> </ul> <p>to the robot, before entering the robot working area.</p>	
2	<p>Remove the cover.</p> <p> <b>Tip</b></p> <p>If the cover is hard to remove, fit a screw to its attachment hole to help press out the cover.</p>	 <p>xx1500002259</p>
3	<p> <b>WARNING</b></p> <p>The arm system weights 16.4 kg. The arm system may drop when released from the base. Make sure the weight of the arm system is properly supported.</p>	
4	<p> <b>Note</b></p> <p>Two persons working together are required to perform this step.</p> <p>Person 1: Hold the arm system.</p> <p>Person 2: Remove the screws that fasten the arm system to the base.</p>	
5	<p> <b>CAUTION</b></p> <p>Handle the main cable package with care. Minimum bending radius is approximately 10 times of the cable diameter.</p>	

## 4 Repair

### 4.6.1 Replacing the axis-1 drive unit

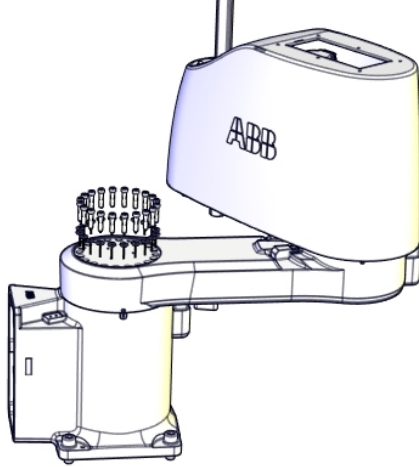
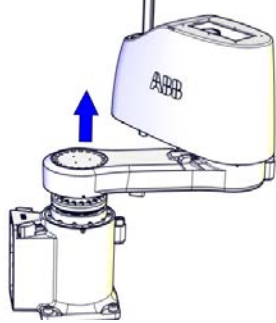

Continued

	Action	Note
6	Remove the screws and washers.	 xx1500002805
7	Remove the arm system and lay it aside on a workbench.	 xx1500002261

### Removing the axis-1 drive unit

	Action	Note
1	 <b>DANGER</b> Make sure that all supplies for electrical power, hydraulic pressure, and air pressure are turned off.	

Continues on next page

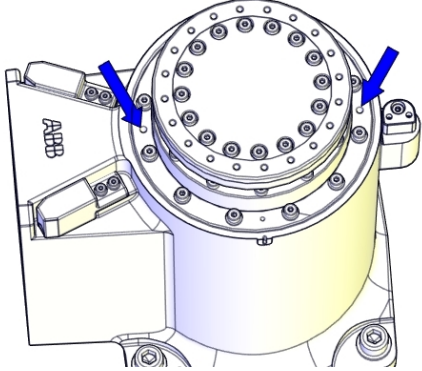
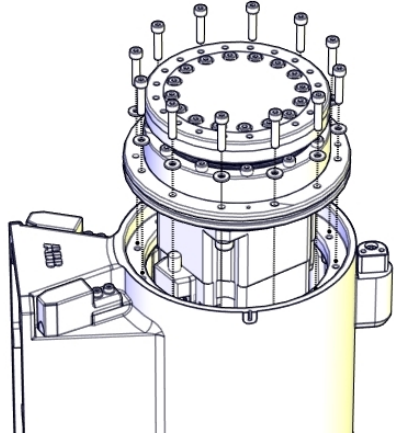
	Action	Note
2	<p>Remove the screws and washers.</p> <p> <b>WARNING</b></p> <p>Do not remove the inner circle screws. They are holding the gearbox together and removing them may damage the gearbox severely.</p>	
3	<p>Pull the drive unit out carefully while pulling the motor cables out of the base rear.</p> <p> <b>Tip</b></p> <p>If the drive unit is hard to remove, insert two M3 screws and press out the drive unit.</p>  <p>xx1500002263</p>	 <p>xx1500002262</p>

**Refitting the axis-1 drive unit**

Use these procedures to refit the axis-1 drive unit.

Refitting the axis-1 drive unit

	Action	Note
1	<p>Make sure that:</p> <ul style="list-style-type: none"> <li>• all assembly surfaces are clean and undamaged.</li> <li>• the drive unit is clean and undamaged.</li> </ul>	

Continues on next page

## 4 Repair

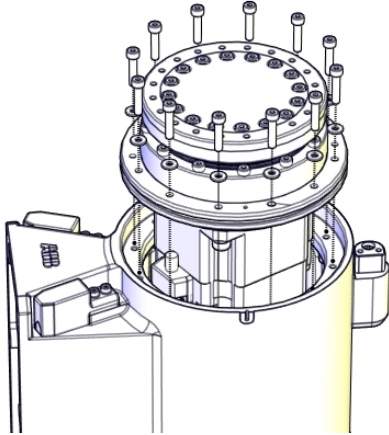

### 4.6.1 Replacing the axis-1 drive unit

Continued

	Action	Note
2	<p>Carefully insert the complete drive unit while pulling the motor cables out of the base rear.</p> <p> <b>CAUTION</b></p> <p>Do not mix axis-1 and axis-2 drive units. Always check the mark or label on the drive units before refitting.</p>	<p>Axis-1 drive unit: 3HAC055900-001</p> 
3	<p>Refit the screws and washers.</p>	<p>xx1500002262</p> <p>Screw: M4x20 (12 pcs) Tightening torque: 4.5 Nm Washer: 4.3x9x1 (12 pcs)</p>

### Refitting the arm system

	<p><b>Note</b></p>
<p>Two persons working together are required to perform this procedure.</p>	

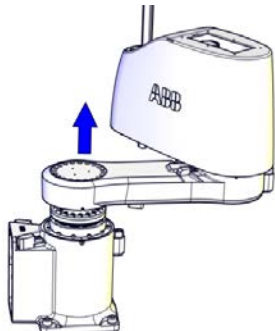
	Action	Note
1	<p> <b>Note</b></p> <p>Two persons working together are required to perform this step.</p> <p>Person 1: Hold the arm system.</p> <p>Person 2: Refit the screws that fasten the arm system to the base.</p>	
2	<p>Refit the whole arm system.</p> <p> <b>WARNING</b></p> <p>The arm system weights 16.4 kg. Support the gravity center properly.</p>	 <p>xx1500002261</p> <p>Screw: M4x20 (16 pcs) Tightening torque: 4.2 Nm Washer: 4.3x9x1.3 (16 pcs)</p>

Continues on next page

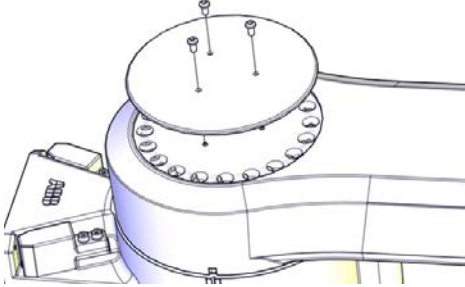

	Action	Note
3	 <b>CAUTION</b> Handle the main cable package with care. Minimum bending radius is approximately 10x the cable diameter.	
4	Refit the cover.	Lower arm cover: 3HAC056065-001  xx1500002259 Screw: M3x6 (3 pcs) Tightening torque: 1 Nm

Refitting the main cable to the base

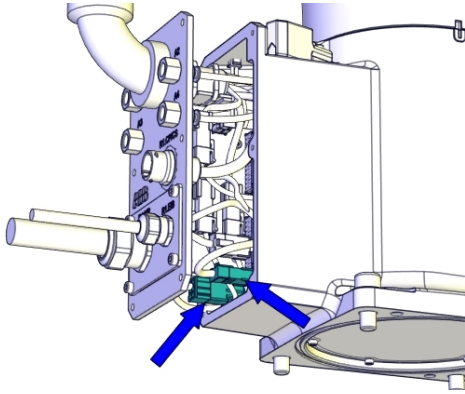
	Action	Note
1	Secure the main cable package with cable ties if needed.	
2	Reconnect the connectors. <ul style="list-style-type: none"> <li>• R2.MP1</li> <li>• R2.ME1</li> </ul>	 xx1500002188

Continues on next page

## 4 Repair

### 4.6.1 Replacing the axis-1 drive unit

Continued

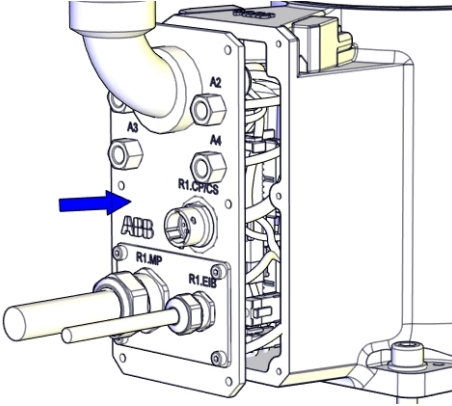
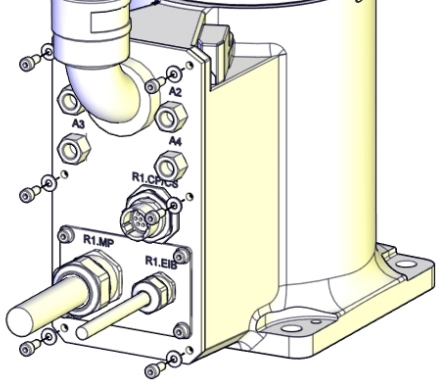
	Action	Note
3	Push the main cable package into place.	 <p>xx1500002204</p>
4	Refit the base cover with screws and washers.	 <p>xx1500002186</p> <p>Screws: M4x10 (6 pcs) Tightening torque: 2 Nm</p>

### Concluding procedure

	Action	Note
1	Recalibrate the robot.	Calibration is detailed in section <a href="#">Calibration on page 349</a> .
2	 <p><b>DANGER</b></p> <p>Make sure all safety requirements are met when performing the first test run. These are further detailed in the section "First test run may cause injury or damage" in <i>Safety manual for robot - Manipulator and IRC5 or OmniCore controller</i>.</p>	

## 4.6.2 Replacing the axis-2 drive unit

### Location of the axis-2 drive unit

The axis-2 drive unit is located as shown in the figure.

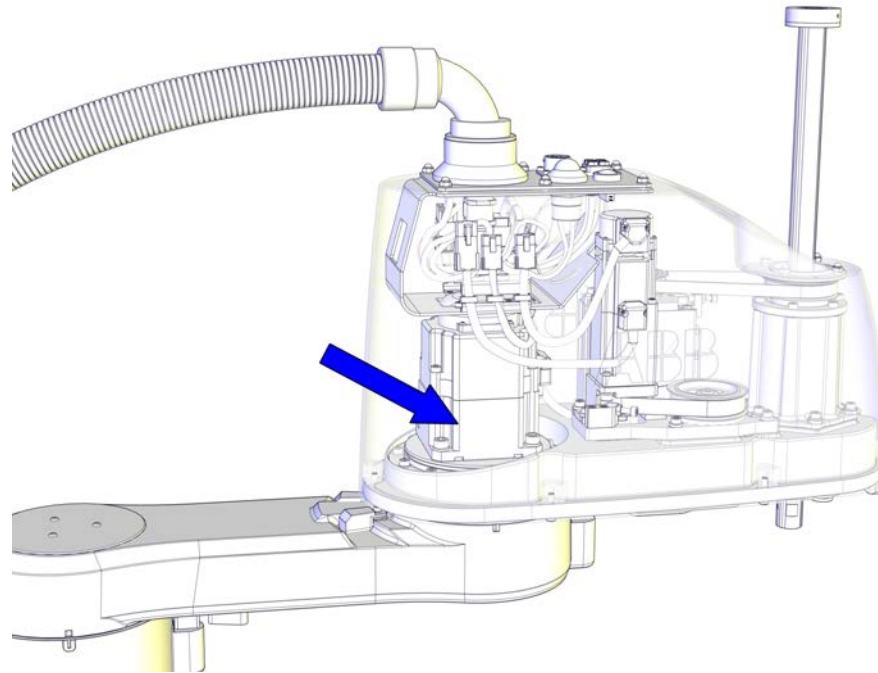

xx1500002214

### Required spare parts



#### Note

The spare part numbers that are listed in the table can be out of date. See the latest spare parts of the IRB 910SC via myABB Business Portal, [www.abb.com/myABB](http://www.abb.com/myABB).

Spare part	Article number	Note
Axis-2 drive unit	3HAC056153-001	Includes axis-2 gearbox, motor and motor adapter.
Upper cover unit	3HAC057615-001	Includes upper cover and cover flange.
Plate for upper arm cable harness	3HAC056086-001	Replace if damaged.

### Required tools and equipment

Equipment	Article number	Note
Standard toolkit	-	Content is defined in section <a href="#">Standard toolkit on page 392</a> .

*Continues on next page*

## 4 Repair

### 4.6.2 Replacing the axis-2 drive unit

*Continued*



#### Required consumables

Consumable	Article number	Note
Cable ties	-	

#### Removing the axis-2 drive unit

Use these procedures to remove the axis-2 drive unit.

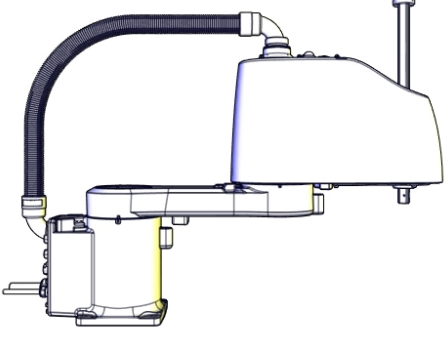



#### Preparations before removing the axis-2 drive unit

	Action	Note
1	Jog all axes to zero position.	 xx1500002227
2	 <b>DANGER</b> Turn off all: <ul style="list-style-type: none"><li>• electric power supply</li><li>• hydraulic pressure supply</li><li>• air pressure supply</li></ul> to the robot, before entering the robot working area.	

#### Removing the main cable package from the upper arm

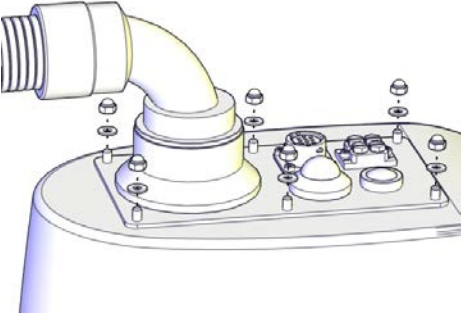
	Action	Note
1	 <b>DANGER</b> Make sure that all supplies for electrical power, hydraulic pressure, and air pressure are turned off.	

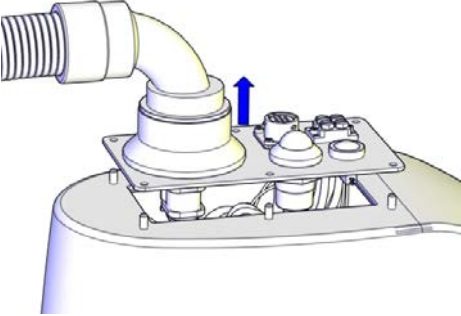
*Continues on next page*

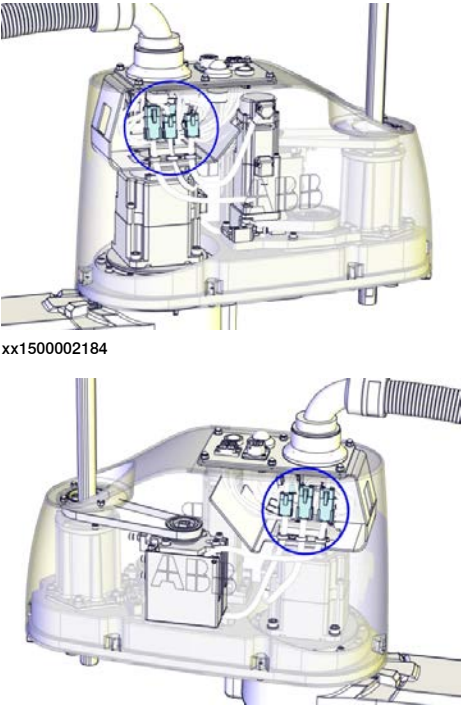
	Action	Note
2	Remove the dome nuts and washers.	 <p>xx1500002182</p>
3	<p>Carefully open the user interface plate and pull out the cable package.</p> <p> <b>CAUTION</b></p> <p>The plate cannot be removed completely until the connectors are disconnected, as shown in the following step.</p>	 <p>xx1500002183</p>
4	<p>Disconnect the connectors:</p> <ul style="list-style-type: none"> <li>• R2.MP2</li> <li>• R2.MP3</li> <li>• R2.MP4</li> <li>• R2.ME2</li> <li>• R2.ME3</li> <li>• R2.ME4</li> </ul> <p> <b>Tip</b></p> <p>Take photos of the connectors and cable position before disconnecting them, to have as a reference when reconnecting.</p>	 <p>xx1500002184</p> <p>xx1500002185</p>

Removing the upper arm



**Note**





Two persons working together are required to perform this procedure.

Continues on next page

## 4 Repair

### 4.6.2 Replacing the axis-2 drive unit

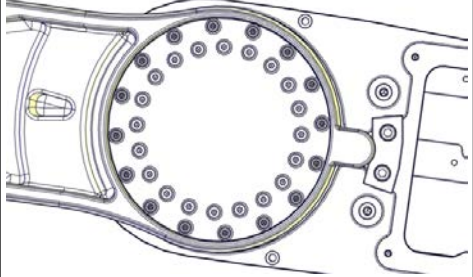
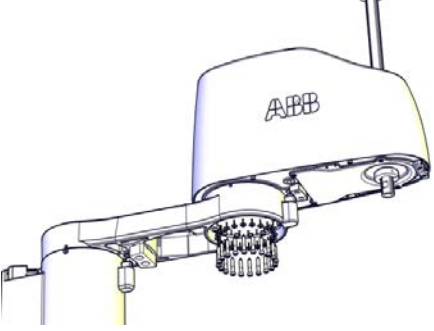

Continued

	Action	Note
1	 <b>DANGER</b> Make sure that all supplies for electrical power, hydraulic pressure, and air pressure are turned off.	
2	 <b>WARNING</b> The upper arm weights 13.2 kg. It may drop by the force of gravity when it is released from the lower arm. Make sure the weight of the upper arm body is properly supported.	
3	 <b>Note</b> Two persons working together are required to perform this step. Person 1: Hold the upper arm. Person 2: Remove the screws that fasten the upper arm to the lower arm.	
4	Remove the screws and washers.  <b>WARNING</b> Keep the twelve screws in the outer circle fitted. They hold the axis-2 motor flange on the lower arm.  <small>xx1500002257</small>	 <small>xx1500002256</small>
5	Remove the upper arm and lay it aside on a workbench.	

#### Removing the upper cover

	Action	Note
1	 <b>DANGER</b> Make sure that all supplies for electrical power, hydraulic pressure, and air pressure are turned off.	

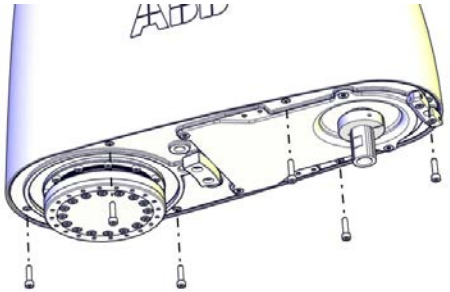
Continues on next page

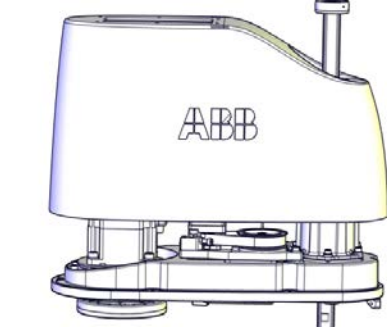
	Action	Note
2	<p> <b>WARNING</b></p> <p>Risk of tipping. Make sure the robot is well secured and that the upper arm is supported during the removal work.</p>	
3	Remove the screws.	 <p>xx1500002220</p>
4	<p> <b>WARNING</b></p> <p>The cover may be damaged due to improper shift. Keep the cover in position while removing the screws.</p>	
5	Lift out the upper cover carefully.	 <p>xx1500002221</p>

Removing the drive unit cables

	Action	Note
1	<p> <b>DANGER</b></p> <p>Make sure that all supplies for electrical power, hydraulic pressure, and air pressure are turned off.</p>	

## 4 Repair

### 4.6.2 Replacing the axis-2 drive unit

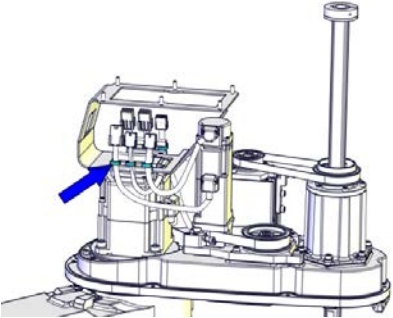

Continued

	Action	Note
2	<p>Cut the cable ties. Be careful not to damage the cabling.</p> <p> <b>Tip</b></p> <p>Take photos of the cable position before removing them, to have as a reference when refitting.</p>	 <p>xx1500002226</p>

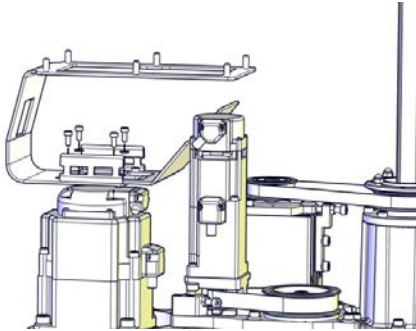
#### Removing the cable harness plate

	Action	Note
1	<p> <b>DANGER</b></p> <p>Make sure that all supplies for electrical power, hydraulic pressure, and air pressure are turned off.</p>	
2	Remove the screws and washers.	 <p>xx1500002228</p>
3	Remove the cable harness plate.	



#### Removing the axis-2 drive unit

	Action	Note
1	<p> <b>DANGER</b></p> <p>Make sure that all supplies for electrical power, hydraulic pressure, and air pressure are turned off.</p>	
2	<p> <b>WARNING</b></p> <p>There is a risk of tipping during the removal. Make sure the gravity center is well supported.</p>	

Continues on next page



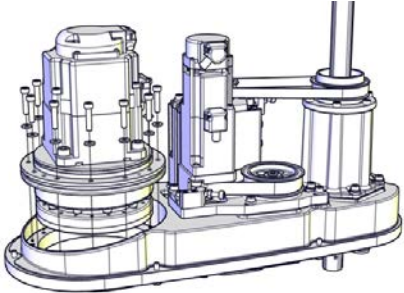

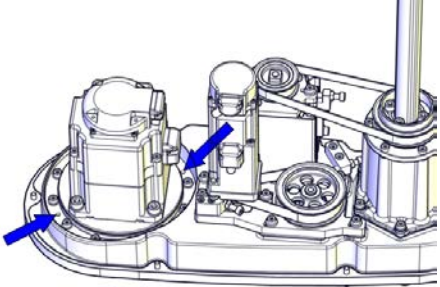
4.6.2 Replacing the axis-2 drive unit  
Continued

	Action	Note
3	<p>Remove drive unit screws and washers.</p> <p> <b>WARNING</b></p> <p>Pay attention to the screw positions and keep the others fitted. The other screws hold the gearbox together. Removing them can damage the gearbox severely.</p>	 <p>xx1500002496</p>
4	<p> <b>Tip</b></p> <p>If the drive unit is hard to be removed, insert two M2 screws to the press out holes and press out the drive unit.</p>	 <p>xx1500002498</p>

**Refitting the axis-2 drive unit**

Use these procedures to refit the axis-2 drive unit.

Refitting the axis-2 drive unit

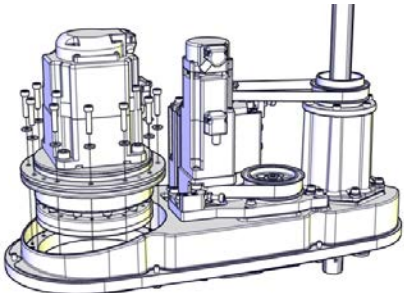
	Action	Note
1	<p>Make sure that:</p> <ul style="list-style-type: none"> <li>• all assembly surfaces are clean and undamaged.</li> <li>• the drive unit is clean and undamaged.</li> </ul>	
2	<p>Refit the axis-2 drive unit into the upper arm.</p> <p> <b>CAUTION</b></p> <p>Do not mix axis-1 and axis-2 drive units. Always check the mark or label on the drive units before refitting.</p> <p> <b>Note</b></p> <p>Make sure to refit the drive unit correctly oriented, that is, the motor connectors should point to the end where the ball screw spline unit is to be fitted.</p>	<p>Axis-2 drive unit: 3HAC056153-001</p>  <p>xx1500002496</p> <p>Screw: M4x25 (12 pcs) Tightening torque: 4.5 Nm Washer: 4.3x9x1 (12 pcs)</p>
3	<p>Refit the screws and washers.</p>	

Continues on next page

## 4 Repair

### 4.6.2 Replacing the axis-2 drive unit

*Continued*

#### Refitting the cable harness plate

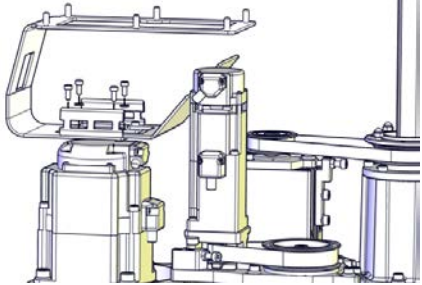

	Action	Note
1	Refit the cable harness plate.	 <p data-bbox="938 696 1050 719">xx1500002228</p> <p data-bbox="938 734 1235 833">Screw: M3x8 (4 pcs) Tightening torque: 1.5 Nm Washer: M3 (4 pcs)</p>
2	Secure with screws and washers.	

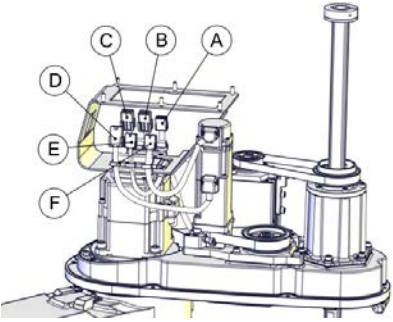
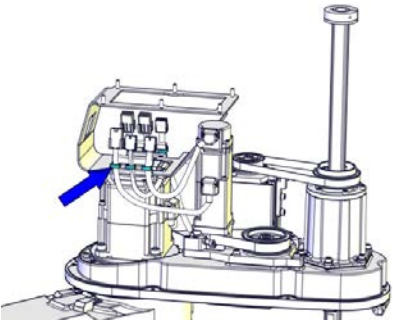
#### Securing the drive unit cables

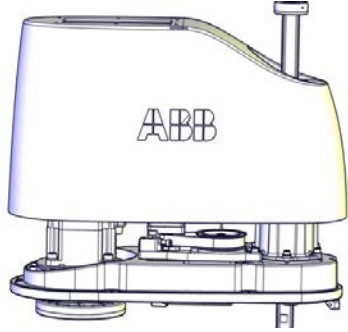

	Action	Note												
1	Put the drive unit cables in place.	 <p data-bbox="938 1292 1050 1314">xx1500003063</p> <table border="1" data-bbox="943 1330 1410 1603"> <tbody> <tr> <td data-bbox="943 1330 995 1375">A</td> <td data-bbox="995 1330 1410 1375">R2.ME3</td> </tr> <tr> <td data-bbox="943 1375 995 1420">B</td> <td data-bbox="995 1375 1410 1420">R2.MP2</td> </tr> <tr> <td data-bbox="943 1420 995 1464">C</td> <td data-bbox="995 1420 1410 1464">R2.MP3</td> </tr> <tr> <td data-bbox="943 1464 995 1509">D</td> <td data-bbox="995 1464 1410 1509">R2.MP4</td> </tr> <tr> <td data-bbox="943 1509 995 1554">E</td> <td data-bbox="995 1509 1410 1554">R2.ME2</td> </tr> <tr> <td data-bbox="943 1554 995 1599">F</td> <td data-bbox="995 1554 1410 1599">R2. ME4</td> </tr> </tbody> </table>	A	R2.ME3	B	R2.MP2	C	R2.MP3	D	R2.MP4	E	R2.ME2	F	R2. ME4
A	R2.ME3													
B	R2.MP2													
C	R2.MP3													
D	R2.MP4													
E	R2.ME2													
F	R2. ME4													
2	Secure the cables with cable ties. Do not tighten the ties too tight.	 <p data-bbox="938 1964 1050 1986">xx1500002226</p>												

*Continues on next page*

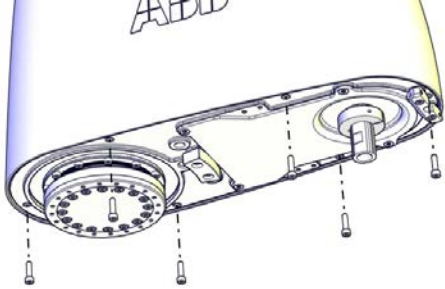
Refitting the upper cover

	Action	Note
1	Carefully put down the upper cover, avoiding any collision to the ball screw spline unit and drive units.	Upper cover unit: 3HAC057615-001  xx1500002221
2	 <b>Tip</b> Some of the screws are accessed from below. Make sure that the robot is properly fastened and hang out the upper arm from the workbench to access them.	
3	Refit the cover.	 xx1500002220 Screw: M4x16 (6 pcs) Tightening torque: 2 Nm

Refitting the upper arm

 <b>Note</b> Two persons working together are required to perform this procedure.		
	Action	Note
1	 <b>Note</b> Two persons working together are required to perform this step. Person 1: Hold the upper arm. Person 2: Refit the screws that fasten the upper arm to the lower arm.	

Continues on next page

## 4 Repair

### 4.6.2 Replacing the axis-2 drive unit

Continued

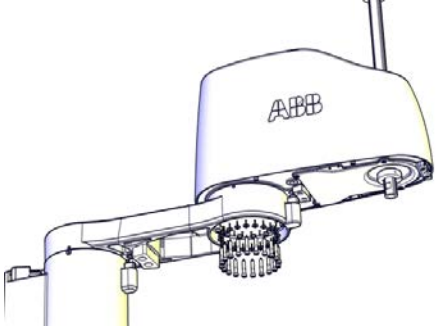
	Action	Note
2	Make sure the lower arm is secured. Lower the upper arm down onto the right place of the lower arm.	
3	Refit the upper arm screws and washers.	 <p data-bbox="940 741 1050 763">xx1500002256</p> <p data-bbox="940 779 1246 875">Screw: M4x20 (16 pcs) Tightening torque: 4.5 Nm Washer: 4.3x9x1.3 (16 pcs)</p>

### Refitting the main cable to the upper arm

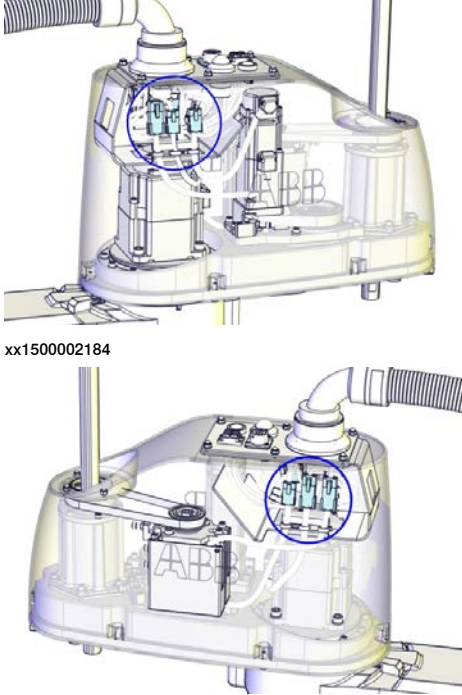
	Action	Note
1	Secure the main cable package with cable ties if needed.	
2	Reconnect the connectors. <ul style="list-style-type: none"> <li>• R2.MP2</li> <li>• R2.MP3</li> <li>• R2.MP4</li> <li>• R2.ME2</li> <li>• R2.ME3</li> <li>• R2.ME4</li> </ul>	 <p data-bbox="940 1413 1050 1435">xx1500002184</p> <p data-bbox="940 1783 1050 1805">xx1500002185</p>

Continues on next page

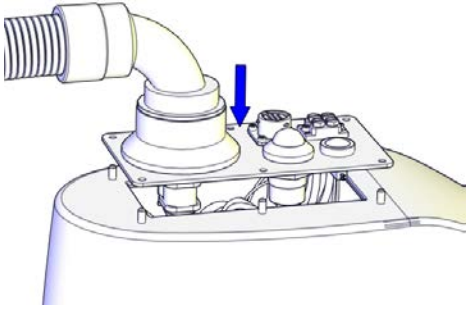
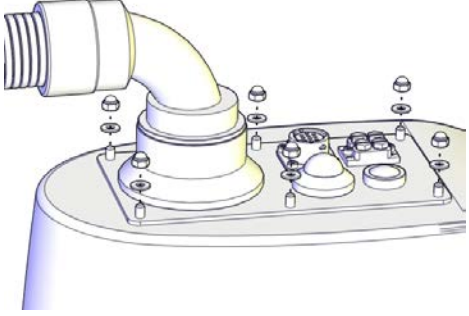
	Action	Note
3	Push the main cable package into place.	 <p>xx1500002207</p>
4	Refit the user interface plate.	 <p>xx1500002182</p> <p>Dome nut: M4 (6 pcs) Tightening torque: 2 Nm Washer, 6 pcs</p>

Concluding procedure

	Action	Note
1	Recalibrate the robot.	Calibration is detailed in section <a href="#">Calibration on page 349</a> .
2	 <p><b>DANGER</b></p> <p>Make sure all safety requirements are met when performing the first test run. These are further detailed in the section "First test run may cause injury or damage" in <i>Safety manual for robot - Manipulator and IRC5 or OmniCore controller</i>.</p>	

## 4 Repair

### 4.6.3 Replacing the axis-3 drive unit

### 4.6.3 Replacing the axis-3 drive unit

#### Location of the axis-3 drive unit

The axis-3 drive unit is located as shown in the figure.

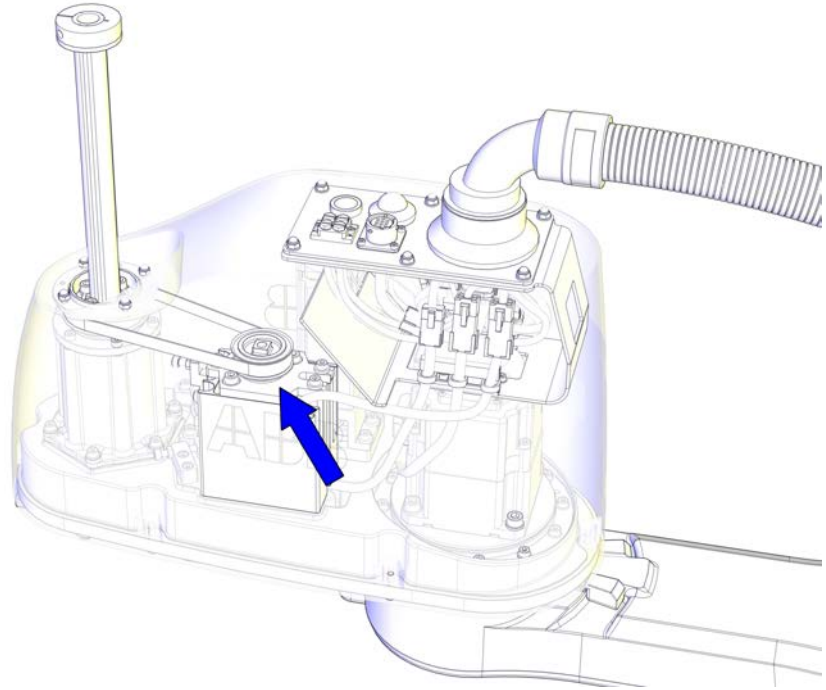

xx150002219

#### Required spare parts



#### Note

The spare part numbers that are listed in the table can be out of date. See the latest spare parts of the IRB 910SC via myABB Business Portal, [www.abb.com/myABB](http://www.abb.com/myABB).

Spare part	Article number	Note
Axis-3 drive unit	3HAC056111-001	Includes axis-3 gearbox, motor and motor adapter.
Upper cover unit	3HAC057615-001	Includes upper cover and cover flange.
Plain washer	3HAC056937-001	Replace if damaged.
Axis-3 drive unit housing	3HAC055184-001	Replace if damaged.

#### Required tools and equipment

Equipment	Article number	Note
Standard toolkit	-	The content is defined in the section <a href="#">Standard toolkit on page 392</a> .

Continues on next page

4.6.3 Replacing the axis-3 drive unit

*Continued*

Equipment	Article number	Note
Sonic tensiometer	-	Used for measuring the timing belt tension.
Dynamometer	-	Used for measuring the timing belt tension.

**Required consumables**

Consumable	Article number	Note
Cable ties	-	

**Removing the axis-3 drive unit**

Use these procedures to remove the axis-3 drive unit.

**Preparations before removing the axis-3 drive unit**

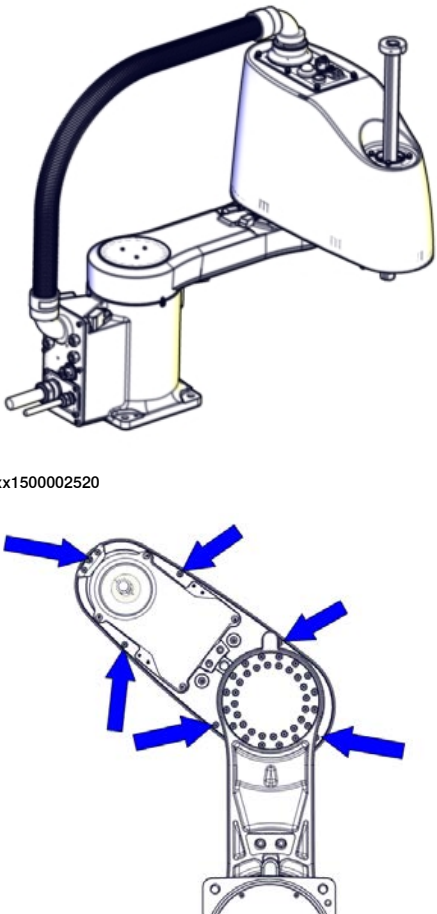
Action	Note
1 Jog axis 2 to access the cover screws.	 <p>xx1500002520</p> <p>xx1500002782</p>

*Continues on next page*



## 4 Repair

### 4.6.3 Replacing the axis-3 drive unit

Continued

	Action	Note
2	 <b>DANGER</b> Turn off all: <ul style="list-style-type: none"><li>• electric power supply</li><li>• hydraulic pressure supply</li><li>• air pressure supply</li></ul> to the robot, before entering the robot working area.	

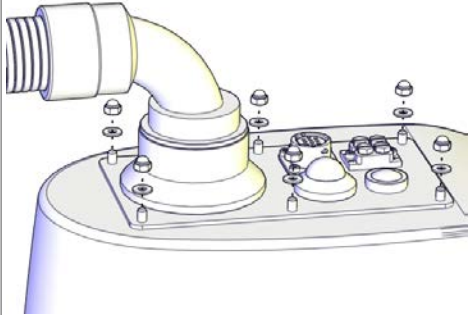
#### Removing the main cable package from the upper arm

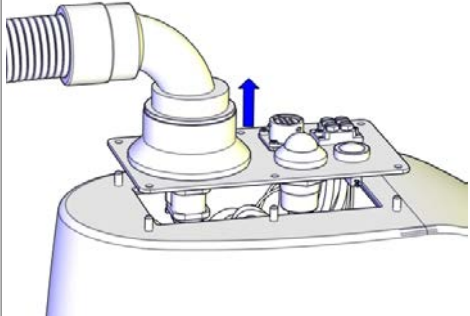

	Action	Note
1	 <b>DANGER</b> Make sure that all supplies for electrical power, hydraulic pressure, and air pressure are turned off.	
2	Remove the dome nuts and washers.	 xx1500002182
3	Carefully open the user interface plate and pull out the cable package.  <b>CAUTION</b> The plate cannot be removed completely until the connectors are disconnected, as shown in the following step.	 xx1500002183

Continues on next page

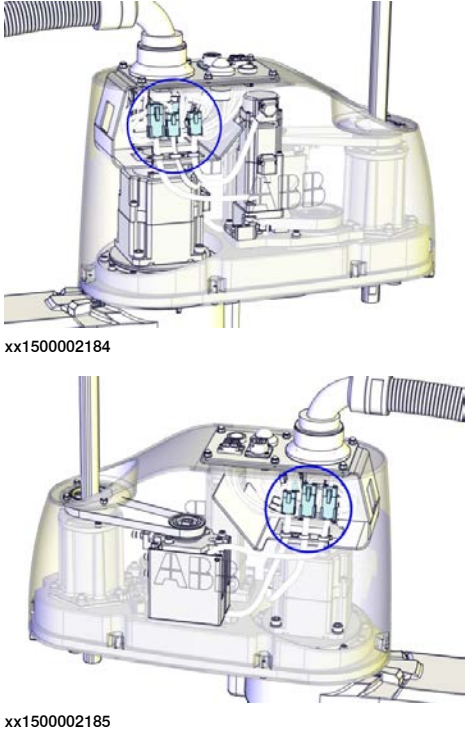

	Action	Note
4	<p>Disconnect the connectors:</p> <ul style="list-style-type: none"> <li>• R2.MP2</li> <li>• R2.MP3</li> <li>• R2.MP4</li> <li>• R2.ME2</li> <li>• R2.ME3</li> <li>• R2.ME4</li> </ul> <p> <b>Tip</b></p> <p>Take photos of the connectors and cable position before disconnecting them, to have as a reference when reconnecting.</p>	 <p>xx1500002184</p> <p>xx1500002185</p>

Removing the upper cover

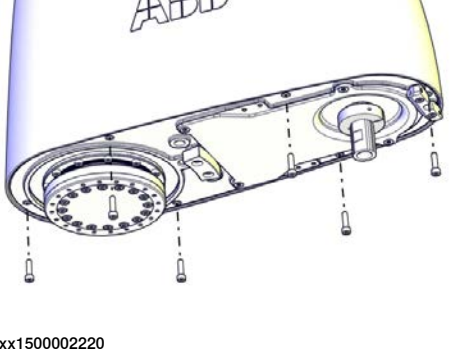
	Action	Note
1	<p> <b>DANGER</b></p> <p>Make sure that all supplies for electrical power, hydraulic pressure, and air pressure are turned off.</p>	
2	<p> <b>WARNING</b></p> <p>Risk of tipping. Make sure the robot is well secured and that the upper arm is supported during the removal work.</p>	
3	<p>Remove the screws.</p>	 <p>xx1500002220</p>

Continues on next page



## 4 Repair

### 4.6.3 Replacing the axis-3 drive unit

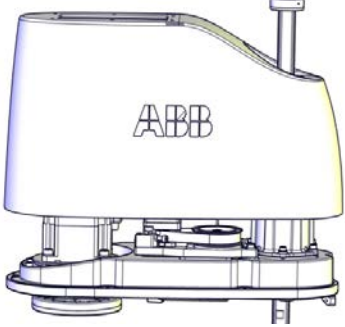
Continued

	Action	Note
4	 <b>WARNING</b> The cover may be damaged due to improper shift. Keep the cover in position while removing the screws.	
5	Lift out the upper cover carefully.	 <p>xx1500002221</p>

#### Removing the drive unit cables

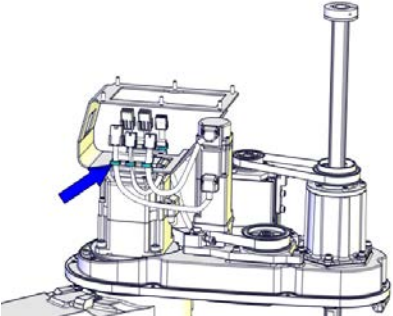
	Action	Note
1	 <b>DANGER</b> Make sure that all supplies for electrical power, hydraulic pressure, and air pressure are turned off.	
2	Cut the cable ties. Be careful not to damage the cabling.   <b>Tip</b> Take photos of the cable position before removing them, to have as a reference when refitting.	 <p>xx1500002226</p>



#### Removing the axis-3 timing belt

	Action	Note
1	 <b>DANGER</b> Make sure that all supplies for electrical power, hydraulic pressure, and air pressure are turned off.	

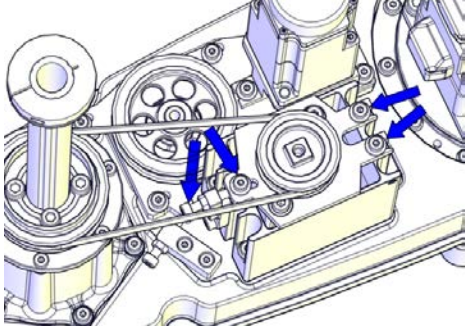
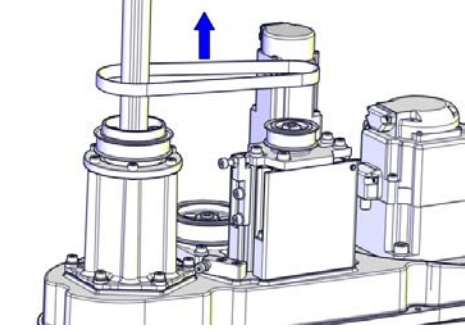
Continues on next page

	Action	Note
2	 <b>WARNING</b> Risk of tipping. Make sure the gravity center is well supported.	
3	Loosen the screws and move the axis-3 drive unit upwards to slacken the timing belt.	 <p>xx1500002229</p>
4	Remove the timing belt.	 <p>xx1500002230</p>

Removing the axis-3 housing and axis-3 drive unit

	Action	Note
1	 <b>DANGER</b> Make sure that all supplies for electrical power, hydraulic pressure, and air pressure are turned off.	
2	 <b>WARNING</b> Risk of tipping. Make sure the gravity center is well supported.	

Continues on next page

## 4 Repair

### 4.6.3 Replacing the axis-3 drive unit

*Continued*

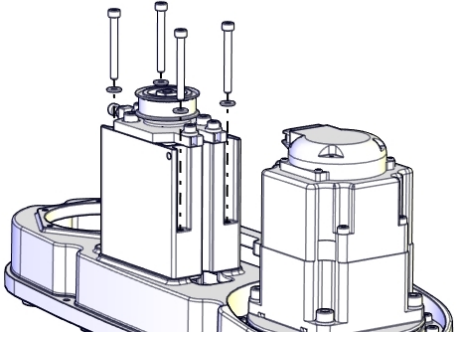
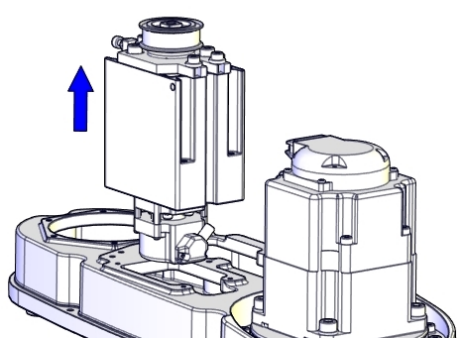
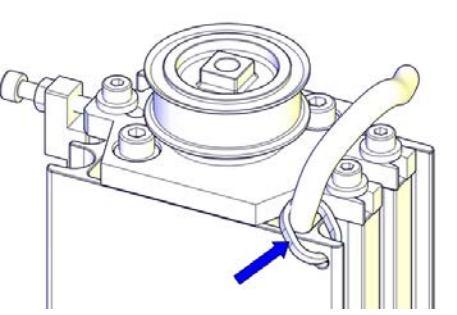
	Action	Note
3	Remove the screws and washers.	 <p>xx1500002810</p>
4	Lift out the axis-3 housing and drive unit.	 <p>xx1500002238</p>
5	Cut the cable tie. Be careful not to damage the cabling.	 <p>xx1500002815</p>

*Continues on next page*

4.6.3 Replacing the axis-3 drive unit  
Continued

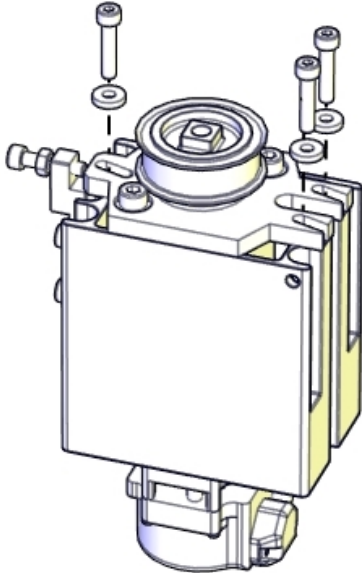
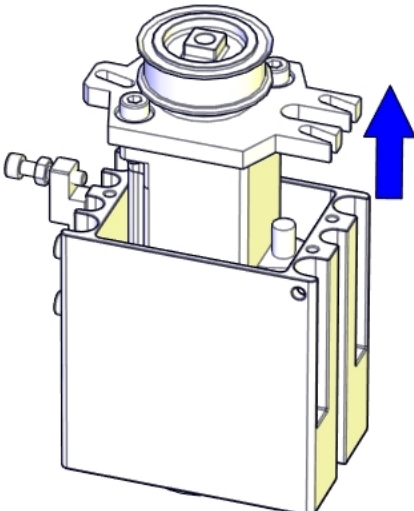
	Action	Note
6	<p>Remove the screws.</p> <p> <b>WARNING</b></p> <p>Do not remove the other screws. They hold the gearbox together. Removing them can damage the gearbox severely.</p>	 <p>xx1500002797</p>
7	<p>Lift out the axis-3 drive unit carefully.</p>	 <p>xx1500002239</p>

Continues on next page

## 4 Repair



### 4.6.3 Replacing the axis-3 drive unit

*Continued*

#### Refitting the axis-3 drive unit

Use these procedures to refit the axis-3 drive unit.

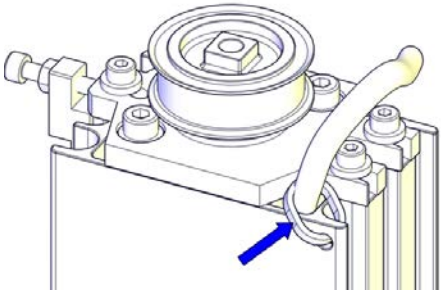
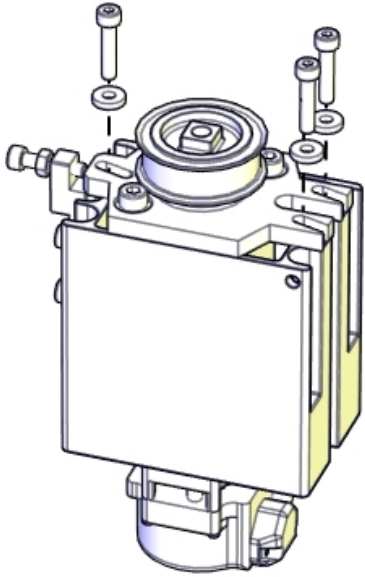
#### Refitting the axis-3 housing and axis-3 drive unit

	Action	Note
1	<p>Refit the drive unit with one cabling coming out from the upside and the other coming out from the downside.</p> <p> <b>Note</b></p> <p>Make sure to refit the drive unit correctly oriented with the lugs of the drive unit bracket as a reference.</p>	<p>Axis-3 drive unit: 3HAC056111-001 Axis-3 drive unit housing: 3HAC055184-001</p>
2	<p>Secure the upper cabling with a cable tie. Do not tighten the tie too tight.</p>	 <p>xx1500002815</p>
3	<p>Refit drive unit screws and washers just enough to still be able to move the drive unit.</p>	 <p>xx1500002797</p> <p>Screw: M4x20 (3 pcs) Tightening torque: 4.5 Nm Washer (3HAC056937-001, 3 pcs)</p> <p> <b>Note</b></p> <p>Only use specified washers, never replace them with other washers.</p>

*Continues on next page*

4.6.3 Replacing the axis-3 drive unit

*Continued*

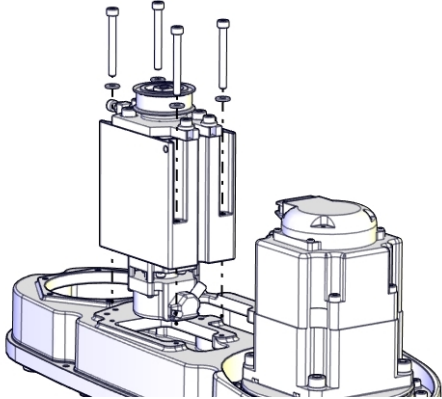
	Action	Note
4	Refit the housing with drive unit.	 <p>xx1500002798</p> <p>Screw: M4x40 (4 pcs) Tightening torque: 3.5 Nm Washer: M4 (4 pcs)</p>

Refitting the axis-3 timing belt

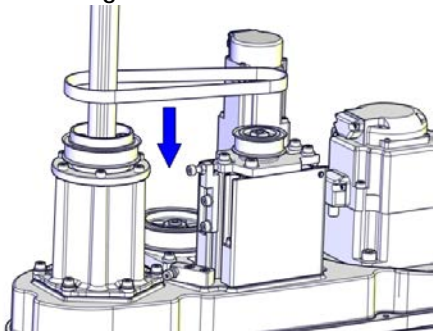
	Action	Note
1	<p>Make sure that:</p> <ul style="list-style-type: none"> <li>• all assembly surfaces are clean and undamaged.</li> <li>• the drive unit is clean and undamaged.</li> </ul>	
2	Refit axis-3 timing belt. Ensure that the belt runs correctly in the grooves.	<p>Axis-3 timing belt: 3HAC055209-001</p>  <p>xx1500002789</p>

*Continues on next page*

## 4 Repair

### 4.6.3 Replacing the axis-3 drive unit

Continued

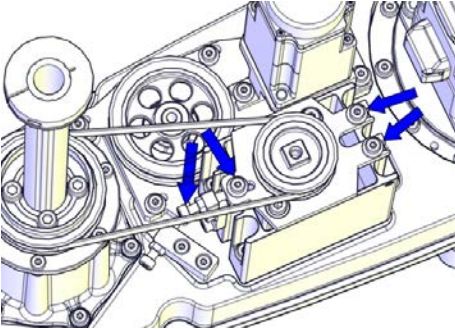
	Action	Note
3	Fasten the screws little by little while using a dynamometer to measure the belt tension until a proper belt tension is achieved.	 <p data-bbox="943 645 1050 663">xx150002229</p> <p data-bbox="943 680 1374 707">Belt tension: <math>F = 34 \text{ N}</math> (Recommended)</p> <p data-bbox="943 714 1155 741">Belt tension range:</p> <p data-bbox="943 748 1406 831">21.8 N to 24.9 N (for used timing belt, which has been installed and used for more than 24 hours)</p> <p data-bbox="943 837 1326 864">31.1 to 34.2 N (for new timing belt)</p>

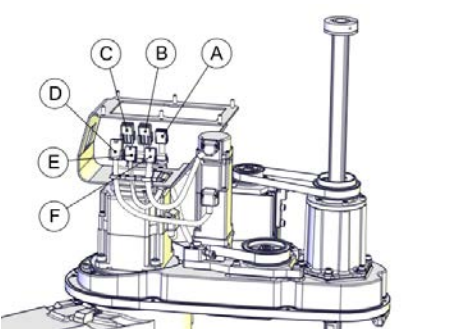
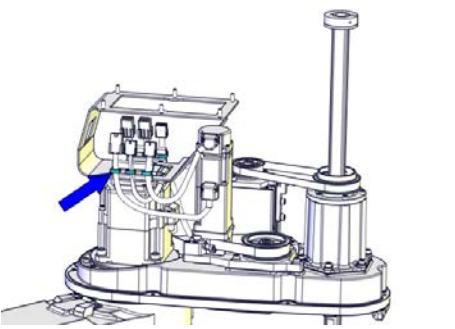

### Securing the drive unit cables

	Action	Note												
1	Put the drive unit cables in place.	 <p data-bbox="943 1323 1050 1341">xx150003063</p> <table border="1" data-bbox="943 1361 1399 1637"> <tbody> <tr> <td data-bbox="943 1361 991 1388">A</td> <td data-bbox="995 1361 1399 1388">R2.ME3</td> </tr> <tr> <td data-bbox="943 1395 991 1422">B</td> <td data-bbox="995 1395 1399 1422">R2.MP2</td> </tr> <tr> <td data-bbox="943 1429 991 1456">C</td> <td data-bbox="995 1429 1399 1456">R2.MP3</td> </tr> <tr> <td data-bbox="943 1462 991 1489">D</td> <td data-bbox="995 1462 1399 1489">R2.MP4</td> </tr> <tr> <td data-bbox="943 1496 991 1523">E</td> <td data-bbox="995 1496 1399 1523">R2.ME2</td> </tr> <tr> <td data-bbox="943 1529 991 1556">F</td> <td data-bbox="995 1529 1399 1556">R2. ME4</td> </tr> </tbody> </table>	A	R2.ME3	B	R2.MP2	C	R2.MP3	D	R2.MP4	E	R2.ME2	F	R2. ME4
A	R2.ME3													
B	R2.MP2													
C	R2.MP3													
D	R2.MP4													
E	R2.ME2													
F	R2. ME4													
2	Secure the cables with cable ties. Do not tighten the ties too tight.	 <p data-bbox="943 2004 1050 2022">xx150002226</p>												

Continues on next page

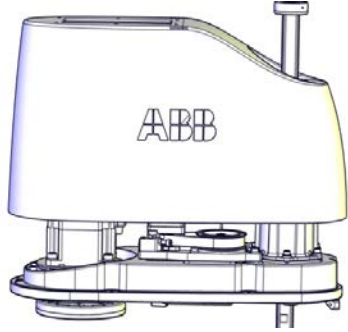

Refitting the upper cover

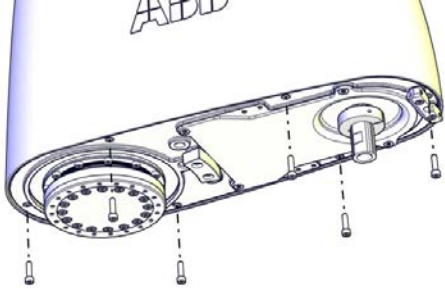
	Action	Note
1	Carefully put down the upper cover, avoiding any collision to the ball screw spline unit and drive units.	Upper cover unit: 3HAC057615-001  xx1500002221
2	 <b>Tip</b> Some of the screws are accessed from below. Make sure that the robot is properly fastened and hang out the upper arm from the workbench to access them.	
3	Refit the cover.	 xx1500002220 Screw: M4x16 (6 pcs) Tightening torque: 2 Nm

Refitting the main cable to the upper arm

	Action	Note
1	Secure the main cable package with cable ties if needed.	

Continues on next page

## 4 Repair

### 4.6.3 Replacing the axis-3 drive unit

Continued

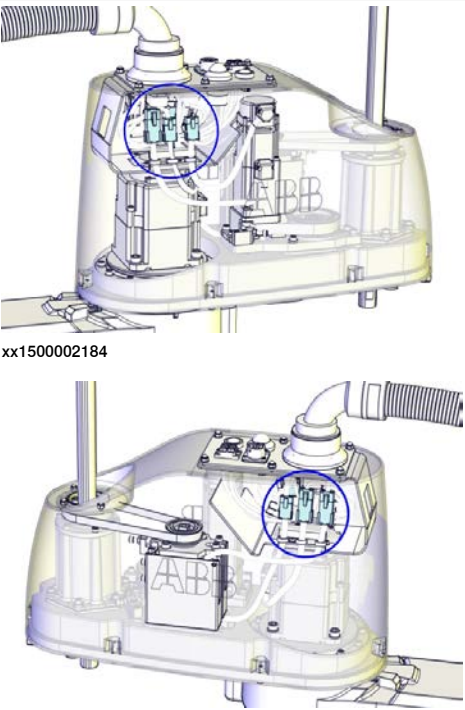
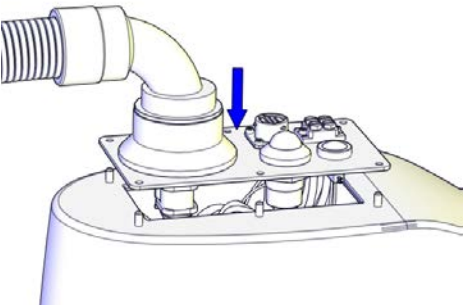
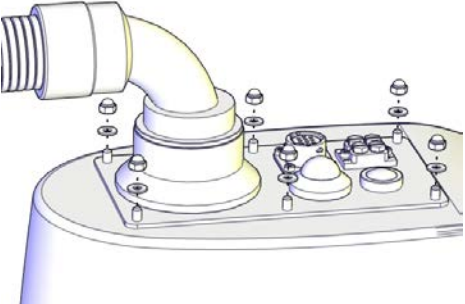
	Action	Note
2	<p>Reconnect the connectors.</p> <ul style="list-style-type: none"><li>• R2.MP2</li><li>• R2.MP3</li><li>• R2.MP4</li><li>• R2.ME2</li><li>• R2.ME3</li><li>• R2.ME4</li></ul>	 <p>xx1500002184</p> <p>xx1500002185</p>
3	<p>Push the main cable package into place.</p>	 <p>xx1500002207</p>
4	<p>Refit the user interface plate.</p>	 <p>xx1500002182</p> <p>Dome nut: M4 (6 pcs) Tightening torque: 2 Nm Washer, 6 pcs</p>

Continues on next page

## Concluding procedure

	Action	Note
1	Recalibrate the robot.	Calibration is detailed in section <a href="#">Calibration on page 349</a> .
2	 <b>DANGER</b> Make sure all safety requirements are met when performing the first test run. These are further detailed in the section "First test run may cause injury or damage" in <i>Safety manual for robot - Manipulator and IRC5 or OmniCore controller</i> .	

## 4 Repair

### 4.6.4 Replacing the axis-4 drive unit

#### 4.6.4 Replacing the axis-4 drive unit

##### Location of the axis-4 drive unit

The axis-4 drive unit is located as shown in the figure.

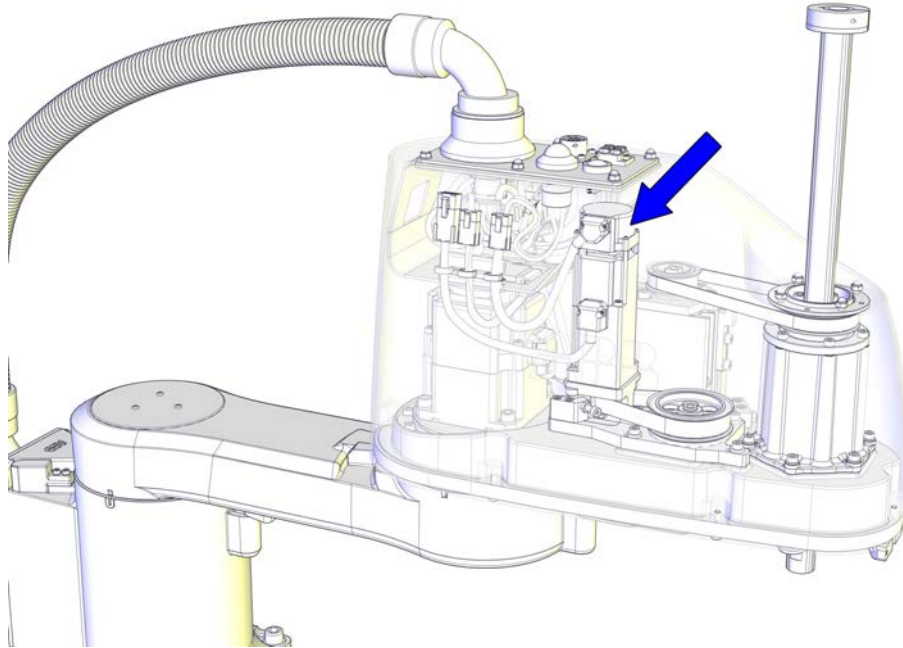

xx1500002215

##### Required spare parts



##### Note

The spare part numbers that are listed in the table can be out of date. See the latest spare parts of the IRB 910SC via myABB Business Portal, [www.abb.com/myABB](http://www.abb.com/myABB).

Spare part	Article number	Note
Axis-4 drive unit	3HAC056112-001	Includes axis-4 gearbox, motor and motor adapter.
Upper cover unit	3HAC057615-001	Includes upper cover and cover flange.
Plain washer	3HAC056937-001	Replace if damaged.

##### Required tools and equipment

Equipment	Article number	Note
Standard toolkit	-	The content is defined in the section <a href="#">Standard toolkit on page 392</a> .
Sonic tensiometer	-	Used for measuring the timing belt tension.

*Continues on next page*

4.6.4 Replacing the axis-4 drive unit

*Continued*

Equipment	Article number	Note
Dynamometer	-	Used for measuring the timing belt tension.

**Required consumables**

Consumable	Article number	Note
Cable ties	-	

**Removing the axis-4 drive unit**

Use these procedures to remove the axis-4 drive unit.

**Preparations before removing the axis-4 drive unit**

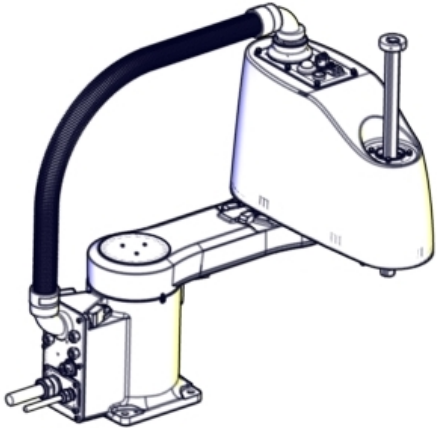
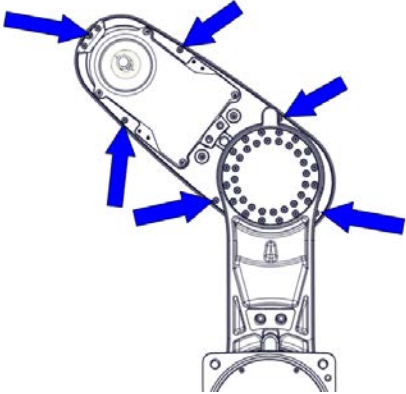
Action	Note
1 Jog axis 2 to access the cover screws.	 <p>xx1500002520</p>  <p>xx1500002782</p>

*Continues on next page*



## 4 Repair

### 4.6.4 Replacing the axis-4 drive unit

Continued

	Action	Note
2	 <b>DANGER</b> Turn off all: <ul style="list-style-type: none"><li>• electric power supply</li><li>• hydraulic pressure supply</li><li>• air pressure supply</li></ul> to the robot, before entering the robot working area.	

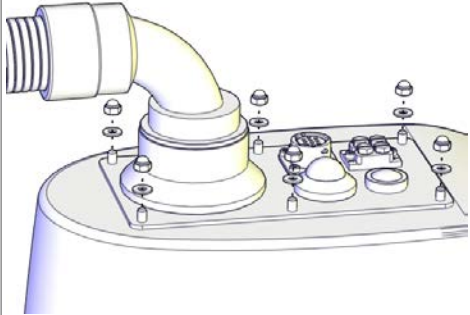
#### Removing the main cable package from the upper arm

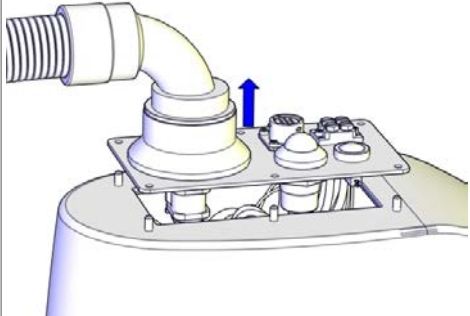

	Action	Note
1	 <b>DANGER</b> Make sure that all supplies for electrical power, hydraulic pressure, and air pressure are turned off.	
2	Remove the dome nuts and washers.	 xx1500002182
3	Carefully open the user interface plate and pull out the cable package.  <b>CAUTION</b> The plate cannot be removed completely until the connectors are disconnected, as shown in the following step.	 xx1500002183

Continues on next page

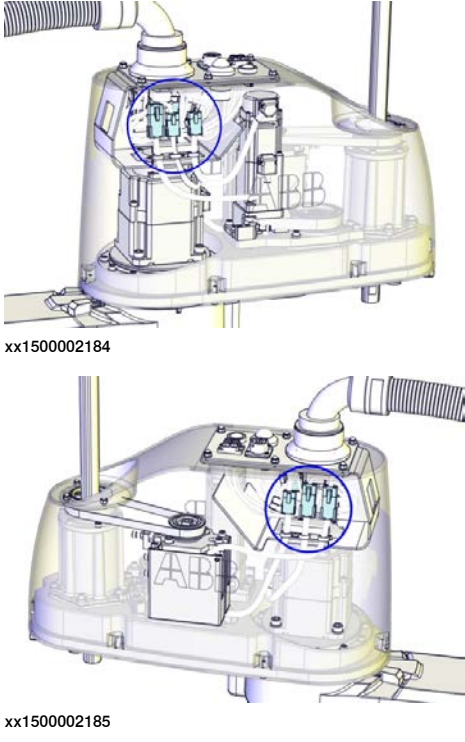
4.6.4 Replacing the axis-4 drive unit  
Continued

	Action	Note
4	<p>Disconnect the connectors:</p> <ul style="list-style-type: none"> <li>• R2.MP2</li> <li>• R2.MP3</li> <li>• R2.MP4</li> <li>• R2.ME2</li> <li>• R2.ME3</li> <li>• R2.ME4</li> </ul> <p> <b>Tip</b></p> <p>Take photos of the connectors and cable position before disconnecting them, to have as a reference when reconnecting.</p>	 <p>xx1500002184</p> <p>xx1500002185</p>

Removing the upper cover

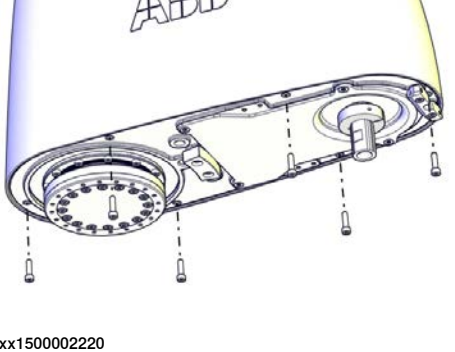
	Action	Note
1	<p> <b>DANGER</b></p> <p>Make sure that all supplies for electrical power, hydraulic pressure, and air pressure are turned off.</p>	
2	<p> <b>WARNING</b></p> <p>Risk of tipping. Make sure the robot is well secured and that the upper arm is supported during the removal work.</p>	
3	<p>Remove the screws.</p>	 <p>xx1500002220</p>

Continues on next page



## 4 Repair

### 4.6.4 Replacing the axis-4 drive unit

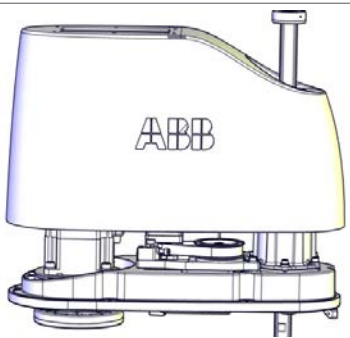
Continued

	Action	Note
4	 <b>WARNING</b> The cover may be damaged due to improper shift. Keep the cover in position while removing the screws.	
5	Lift out the upper cover carefully.	 xx1500002221

### Removing the drive unit cables

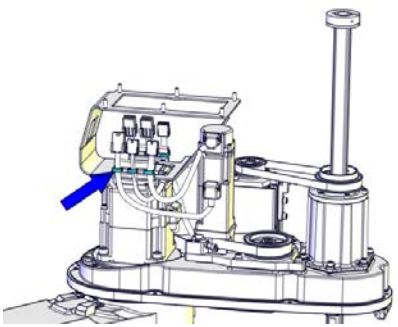

	Action	Note
1	 <b>DANGER</b> Make sure that all supplies for electrical power, hydraulic pressure, and air pressure are turned off.	
2	Cut the cable ties. Be careful not to damage the cabling.   <b>Tip</b> Take photos of the cable position before removing them, to have as a reference when refitting.	 xx1500002226

### Removing the lower cover

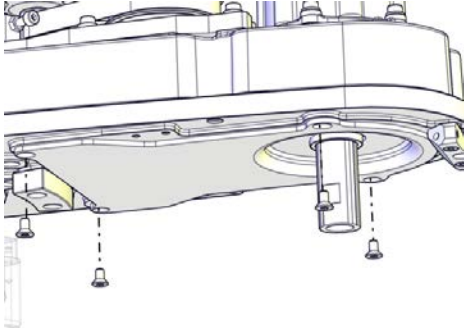

	Action	Note
1	 <b>DANGER</b> Make sure that all supplies for electrical power, hydraulic pressure, and air pressure are turned off.	

Continues on next page

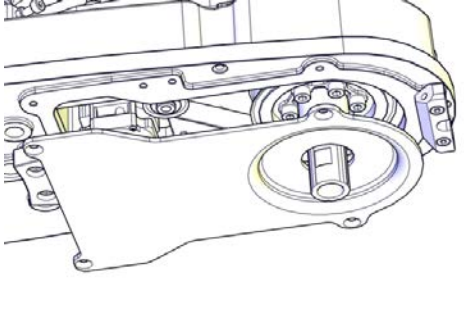

	Action	Note
2	Remove the screws.	 <p>xx1500002785</p>
3	Remove the cover.  <b>Tip</b> If only working with lower axis-4 timing belt, no need to remove the stop block of ball screw spline unit before removing the lower cover.	 <p>xx1500002225</p>

Removing the axis-4 drive unit and upper timing belt

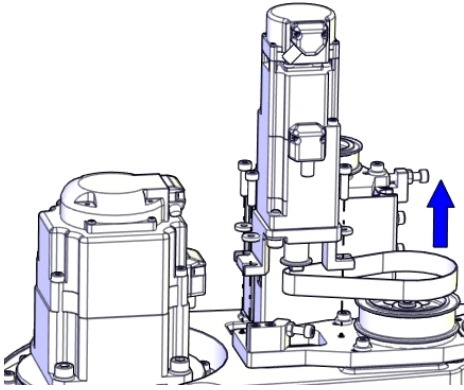
	Action	Note
1	 <b>DANGER</b> Make sure that all supplies for electrical power, hydraulic pressure, and air pressure are turned off.	
2	 <b>WARNING</b> Risk of tipping. Make sure the gravity center is well supported.	
3	Loosen the screws and move the axis-4 drive unit upwards to slacken the upper axis-4 timing belt.	 <p>xx1500002233</p>

Continues on next page

## 4 Repair

### 4.6.4 Replacing the axis-4 drive unit

*Continued*

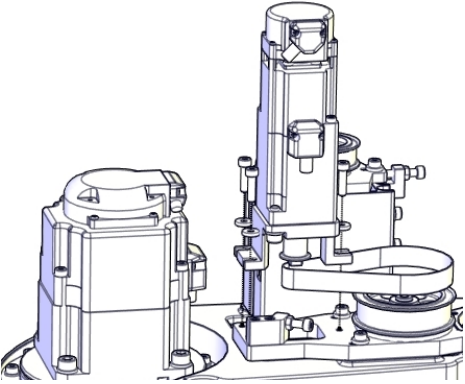
	Action	Note
4	Remove the drive unit and timing belt.	 <p>xx1500002234</p>

#### Refitting the axis-4 drive unit

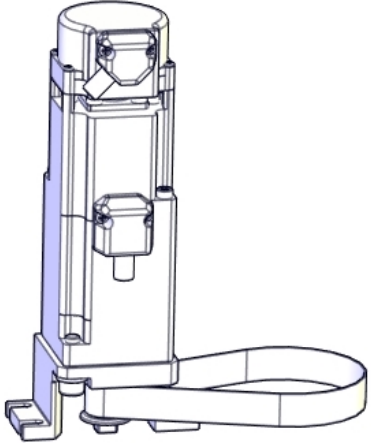

Use these procedures to refit the axis-4 drive unit.

#### Refitting the axis-4 drive unit and upper timing belt

	Action	Note
1	Make sure that: <ul style="list-style-type: none"> <li>• all assembly surfaces are clean and undamaged.</li> <li>• the drive unit is clean and undamaged.</li> </ul>	
2	Place the timing belt.	Axis-4 drive unit: 3HAC056112-001 Upper axis-4 timing belt: 3HAC055206-001  <p>xx1500002801</p>

*Continues on next page*

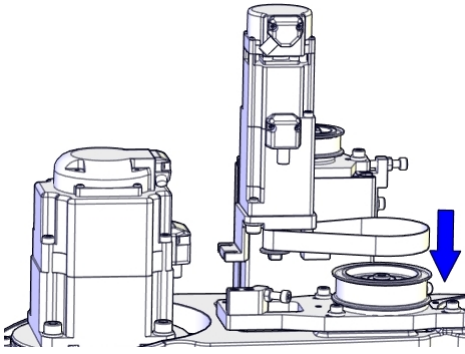
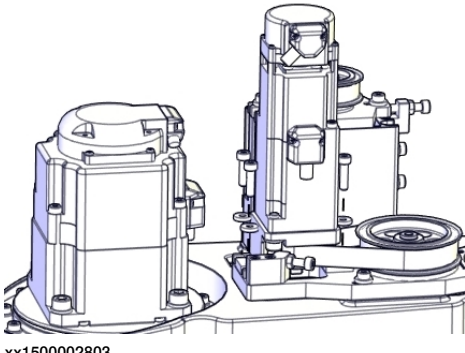
4.6.4 Replacing the axis-4 drive unit  
Continued

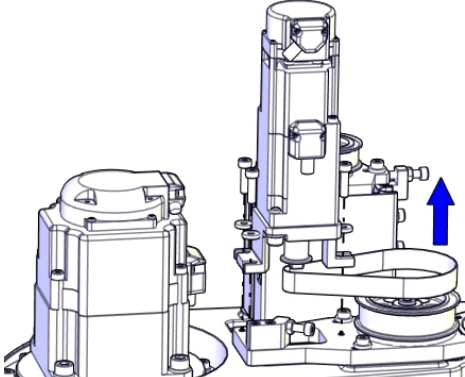
	Action	Note
3	<p>Refit the drive unit and timing belt.</p> <p> <b>Note</b></p> <p>Make sure to refit the drive unit with motor connectors pointing against axis-3 drive unit.</p>	 <p>xx1500002802</p>
4	<p>Refit screws and washers just enough to still be able to move the drive unit upwards.</p>	 <p>xx1500002803</p> <p>Screw: M4x16 (3 pcs) Washer (3HAC056937-001, 3 pcs)</p> <p> <b>Note</b></p> <p>Only use specified washers, never replace them with other washers.</p>
5	<p>Fasten the screws little by little while using a dynamometer to measure the belt tension until a proper belt tension is achieved.</p>	 <p>xx1500002233</p> <p>Belt tension: <math>F = 37 \text{ N}</math> (Recommended) Belt tension range: 24.1 N to 27.6 N (for used timing belt, which has been installed and used for more than 24 hours) 34.5 N to 37.9 N (for new timing belt)</p>

Continues on next page

## 4 Repair

### 4.6.4 Replacing the axis-4 drive unit

Continued

#### Securing the drive unit cables

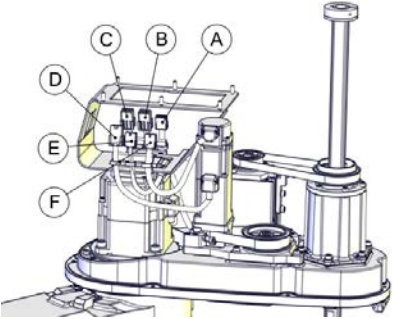
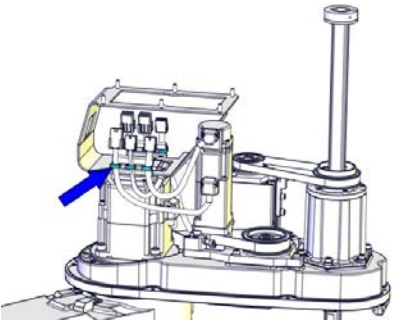
	Action	Note												
1	Put the drive unit cables in place.	 <p>xx1500003063</p> <table border="1" data-bbox="943 734 1406 1010"> <tbody> <tr> <td>A</td> <td>R2.ME3</td> </tr> <tr> <td>B</td> <td>R2.MP2</td> </tr> <tr> <td>C</td> <td>R2.MP3</td> </tr> <tr> <td>D</td> <td>R2.MP4</td> </tr> <tr> <td>E</td> <td>R2.ME2</td> </tr> <tr> <td>F</td> <td>R2.ME4</td> </tr> </tbody> </table>	A	R2.ME3	B	R2.MP2	C	R2.MP3	D	R2.MP4	E	R2.ME2	F	R2.ME4
A	R2.ME3													
B	R2.MP2													
C	R2.MP3													
D	R2.MP4													
E	R2.ME2													
F	R2.ME4													
2	Secure the cables with cable ties. Do not tighten the ties too tight.	 <p>xx1500002226</p>												

#### Refitting the upper cover

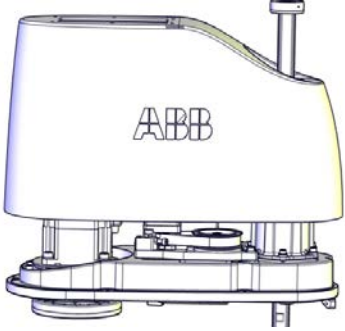
	Action	Note
1	Carefully put down the upper cover, avoiding any collision to the ball screw spline unit and drive units.	<p>Upper cover unit: 3HAC057615-001</p>  <p>xx1500002221</p>

Continues on next page

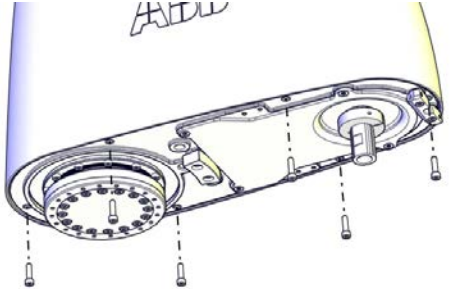
	Action	Note
2	 <b>Tip</b> Some of the screws are accessed from below. Make sure that the robot is properly fastened and hang out the upper arm from the workbench to access them.	
3	Refit the cover.	 <p>xx1500002220</p> <p>Screw: M4x16 (6 pcs) Tightening torque: 2 Nm</p>

Refitting the lower cover

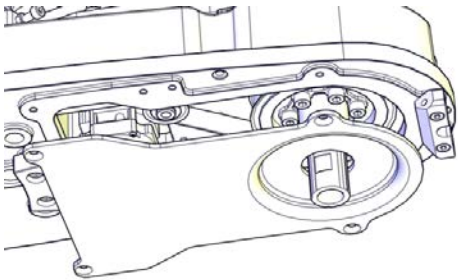
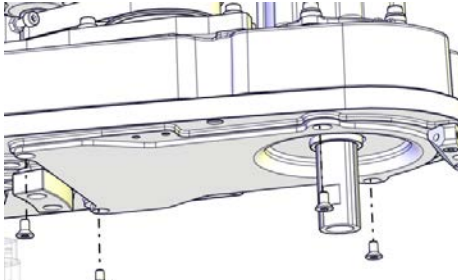
	Action	Note
1	Refit the cover.	<p>Lower cover: 3HAC060106-001</p>  <p>xx1500002225</p>
2	Secure with screws.	 <p>xx1500002785</p> <p>Screw: M4x8 (4 pcs) Tightening torque: 2 Nm</p>

Continues on next page

## 4 Repair

### 4.6.4 Replacing the axis-4 drive unit

*Continued*

Refitting the main cable to the upper arm

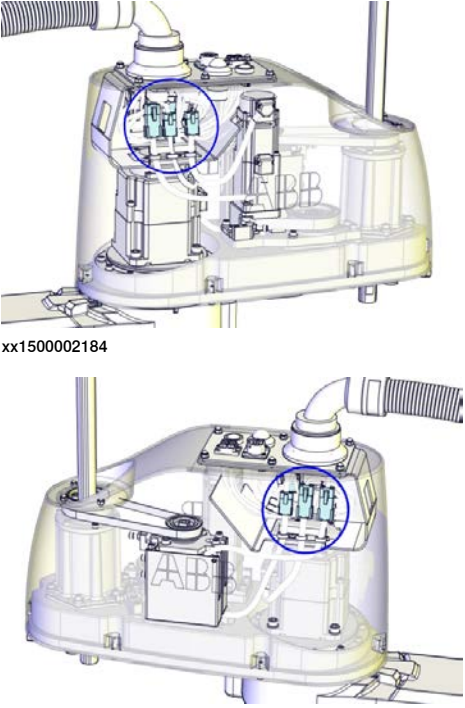
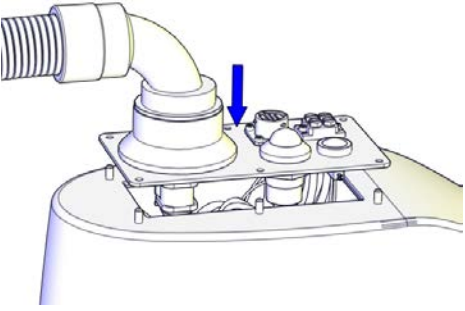
	Action	Note
1	Secure the main cable package with cable ties if needed.	
2	Reconnect the connectors. <ul style="list-style-type: none"><li>• R2.MP2</li><li>• R2.MP3</li><li>• R2.MP4</li><li>• R2.ME2</li><li>• R2.ME3</li><li>• R2.ME4</li></ul>	 <p>Diagram illustrating the reconnection of connectors on the drive unit. The top image (xx1500002184) shows the drive unit with a blue circle highlighting the connector area. The bottom image (xx1500002185) shows the drive unit with a blue circle highlighting the connector area.</p>
3	Push the main cable package into place.	 <p>Diagram illustrating the main cable package being pushed into place. A blue arrow points to the cable package being inserted into the drive unit. (xx1500002207)</p>

*Continues on next page*

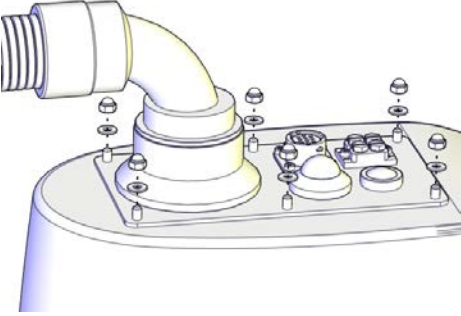
	Action	Note
4	Refit the user interface plate.	 <p data-bbox="973 645 1077 667">xx1500002182</p> <p data-bbox="973 683 1212 712">Dome nut: M4 (6 pcs)</p> <p data-bbox="973 716 1236 745">Tightening torque: 2 Nm</p> <p data-bbox="973 750 1125 779">Washer, 6 pcs</p>

#### Concluding procedure

	Action	Note
1	Recalibrate the robot.	Calibration is detailed in section <a href="#">Calibration on page 349</a> .
2	 <p data-bbox="582 1012 694 1041"><b>DANGER</b></p> <p data-bbox="494 1070 965 1232">Make sure all safety requirements are met when performing the first test run. These are further detailed in the section "First test run may cause injury or damage" in <i>Safety manual for robot - Manipulator and IRC5 or OmniCore controller</i>.</p>	

**This page is intentionally left blank**



## 5 Calibration

### 5.1 Introduction to calibration

#### 5.1.1 Introduction and calibration terminology

##### Calibration information

This chapter includes general information about the recommended calibration methods and also the detailed procedures for updating the revolution counters, checking the calibration position etc.

##### Calibration terminology

Term	Definition
Calibration method	A collective term for several methods that might be available for calibrating the ABB robot. Each method contains calibration routines.
Synchronization position	Known position of the complete robot where the angle of each axis can be checked against visual synchronization marks.
Calibration position	Known position of the complete robot that is used for calibration of the robot.
Standard calibration	A generic term for all calibration methods that aim to move the robot to calibration position.
Fine calibration	A calibration routine that generates a new zero position of the robot.
Reference calibration	<p>A calibration routine that in the first step generates a reference to current zero position of the robot. The same calibration routine can later on be used to recalibrate the robot back to the same position as when the reference was stored.</p> <p>This routine is more flexible compared to fine calibration and is used when tools and process equipment are installed.</p> <p>Requires that a reference is created before being used for recalibrating the robot.</p> <p>Requires that the robot is dressed with the same tools and process equipment during calibration as during creation of the reference values.</p>
Update revolution counter	A calibration routine to make a rough calibration of each manipulator axis.
Synchronization mark	Visual marks on the robot axes. When marks are aligned, the robot is in synchronization position.

## 5 Calibration

### 5.1.2 Calibration methods

### 5.1.2 Calibration methods

#### Overview

This section specifies the different types of calibration and the calibration methods that are supplied by ABB.

#### Types of calibration

Type of calibration	Description	Calibration method
Standard calibration	<p>The calibrated robot is positioned at calibration position.</p> <p>Standard calibration data is found on the SMB (serial measurement board) or EIB in the robot.</p> <p>For robots with RobotWare 5.04 or older, the calibration data is delivered in a file, <code>calib.cfg</code>, supplied with the robot at delivery. The file identifies the correct resolver/motor position corresponding to the robot home position.</p>	Manual calibration
Absolute accuracy calibration (optional)	<p>Based on standard calibration, and besides positioning the robot at synchronization position, the Absolute accuracy calibration also compensates for:</p> <ul style="list-style-type: none"><li>• Mechanical tolerances in the robot structure</li><li>• Deflection due to load</li></ul> <p>Absolute accuracy calibration focuses on positioning accuracy in the Cartesian coordinate system for the robot.</p> <p>Absolute accuracy calibration data is found on the serial measurement board (SMB) or other robot memory.</p> <p>For robots with RobotWare 5.05 or older, the absolute accuracy calibration data is delivered in a file, <code>absacc.cfg</code>, supplied with the robot at delivery. The file replaces the <code>calib.cfg</code> file and identifies motor positions as well as absolute accuracy compensation parameters.</p> <p>A robot calibrated with Absolute accuracy has a sticker next to the identification plate of the robot (IRC5).</p> <p>To regain 100% Absolute accuracy performance, the robot must be recalibrated for absolute accuracy after repair or maintenance that affects the mechanical structure.</p>  <p>xx0400001197</p>	CalibWare

*Continues on next page*

#### Brief description of calibration methods

##### Manual calibration method

With the manual calibration method, the robot's axes are positioned in specific calibration positions using calibration tools. Under this condition, the position of the axis to be calibrated is pre-determined. The axes must be calibrated one at a time.

##### CalibWare - Absolute Accuracy calibration

The CalibWare tool guides through the calibration process and calculates new compensation parameters. This is further detailed in the *Application manual - CalibWare Field*.

If a service operation is done to a robot with the option Absolute Accuracy, a new absolute accuracy calibration is required in order to establish full performance. For most cases after replacements that do not include taking apart the robot structure, standard calibration is sufficient.

---

#### References

Article numbers for the calibration tools are listed in the section [Special tools on page 393](#).

## 5 Calibration

---

### 5.1.3 When to calibrate

### 5.1.3 When to calibrate

---

#### When to calibrate

The system must be calibrated if any of the following situations occur.

#### The resolver values are changed

If resolver values are changed, the robot must be re-calibrated using the calibration methods supplied by ABB. Calibrate the robot carefully with standard calibration, according to information in this manual.

If the robot has *absolute accuracy* calibration, it is also recommended, but not always necessary to calibrate for new absolute accuracy.

The resolver values will change when parts affecting the calibration position are replaced on the robot, for example motors or parts of the transmission.

#### The revolution counter memory is lost

If the revolution counter memory is lost, the counters must be updated. See [Updating revolution counters on page 355](#). This will occur when:

- The battery is discharged
- A resolver error occurs
- The signal between a resolver and measurement board is interrupted
- A robot axis is moved with the control system disconnected

The revolution counters must also be updated after the robot and controller are connected at the first installation.

#### The robot is rebuilt

If the robot is rebuilt, for example, after a crash or when the reachability of a robot is changed, it needs to be re-calibrated for new resolver values.

If the robot has *absolute accuracy* calibration, it needs to be calibrated for new absolute accuracy.

## 5.2 Synchronization marks and axis movement directions

### 5.2.1 Synchronization marks and synchronization position for axes

#### Introduction

This section shows the position of the synchronization marks and the synchronization position for each axis.

#### Synchronization marks, IRB 910SC

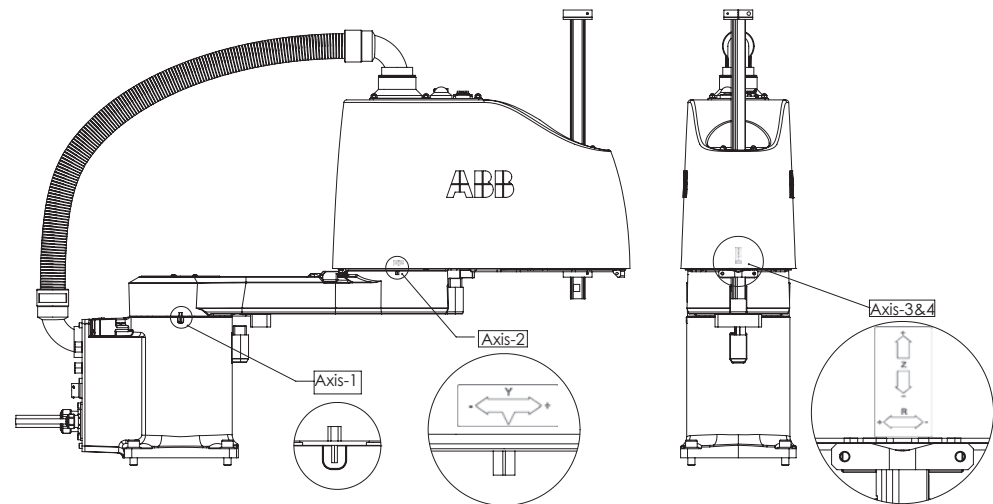

xx1500002634

## 5 Calibration

### 5.2.2 Calibration movement directions for all axes

### 5.2.2 Calibration movement directions for all axes

#### Overview

When calibrating, the axis must consistently be run towards the calibration position in the same direction in order to avoid position errors caused by backlash in gears and so on. Positive directions are shown in the graphic below.

Calibration service routines will handle the calibration movements automatically and these might be different from the positive directions shown below.

#### Manual movement directions

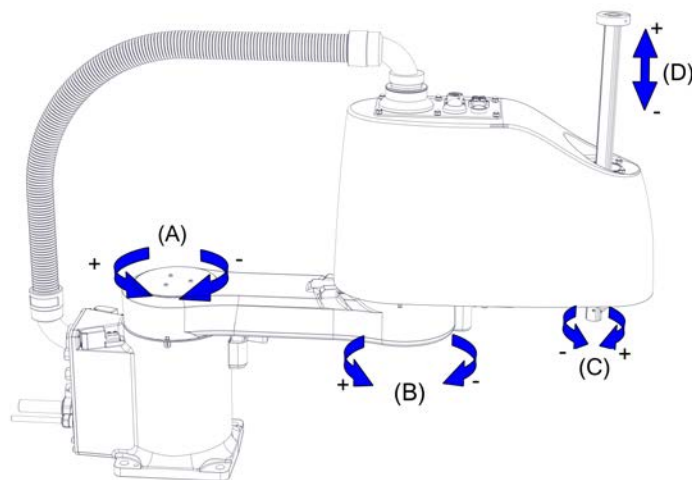

xx150002631

Position	Description	Position	Description
A	Axis 1	B	Axis 2
C	Axis 4	D	Axis 3

## 5.3 Updating revolution counters

### 5.3.1 Updating revolution counters on IRC5 robots

#### Introduction

This section describes how to do a rough calibration of each manipulator axis by updating the revolution counter for each axis, using the FlexPendant.

#### Coupled axes

When updating the revolution counters for a coupled axis, also the axis it is coupled to needs to be at its synchronization position for the update to be correct; i.e. axis 4 needs to be in synchronization position when updating axis 5 and 6.

With reversed coupled joints, the relationship is the opposite, i.e. axis 4 needs to be in synchronization position to update axis 3.

Coupled axes	IRB 140	IRB 1410	IRB 1510	IRB 1520	IRB 1600	IRB 1600ID	IRB 1660ID	IRB 910 SC	IRB 2400	IRB 2600	IRB 2600ID	IRB 4400	IRB 4450S	IRB 4600
Axis 4, 5, 6	x				x				x	x		x	x	x
Axis 5, 6		x	x	x		x	x				x			
Axis 4, 3								x						

#### Step 1 - Manually running the manipulator to the synchronization position

Use this procedure to manually run the manipulator to the synchronization position.

	Action	Note
1	Select axis-by-axis motion mode.	
2	Jog the manipulator to align the synchronization marks.	See <a href="#">Synchronization marks and synchronization position for axes on page 353</a> .
3	When all axes are positioned, update the revolution counter.	<a href="#">Step 2 - Updating the revolution counter with the FlexPendant on page 356</a> .

*Continues on next page*

## 5 Calibration

---

### 5.3.1 Updating revolution counters on IRC5 robots

*Continued*

---

#### Correct calibration position of axes 3 and 4

When jogging the manipulator to synchronization position, it is extremely important to make sure that axes 3 and 4 are positioned correctly. Axis 4 can be calibrated at the wrong turn, resulting in an incorrect axis 3 calibration position and manipulator calibration.

Make sure the notch on the stop block points to the center of fixing calibration block, and the distance between lower surfaces of shaft and fixing calibration block is 33 mm.

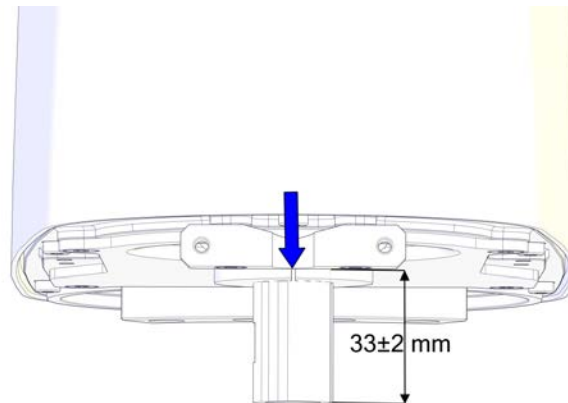

xx1500002907

At delivery the manipulator is in the correct position. Do NOT shift axis 3 or rotate axis 4 at power up before the revolution counters are updated.

If axis 4 is rotated one or more turns from its calibration position before updating the revolution counter, the correct calibration position will be lost due to non-integer gear ratio. This will further affect the calibration position of axis 3.

---

#### Step 2 - Updating the revolution counter with the FlexPendant



#### Note

Revolution counters of axes 3 and 4 must be updated together.

*Continues on next page*



Use this procedure to update the revolution counter with the FlexPendant (IRC5).

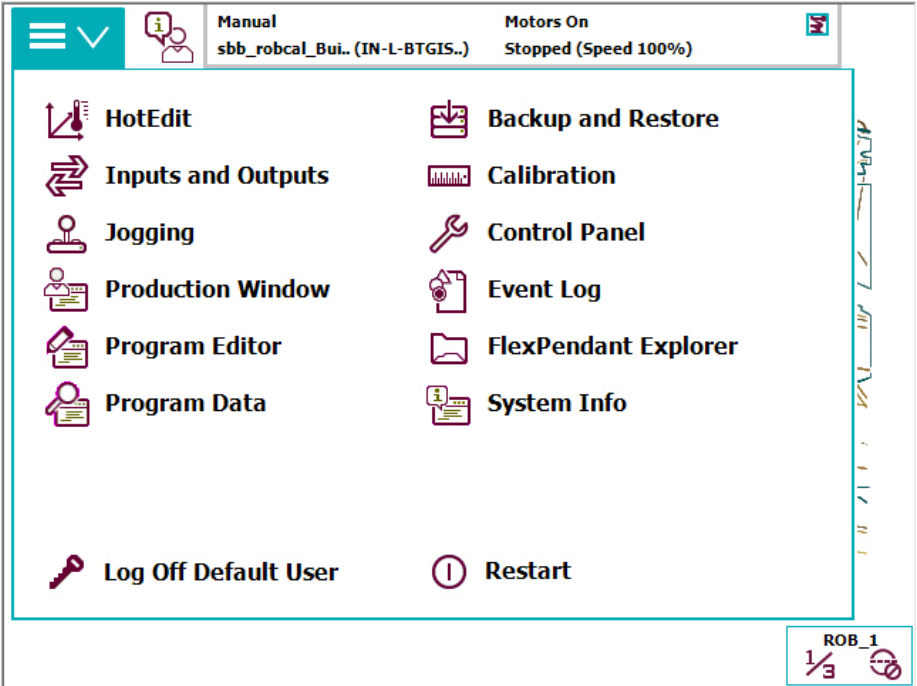
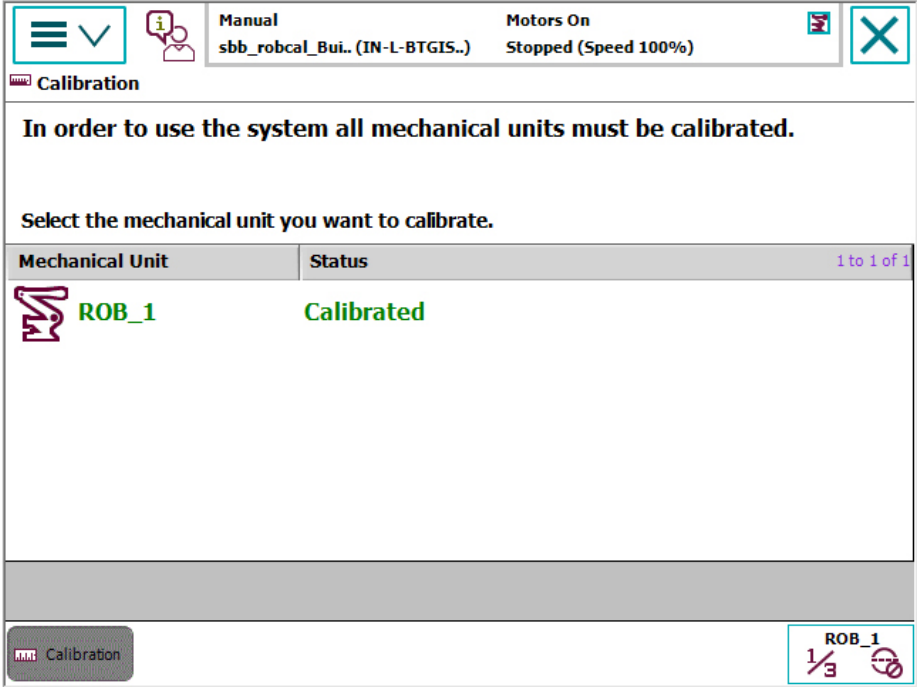

Action	
1	<p>On the ABB menu, tap <b>Calibration</b>.</p>  <p>xx1500000942</p>
2	<p>All mechanical units connected to the system are shown with their calibration status. Tap the mechanical unit in question.</p>  <p>xx1500000943</p>

Continues on next page

## 5 Calibration

### 5.3.1 Updating revolution counters on IRC5 robots

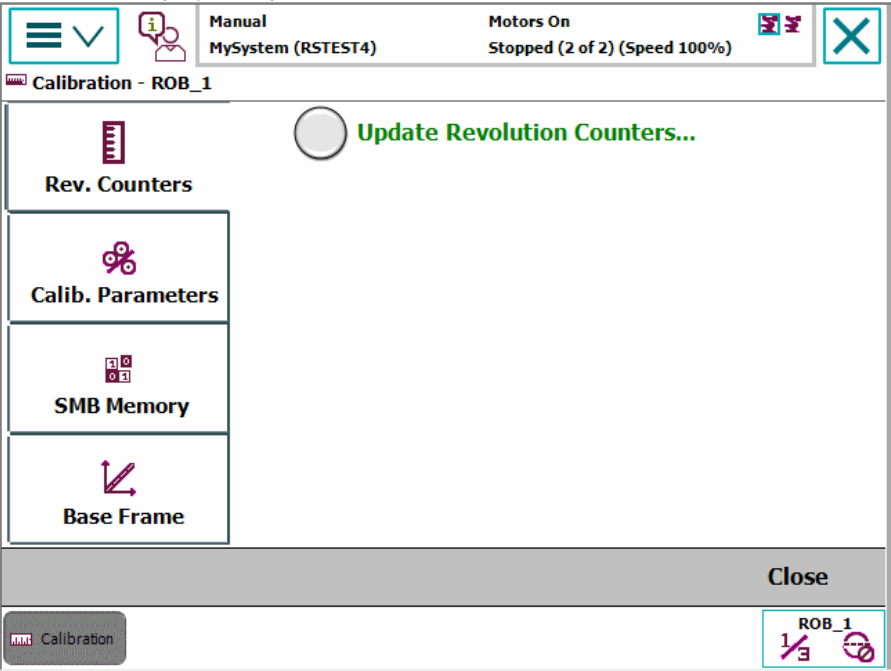
Continued

	Action
3	<p>A screen is displayed, tap <b>Rev. Counters</b>.</p>  <p>en040000771</p>
4	<p>Tap <b>Update Revolution Counters....</b></p> <p>A dialog box is displayed, warning that updating the revolution counters may change programmed robot positions:</p> <ul style="list-style-type: none"><li>• Tap <b>Yes</b> to update the revolution counters.</li><li>• Tap <b>No</b> to cancel updating the revolution counters.</li></ul> <p>Tapping <b>Yes</b> displays the axis selection window.</p>
5	<p>Select the axis to have its revolution counter updated by:</p> <ul style="list-style-type: none"><li>• Ticking in the box to the left</li><li>• Tapping <b>Select all</b> to update all axes.</li></ul> <p>Then tap <b>Update</b>.</p>
6	<p>A dialog box is displayed, warning that the updating operation cannot be undone:</p> <ul style="list-style-type: none"><li>• Tap <b>Update</b> to proceed with updating the revolution counters.</li><li>• Tap <b>Cancel</b> to cancel updating the revolution counters.</li></ul> <p>Tapping <b>Update</b> updates the selected revolution counters and removes the tick from the list of axes.</p>
7	<p> <b>CAUTION</b></p> <p>If a revolution counter is incorrectly updated, it will cause incorrect manipulator positioning, which in turn may cause damage or injury!</p> <p>Check the synchronization position very carefully after each update. See <a href="#">Checking the synchronization position on page 377</a>.</p>

## 5.4 Calibrating the robot

### 5.4.1 Calibration position

---

#### Calibration position

The position of the axis to be calibrated is illustrated in each calibration section respectively.

The table below specifies the exact axis positions in degrees.

Axis	IRB 910SC-3/0.45	IRB 910SC-3/0.55	IRB 910SC-3/0.65
1	-6.9199168°	-6.9199168°	-6.9199168°
2	-7.12701982°	-7.12701982°	-7.12701982°
3	0 mm	0 mm	0 mm
4	0°	0°	0°

## 5 Calibration

---

### 5.4.2 Calibrating axis 1

#### 5.4.2 Calibrating axis 1

---

##### Calibration position of axis 1

The figure shows axis 1 in calibration position, with calibration tools fitted.

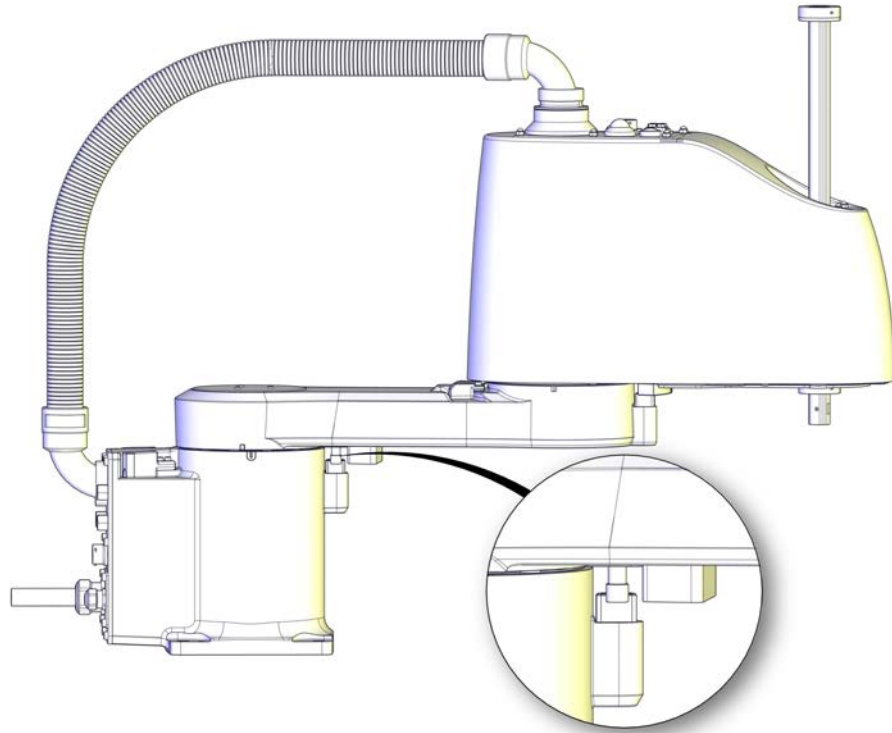

xx1500002512

---

##### Required equipment

Calibration of axis 1 is done by moving the lower arm so that the moving calibration pin and calibration block touches each other gently.

The calibration block is already fitted to the robot.

*Continues on next page*

See figures below for reference, and follow the step-by-step procedure that follows.

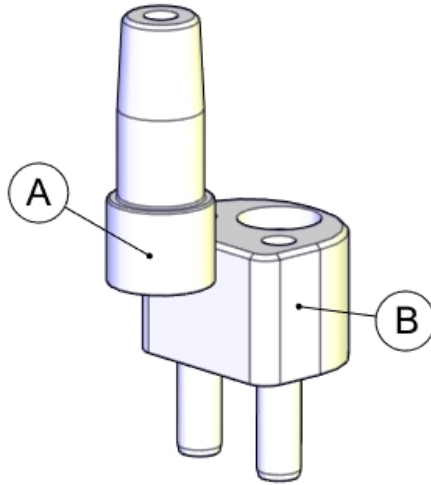

xx1500002516

A	Moving calibration pin
B	Calibration block

**Required consumables**

Equipment	Art. no.	Note
Cleaning agent	-	Isopropanol

**Calibrating axis 1**

**Moving the robot to calibration position**

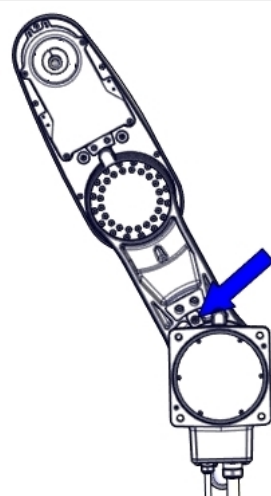



	Action	Note
1	Jog axis 1 to a suitable position where the calibration pin can be fitted in to the press fit bushing.	 <p>xx1500002808</p>

Continues on next page

## 5 Calibration

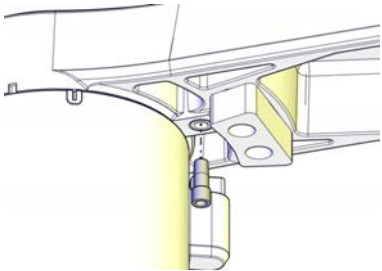
### 5.4.2 Calibrating axis 1

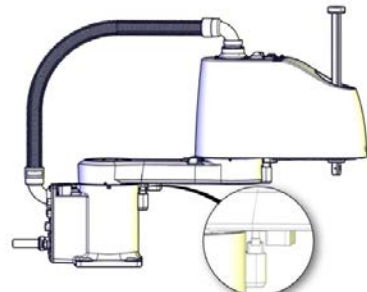
Continued

	Action	Note
2	 <b>DANGER</b> Turn off all: <ul style="list-style-type: none"> <li>• electric power supply</li> <li>• hydraulic pressure supply</li> <li>• air pressure supply</li> </ul> to the robot, before entering the robot working area.	
3	Fit the calibration pin to the press fit bushing.	 xx1500002509
4	Turn on the electric power to the robot.	
5	 <b>DANGER</b> When releasing the holding brakes, the robot axes may move very quickly and sometimes in unexpected ways! Make sure the payload is disassembled or tooling is properly supported; otherwise, fast downward movements of axis 3 may cause severe hits.	
6	Release the brakes and manually rotate axis 1 until the calibration pin touches the calibration block gently. There should be no pressing force between them.	See <a href="#">Manually releasing the brakes on page 62</a> .  xx1500002508
7	 <b>CAUTION</b> Pay attention to robot pose in order to avoid arm collision.	
8	Release the brake release button to activate the brakes.	

Continues on next page

## Performing the fine calibration procedure

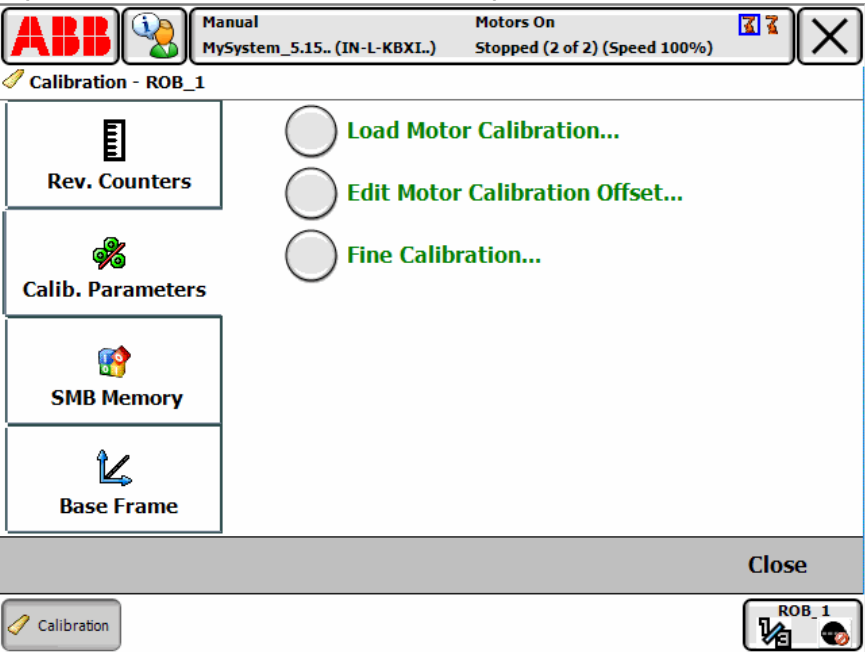
	Action	Note
1	 <b>WARNING</b> Do not fine calibrate the robot without special equipment used for axis calibration! It would cause an unsatisfied accuracy in the robot movement.	
2	Choose fine calibration from Calib menu. On the <b>ABB</b> menu, tap <b>Calibration</b> . All mechanical units connected to the system are shown along with their calibration status.	
3	Tap to select the mechanical unit and then tap <b>Calib. Parameters</b> . 	
4	<b>Tap Fine Calibration....</b> A dialog box is displayed, urging you to use external equipment to perform the actual calibration. Make sure all necessary calibration equipment is fitted for the axis to be calibrated. A dialog box is displayed, warning that updating the revolution counters may change programmed robot positions: <ul style="list-style-type: none"> <li>• Tap <b>Yes</b> to proceed.</li> <li>• Tap <b>No</b> to cancel.</li> </ul>	
5	Select the check-box for the current axis/axes to be calibrated.	

Continues on next page

## 5 Calibration

### 5.4.2 Calibrating axis 1

Continued

	Action	Note
6	<p>Tap <b>Calibrate</b>.</p> <p>A dialog box is displayed, warning that calibration of the selected axes will be changed, which cannot be undone:</p> <ul style="list-style-type: none"> <li>• Tap <b>Calibrate</b> to proceed.</li> <li>• Tap <b>Cancel</b> to cancel.</li> </ul> <p>Tapping <b>Calibrate</b> results in briefly displaying a dialog box, announcing that the calibration process has started.</p> <p>The axis is calibrated and the system returns to the list of available mechanical units.</p>	

#### Checking and finalizing the calibration

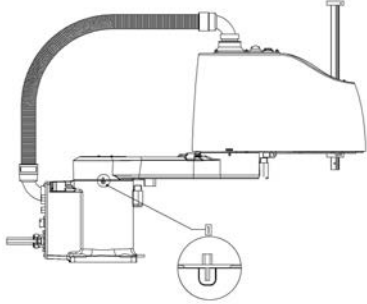
	Action	Note
1	 <p><b>DANGER</b></p> <p>Always remember to remove the calibration tools from the robot before jogging axes to zero position during calibration.</p>	
2	<p>Release the brakes and manually rotate the axis to apart the calibration pins from each other. This is done to avoid damage on the pins if incorrect operation should occur during next step of jogging.</p>	
3	<p>Jog axis 1 to zero degree using the FlexPendant.</p>	
4	<p>Check that the synchronization marks on axis 1 are aligned with each other.</p> <p>Are they aligned within the tolerances?</p> <ul style="list-style-type: none"> <li>• If yes, the calibration is verified OK.</li> <li>• If no, redo the fine calibration procedure.</li> </ul>	 <p>xx1500002514</p>

#### After calibration

	Action	Note
1	<p>Write down the new system parameters on a new label and stick on top of the calibration label on the robot.</p>	



### 5.4.3 Calibrating axis 2

#### Calibration position of axis 2

The figure shows axis 2 in calibration position.

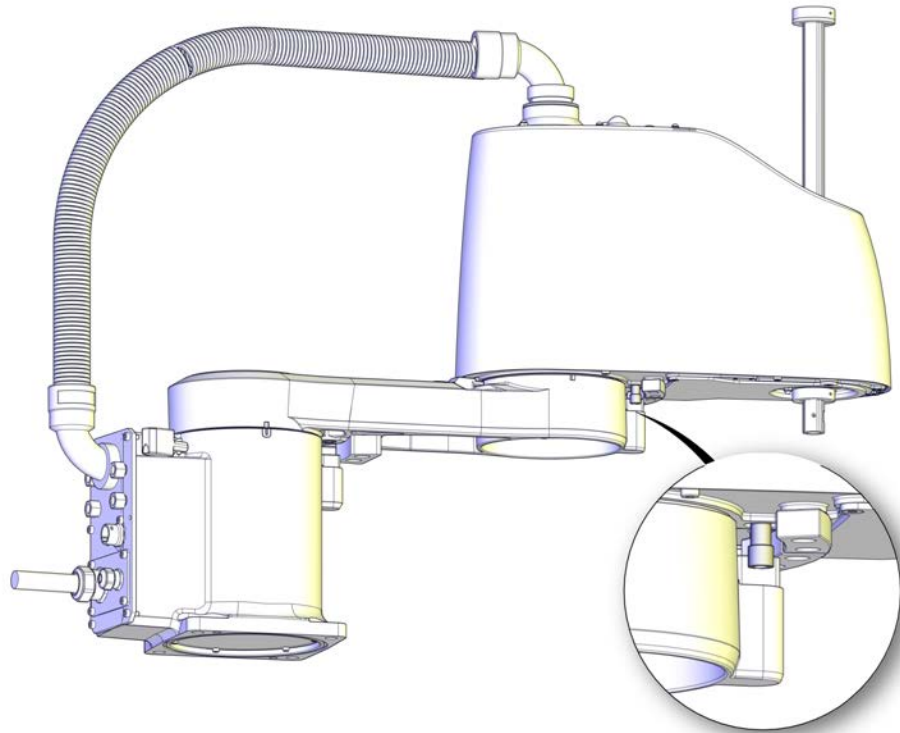

xx1500002513

#### Required equipment

Calibration of axis 2 is done by moving the lower arm so that the moving calibration pin and calibration block touches each other gently.

The calibration block is already fitted to the robot.

*Continues on next page*

## 5 Calibration

### 5.4.3 Calibrating axis 2

*Continued*

See figures below for reference, and follow the step-by-step procedure that follows.

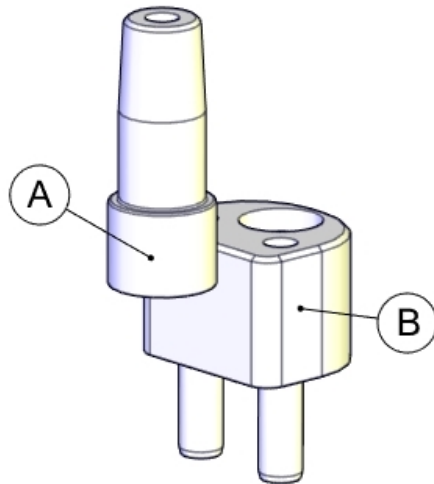

xx1500002516

A	Moving calibration pin
B	Calibration block

#### Required consumables



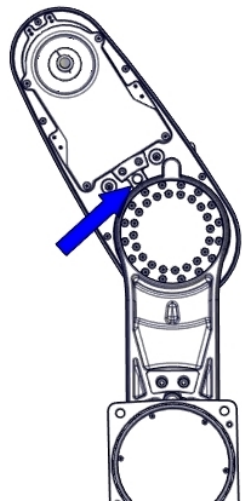

Equipment	Art. no.	Note
Cleaning agent	-	Isopropanol

#### Calibrating axis 2

##### Moving the robot to calibration position

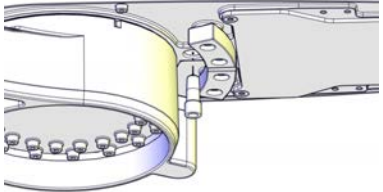
	Action	Note
1	Jog axis 2 to a suitable position where the calibration pin can be fitted to the press fit bushing.	 <p>xx1500002809</p>

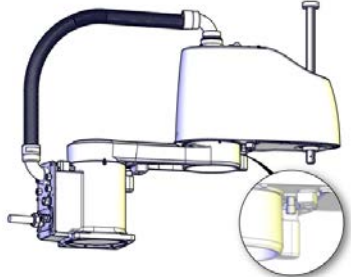
*Continues on next page*

	Action	Note
2	 <b>DANGER</b> Turn off all: <ul style="list-style-type: none"> <li>• electric power supply</li> <li>• hydraulic pressure supply</li> <li>• air pressure supply</li> </ul> to the robot, before entering the robot working area.	
3	Fit the calibration pin to the press fit bushing.	 xx1500002511
4	Turn on the electric power to the robot.	
5	 <b>DANGER</b> When releasing the holding brakes, the robot axes may move very quickly and sometimes in unexpected ways! Make sure the payload is disassembled or tooling is properly supported; otherwise, fast downward movements of axis 3 may cause severe hits.	
6	Release the brakes and manually rotate axis 2 until the calibration pin touches the calibration block gently. There should be no pressing force between them.	See <a href="#">Manually releasing the brakes on page 62</a> .  xx1500002510
7	 <b>CAUTION</b> Pay attention to robot pose in order to avoid arm collision.	
8	Release the brake release button to activate the brakes.	

*Continues on next page*

## 5 Calibration

### 5.4.3 Calibrating axis 2

*Continued*

Performing the fine calibration procedure

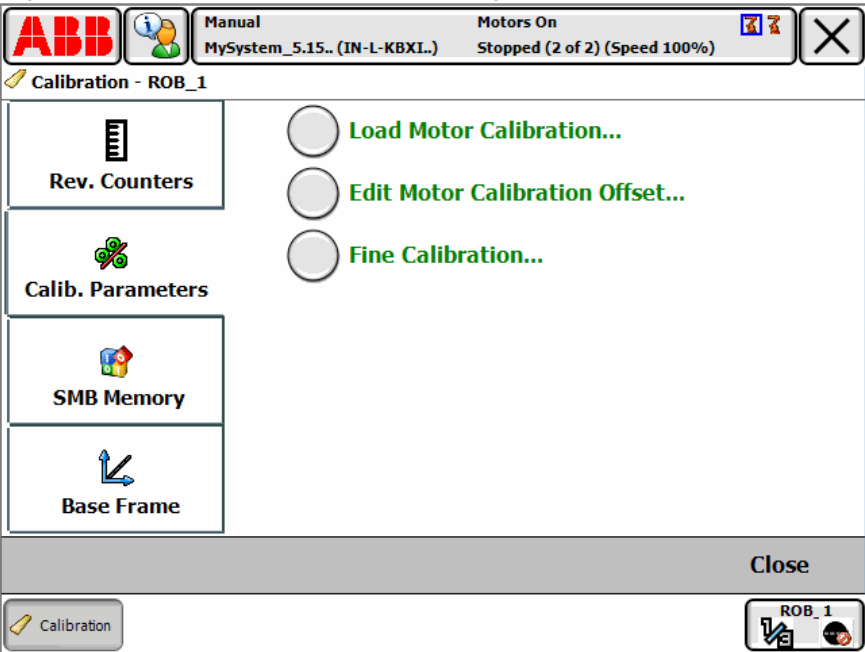
	Action	Note
1	 <b>WARNING</b> Do not fine calibrate the robot without special equipment used for axis calibration! It would cause an unsatisfied accuracy in the robot movement.	
2	Choose fine calibration from Calib menu. On the <b>ABB</b> menu, tap <b>Calibration</b> . All mechanical units connected to the system are shown along with their calibration status.	
3	Tap to select the mechanical unit and then tap <b>Calib. Parameters</b> . 	
4	<b>Tap Fine Calibration....</b> A dialog box is displayed, urging you to use external equipment to perform the actual calibration. Make sure all necessary calibration equipment is fitted for the axis to be calibrated. A dialog box is displayed, warning that updating the revolution counters may change programmed robot positions: <ul style="list-style-type: none"> <li>• Tap <b>Yes</b> to proceed.</li> <li>• Tap <b>No</b> to cancel.</li> </ul>	
5	Select the check-box for the current axis/axes to be calibrated.	

*Continues on next page*

	Action	Note
6	<p><b>Tap Calibrate.</b></p> <p>A dialog box is displayed, warning that calibration of the selected axes will be changed, which cannot be undone:</p> <ul style="list-style-type: none"> <li>• Tap <b>Calibrate</b> to proceed.</li> <li>• Tap <b>Cancel</b> to cancel.</li> </ul> <p>Tapping <b>Calibrate</b> results in briefly displaying a dialog box, announcing that the calibration process has started.</p> <p>The axis is calibrated and the system returns to the list of available mechanical units.</p>	

#### Checking and finalizing the calibration

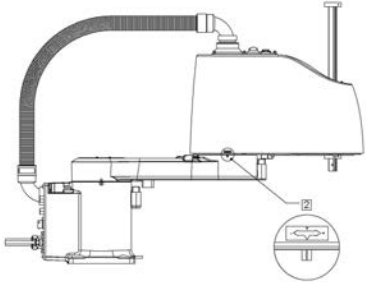
	Action	Note
1	 <p><b>DANGER</b></p> <p>Always remember to remove the calibration tools from the robot before jogging axes to zero position during calibration.</p>	
2	<p>Release the brakes and manually rotate the axis to apart the calibration pins from each other. This is done to avoid damage on the pins if incorrect operation should occur during next step of jogging.</p>	
3	<p>Jog axis 2 to zero degree using the FlexPendant.</p>	
4	<p>Check that the synchronization marks on axis 2 are aligned with each other.</p> <p>Are they aligned within the tolerances?</p> <ul style="list-style-type: none"> <li>• If yes, the calibration is verified OK.</li> <li>• If no, redo the fine calibration procedure.</li> </ul>	 <p>xx1500002515</p>

#### After calibration

	Action	Note
1	<p>Write down the new system parameters on a new label and stick on top of the calibration label on the robot.</p>	

## 5 Calibration

---

### 5.4.4 Calibrating axis 3 and axis 4

#### 5.4.4 Calibrating axis 3 and axis 4

---

##### Calibration position of axis 3 and axis 4

The figure shows axis 3 and axis 4 in calibration position. The axes 3 and 4 are calibrated together.

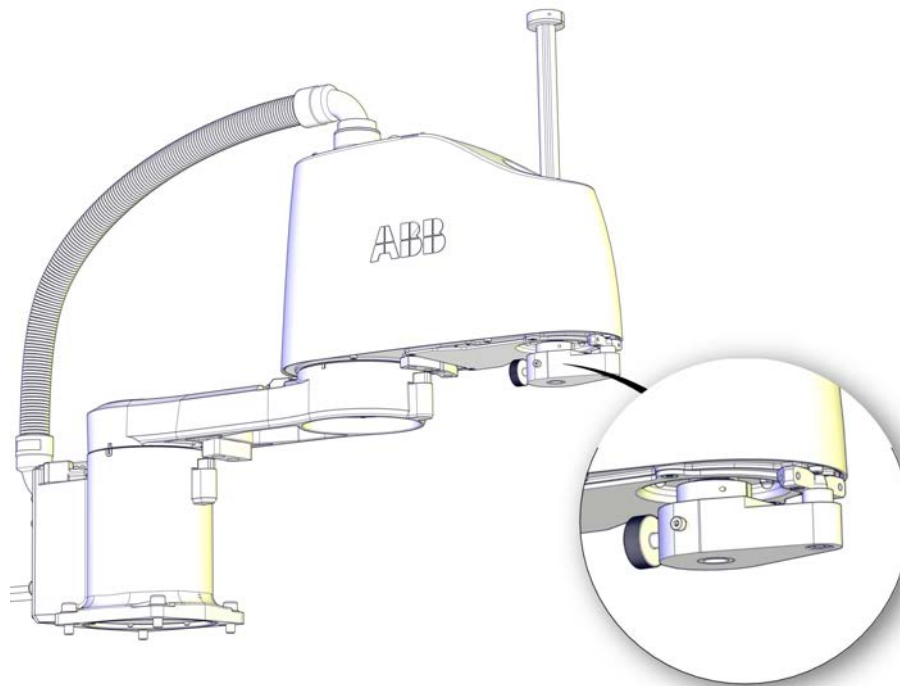

xx1500002499

---

##### Required equipment

Axes 3 and 4 are calibrated together. The calibration is done by moving the ball screw spline unit so that the calibration pin on the moving calibration block and the fixing calibration block touch each other gently.

The fixing calibration block is already fitted to the robot.

*Continues on next page*

See figures below for reference, and follow the step-by-step procedure that follows the figures.

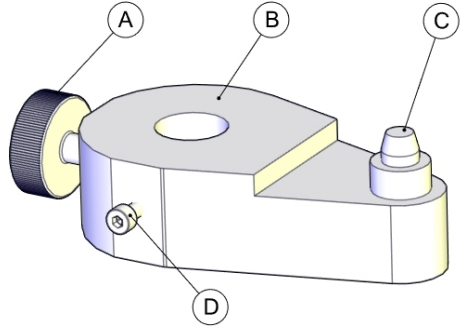
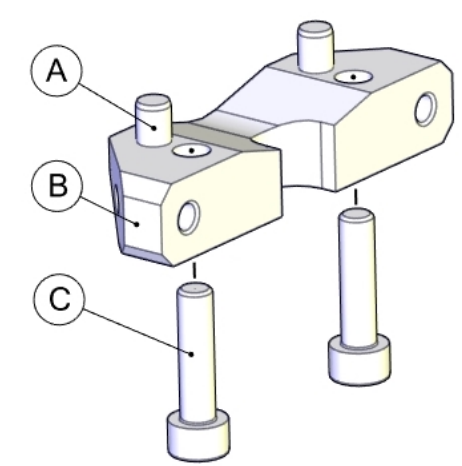
Moving calibration block (including calibration pin, knob and adjusting screw)	Fixing calibration block (including parallel pins and attachment screws)
 <p>xx1500002500</p> <ul style="list-style-type: none"> <li>A Knob</li> <li>B Moving calibration block</li> <li>C Calibration pin</li> <li>D Screw</li> </ul>	 <p>xx1500002501</p> <ul style="list-style-type: none"> <li>A Parallel pin</li> <li>B Fixing block</li> <li>C Screw</li> </ul>

#### Required consumables

Equipment	Art. no.	Note
Cleaning agent	-	Isopropanol

#### Calibrating axis 3 and axis 4

##### Moving the robot to calibration position

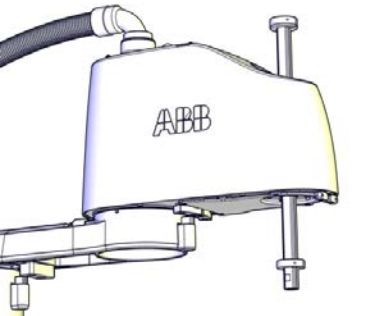
	Action	Note
1	Jog axis 3 and axis 4 to find a suitable position where axis-3/4 calibration tools can be fitted.	 <p>xx1500002502</p>

*Continues on next page*

## 5 Calibration

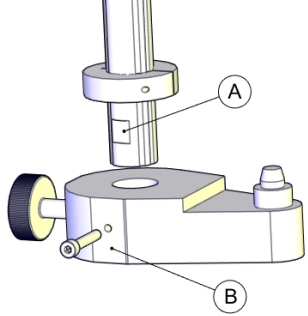
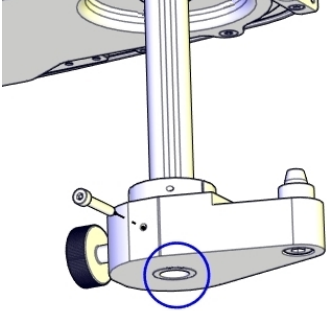
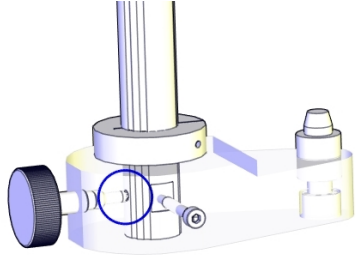

### 5.4.4 Calibrating axis 3 and axis 4

Continued

	Action	Note
2	<p> <b>DANGER</b></p> <p>Turn off all:</p> <ul style="list-style-type: none"> <li>• electric power supply</li> <li>• hydraulic pressure supply</li> <li>• air pressure supply</li> </ul> <p>to the robot, before entering the robot working area.</p>	
3	<p>Fit the moving calibration block with its flat part aligned with the shaft flat mark.</p>	 <p>xx1500002503</p> <p><b>A</b> Shaft flat mark <b>B</b> Block flat part</p>
4	<p>When the lower surfaces of the shaft and block are at the same level, tighten the screw slowly to a degree just enough to ensure the block not drop.</p>	 <p>xx1500002504</p>
5	<p>Turn the knob gently until its sphere head is properly inserted into the conical hole.</p>	 <p>xx1500002505</p>
6	<p>Tighten the screw to lock the block on the shaft.</p>	
7	<p>Turn on the electric power to the robot.</p>	

Continues on next page



	Action	Note
8	 <p><b>DANGER</b></p> <p>When releasing the holding brakes, the robot axes may move very quickly and sometimes in unexpected ways!</p> <p>Make sure the payload is disassembled or tooling is properly supported; otherwise, fast downward movements of axis 3 may cause severe hits.</p>	
9	<p>Release the brakes and manually move the ball screw spline up and down until:</p> <ul style="list-style-type: none"> <li>the calibration pin on the moving calibration block locates in the groove of the fixing calibration block and;</li> <li>the contact surfaces of the calibration pin and fixing calibration block touches each other gently; there should be no pressing force between the surfaces.</li> </ul> <p>When doing this, pay attention to robot pose in order to avoid arm collision.</p> <p>When the axes are in position, release the brake release button to activate the brakes again.</p>	<p>How to release the brakes is detailed in <a href="#">Manually releasing the brakes on page 62</a>.</p>  <p>xx1500002506</p>

Performing the fine calibration procedure

	Action	Note
1	 <p><b>WARNING</b></p> <p>Do not fine calibrate the robot without special equipment used for axis calibration! It would cause an unsatisfied accuracy in the robot movement.</p>	
2	<p>Choose fine calibration from Calib menu.</p> <p>On the <b>ABB</b> menu, tap <b>Calibration</b>.</p> <p>All mechanical units connected to the system are shown along with their calibration status.</p>	

Continues on next page

## 5 Calibration

### 5.4.4 Calibrating axis 3 and axis 4

Continued

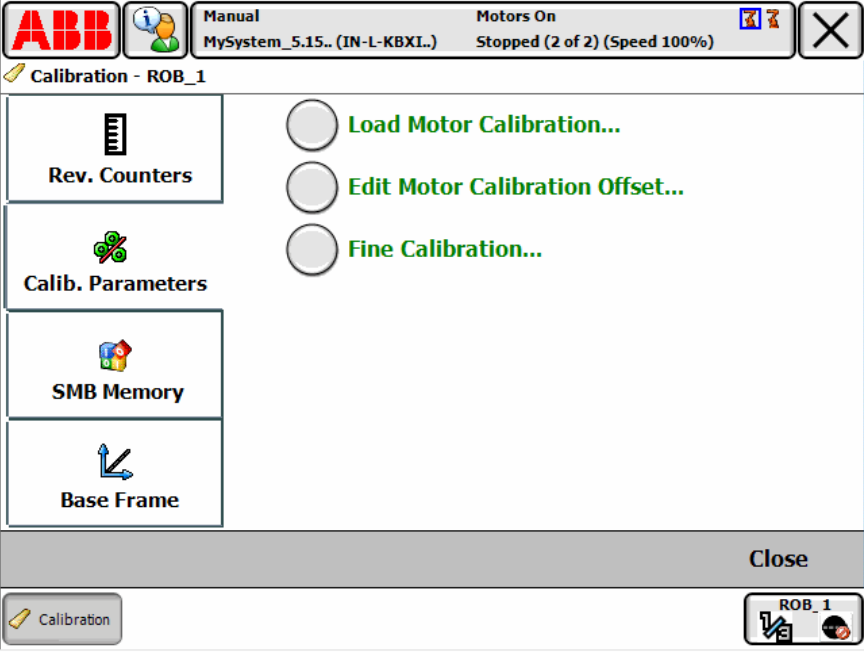
	Action	Note
3	<p>Tap to select the mechanical unit and then tap <b>Calib. Parameters</b>.</p>  <p>en0400001127</p>	
4	<p>Tap <b>Fine Calibration....</b></p> <p>A dialog box is displayed, urging you to use external equipment to perform the actual calibration. Make sure all necessary calibration equipment is fitted for the axis to be calibrated.</p> <p>A dialog box is displayed, warning that updating the revolution counters may change programmed robot positions:</p> <ul style="list-style-type: none"> <li>• Tap <b>Yes</b> to proceed.</li> <li>• Tap <b>No</b> to cancel.</li> </ul>	
5	<p>Select the check-box for the current axis/axes to be calibrated.</p>	
6	<p>Tap <b>Calibrate</b>.</p> <p>A dialog box is displayed, warning that calibration of the selected axes will be changed, which cannot be undone:</p> <ul style="list-style-type: none"> <li>• Tap <b>Calibrate</b> to proceed.</li> <li>• Tap <b>Cancel</b> to cancel.</li> </ul> <p>Tapping <b>Calibrate</b> results in briefly displaying a dialog box, announcing that the calibration process has started.</p> <p>The axis is calibrated and the system returns to the list of available mechanical units.</p>	

Continues on next page

Checking and finalizing the calibration

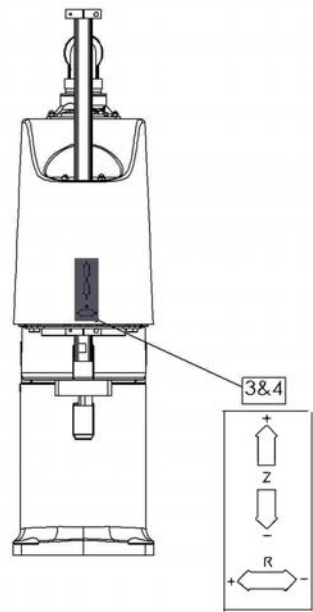
	Action	Note
1	 <b>DANGER</b> Always remember to remove the calibration tools from the robot before jogging axes to zero position during calibration.	
2	Release the brakes and manually rotate the axis to apart the calibration pins from each other. This is done to avoid damage on the pins if incorrect operation should occur during next step of jogging.	
3	Jog axes 3 and 4 to zero degree using the Flex-Pendant.	
4	Check that the synchronization marks on axes 3 and 4 are aligned with each other. Are they aligned within the tolerances? <ul style="list-style-type: none"> <li>• If yes, the calibration is verified OK.</li> <li>• If no, redo the fine calibration procedure.</li> </ul>	 <p>xx1500002507</p>

After calibration

	Action	Note
1	Write down the new system parameters on a new label and stick on top of the calibration label on the robot.	

## 5 Calibration

---

### 5.5 Verifying the calibration

### 5.5 Verifying the calibration

---

#### Introduction

Always verify the results after calibrating *any* robot axis to verify that all calibration positions are correct.

---

#### Verifying the calibration

Use this procedure to verify the calibration result.

	Action	Note
1	Run the calibration home position program twice. Do not change the position of the robot axes after running the program!	See <a href="#">Checking the synchronization position on page 377</a> .
2	Adjust the <i>synchronization marks</i> when the calibration is done, if necessary.	This is detailed in section <a href="#">Synchronization marks and synchronization position for axes on page 353</a> .
3	Write down the values on a new label and stick it on top of the calibration label. The label is located on the base.	
4	Remove any calibration equipment from the robot.	

## 5.6 Checking the synchronization position

### Introduction

Check the synchronization position of the robot before beginning any programming of the robot system. This may be done:

- Using a `MoveAbsJ` instruction with argument zero on all axes.
- Using the **Jogging** window on the FlexPendant.

### Using a `MoveAbsJ` instruction

Use this procedure to create a program that runs all the robot axes to their synchronization position.

	Action	Note
1	On ABB menu tap <b>Program editor</b> .	
2	Create a new program.	
3	Use <b>MoveAbsJ</b> in the <b>Motion&amp;Proc</b> menu.	
4	Create the following program: <pre>MoveAbsJ [[0,0,0,0,0,0],           [9E9,9E9,9E9,9E9,9E9,9E9]] \NoEOffs, v1000, fine, tool0</pre>	
5	Run the program in manual mode.	
6	Check that the synchronization marks for the axes align correctly. If they do not, update the revolution counters.	See <a href="#">Synchronization marks and synchronization position for axes on page 353</a> and <a href="#">Updating revolution counters on page 355</a> .

### Using the jogging window

Use this procedure to jog the robot to the synchronization position of all axes.

	Action	Note
1	On the <b>ABB</b> menu, tap <b>Jogging</b> .	
2	Tap <b>Motion mode</b> to select group of axes to jog.	
3	Tap to select the axis to jog, axis 1, 2, or 3.	
4	Manually run the robots axes to a position where the axis position value read on the FlexPendant, is equal to zero.	
5	Check that the synchronization marks for the axes align correctly. If they do not, update the revolution counters.	See <a href="#">Synchronization marks and synchronization position for axes on page 353</a> and <a href="#">Updating revolution counters on page 355</a> .

**This page is intentionally left blank**

# 6 Decommissioning

## 6.1 Introduction to decommissioning

### Introduction

This section contains information to consider when taking a product, robot or controller, out of operation.

It deals with how to handle potentially dangerous components and potentially hazardous materials.



#### Note

The decommissioning process shall be preceded by a risk assessment.

### Disposal of materials used in the robot

All used grease/oils and dead batteries **must** be disposed of in accordance with the current legislation of the country in which the robot and the control unit are installed.

If the robot or the control unit is partially or completely disposed of, the various parts **must** be grouped together according to their nature (which is all iron together and all plastic together), and disposed of accordingly. These parts **must** also be disposed of in accordance with the current legislation of the country in which the robot and control unit are installed.

See also [Environmental information on page 380](#).

### Transportation

Prepare the robot or parts before transport, this to avoid hazards.

## 6 Decommissioning

### 6.2 Environmental information

## 6.2 Environmental information

### Introduction

ABB robots contain components in different materials. During decommissioning, all materials should be dismantled, recycled, or reused responsibly, according to the relevant laws and industrial standards. Robots or parts that can be reused or upcycled helps to reduce the usage of natural resources.

### Symbol

The following symbol indicates that the product must not be disposed of as common garbage. Handle each product according to local regulations for the respective content (see table below).

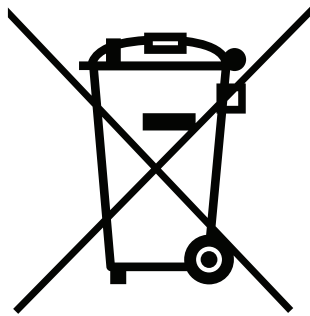

xx1800000058

### Materials used in the product

The table specifies some of the materials in the product and their respective use throughout the product.

Dispose components properly according to local regulations to prevent health or environmental hazards.

Material	Example application
Aluminium	Base, upper arm, lower arm, axis-3 housing, etc
Batteries, Lithium	Battery pack
Neodymium	Drive units
Oil, grease	Drive units, ball screw spline unit
Plastic/rubber	Upper arm cover, mechanical stop rubbers
Steel	Drive units, ball screw spline unit, etc

### Oil and grease

Where possible, arrange for oil and grease to be recycled. Dispose of via an authorized person/contractor in accordance with local regulations. Do not dispose of oil and grease near lakes, ponds, ditches, down drains, or onto soil. Incineration must be carried out under controlled conditions in accordance with local regulations.

*Continues on next page*



Also note that:

- Spills can form a film on water surfaces causing damage to organisms. Oxygen transfer could also be impaired.
- Spillage can penetrate the soil causing ground water contamination.

**This page is intentionally left blank**

# 7 Reference information

## 7.1 Introduction

---

### General

This chapter includes general information, complementing the more specific information in the different procedures in the manual.

## 7 Reference information

### 7.2 Applicable standards

### 7.2 Applicable standards



#### Note

The listed standards are valid at the time of the release of this document. Phased out or replaced standards are removed from the list when needed.

#### General

The product is designed in accordance with ISO 10218-1:2011, Robots for industrial environments - Safety requirements -Part 1 Robots, and applicable parts in the normative references, as referred to from ISO 10218-1:2011. In case of deviations from ISO 10218-1:2011, these are listed in the declaration of incorporation which is part of the product delivery.

#### Normative standards as referred to from ISO 10218-1

Standard	Description
ISO 9283:1998	Manipulating industrial robots - Performance criteria and related test methods
ISO 10218-2	Robots and robotic devices - Safety requirements for industrial robots - Part 2: Robot systems and integration
ISO 12100	Safety of machinery - General principles for design - Risk assessment and risk reduction
ISO 13849-1:2006	Safety of machinery - Safety related parts of control systems - Part 1: General principles for design
ISO 13850	Safety of machinery - Emergency stop - Principles for design
IEC 60204-1	Safety of machinery - Electrical equipment of machines - Part 1: General requirements

#### Deviation for delay circuit

Some variants of IRB 910SC has an inherent delay circuit to enhance the lifetime of speed reducers. This only applies to variants IRB 910SC-3/0.45, IRB 910SC-3/0.55, and IRB 910SC-3/0.65.

This circuit allows an extended time period for soft stop by enabling a delay of about 0.5 s before motor brakes are engaged, e.g. when the three-position enabling device is released or compressed, or the emergency stop is pressed. During this period, the robot axes 1 and 2 will continue their movement until they are stopped by the motor or eventually by brakes. Make sure the robot safeguarded area is free from obstacles, even during manual operations. Note that this delay does not apply to axes 3 and 4.

For more details regarding stopping time and distance metric, see *Product specification - Robot stopping distances according to ISO 10218-1*.

#### Region specific standards and regulations

Standard	Description
ANSI/RIA R15.06	Safety requirements for industrial robots and robot systems

*Continues on next page*

Standard	Description
ANSI/UL 1740	Safety standard for robots and robotic equipment
CAN/CSA Z 434-03	Industrial robots and robot Systems - General safety requirements

#### Other standards used in design

Standard	Description
ISO 9787:2013	Robots and robotic devices -- Coordinate systems and motion nomenclatures
IEC 61000-6-2	Electromagnetic compatibility (EMC) – Part 6-2: Generic standards – Immunity standard for industrial environments
IEC 61000-6-4	Electromagnetic compatibility (EMC) – Part 6-4: Generic standards – Emission standard for industrial environments
ISO 13732-1:2006	Ergonomics of the thermal environment - Part 1
IEC 60974-1:2012 <sup>i</sup>	Arc welding equipment - Part 1: Welding power sources
IEC 60974-10:2014 <sup>i</sup>	Arc welding equipment - Part 10: EMC requirements
ISO 14644-1:2015 <sup>ii</sup>	Classification of air cleanliness
IEC 60529:1989 + A2:2013	Degrees of protection provided by enclosures (IP code)

<sup>i</sup> Only valid for arc welding robots. Replaces IEC 61000-6-4 for arc welding robots.

<sup>ii</sup> Only robots with protection Clean Room.

## 7 Reference information

---

### 7.3 Unit conversion

### 7.3 Unit conversion

---

#### Converter table

Use the following table to convert units used in this manual.

Quantity	Units		
Length	1 m	3.28 ft.	39.37 in
Weight	1 kg	2.21 lb.	
Weight	1 g	0.035 ounces	
Pressure	1 bar	100 kPa	14.5 psi
Force	1 N	0.225 lbf	
Moment	1 Nm	0.738 lbf-ft	
Volume	1 L	0.264 US gal	

## 7.4 Specification of screws

### Screws, nuts and washers not handled as spare parts

The screws, nuts and washers listed have no special treatment and can be bought locally if lost or damaged.

Screw/Nut/Washer	Dimension, class and treatment
Hex socket head cap screw	M5x16 12.9 Steel Black Oxide
Hex socket head cap screw	M5x25 12.9 Steel Black Oxide
Hex socket head cap screw	M6x30 12.9 Steel Black Oxide
Hex socket head cap screw	M3x8 12.9 Steel Black Oxide
Hex socket head cap screw	M3x20 12.9 Steel Black Oxide
Hex socket head cap screw	M4x16 12.9 Steel Black Oxide
Hex socket head cap screw	M4x25 12.9 Steel Black Oxide
Hex socket head cap screw	M4x20 12.9 Steel Black Oxide
Hex socket head cap screw	M5x12 12.9 Steel Black Oxide
Hex socket head cap screw	M3x12 12.9 Steel Black Oxide
Hex socket head cap screw	M4x12 12.9 Steel Black Oxide
Hex socket head cap screw	M2.5x6 12.9 Steel Black Oxide
Hex socket head cap screw	M4x30 12.9 Steel Black Oxide
Hex socket head cap screw	M4x10 12.9 Steel Black Oxide
Hex socket head cap screw	M6x16 8.8 Steel Zinc electroplated and chromated, bluish
Torx pan head screw	M3x4 8.8 Steel Zinc electroplated and chromated, bluish
Torx pan head screw	M3x6 8.8 Steel Zinc electroplated and chromated, bluish
Hex socket counters. flat head screw	M4x8 8.8 Steel Zinc electroplated and chromated, bluish
Hex socket pan head thread rolling screw	M3x6 8.8 Stainless steel Zinc electroplated and chromated, bluish
Hexagon domed cap nut	M4 DIN1587 Stainless steel A2
Hexagon nut	M4 8 Steel Zinc electroplated and chromated, bluish
Plain washer	4.3x9x0.8 200HV Steel Zinc electroplated and chromated, bluish
Plain washer	6.4x12x1.6 200HV Steel Zinc electroplated and chromated, bluish
Plain washer	6.4x17x3 200HV Steel Zinc electroplated and chromated, bluish
Conical spring washer	3.2x7x0.6 420-510HV Spring steel acc.to DIN267 Teil26 Zinc plated mechanically and chromated, bluish
Conical spring washer	4.3x9x1 420-510HV Spring steel acc.to DIN267 Teil26 Zinc plated mechanically and chromated, bluish
Conical spring washer	5.3x11x1.2 420-510HV Spring steel acc.to DIN267 Teil26 Zinc plated mechanically and chromated, bluish

## 7 Reference information

---

### 7.5 Screw joints

### 7.5 Screw joints

---

#### General

This section describes how to tighten the various types of screw joints on ABB robots.

The instructions and torque values are valid for screw joints comprised of metallic materials and do *not* apply to soft or brittle materials.

---

#### UNBRAKO screws

UNBRAKO is a special type of screw recommended by ABB for certain screw joints. It features special surface treatment (Gleitmo as described below) and is extremely resistant to fatigue.

Whenever used, this is specified in the instructions, and in such cases, *no other type of replacement screw* is allowed. Using other types of screws will void any warranty and may potentially cause serious damage or injury.

---

#### Gleitmo treated screws

Gleitmo is a special surface treatment to reduce the friction when tightening the screw joint. It is recommended by ABB for M6-M20 screw joints. Screws treated with Gleitmo may be reused 3-4 times before the coating disappears. After this the screw must be discarded and replaced with a new one.

When handling screws treated with Gleitmo, protective gloves of nitrile rubber type should be used.

Generally, screws are lubricated with *Gleitmo 603* mixed with *Geomet 500* or *Geomet 702* in proportion 1:3. *Geomet* thickness varies according to screw dimensions, refer to the following.

Dimension	Lubricant	Geomet thickness
M6-M20 (any length except M20x60)	<i>Gleitmo 603 + Geomet 500</i>	3-5 µm
M6-M20 (any length except M20x60)	<i>Gleitmo 603 + Geomet 720</i>	3-5 µm
M20x60	<i>Gleitmo 603 + Geomet 500</i>	8-12 µm
M20x60	<i>Gleitmo 603 + Geomet 720</i>	6-10 µm

---

#### Screws lubricated in other ways

Screws lubricated with Molykote 1000 or Molykote P1900 should *only* be used when specified in the repair, maintenance or installation procedure descriptions.

In such cases, proceed as follows:

- 1 Apply lubricant to the screw thread.
- 2 Apply lubricant between the plain washer and screw head.
- 3 Screw dimensions of M8 or larger must be tightened with a torque wrench. Screw dimensions of M6 or smaller may be tightened without a torque wrench *if* this is done by trained and qualified personnel.

*Continues on next page*



Lubricant	Article number
Molykote 1000 (molybdenum disulphide grease)	3HAC042472-001
Molykote P1900 (molybdenum disulphide grease)	3HAC070875-001

### Tightening torque

Before tightening any screw, note the following:

- Determine whether a **standard** tightening torque or **special** torque is to be applied. The **standard torques** are specified in the following tables. Any **special torques** are specified in the repair, maintenance or installation procedure descriptions. **Any special torque specified overrides the standard torque!**
- Use the *correct tightening torque* for each type of screw joint.
- Only use *correctly calibrated* torque keys.
- *Always tighten the joint by hand*, and never use pneumatic tools.
- Use the *correct tightening technique*, that is *do not* jerk. Tighten the screw in a slow, flowing motion.
- Maximum allowed total deviation from the specified value is **10%!**

#### Tightening torque for oil-lubricated screws with slotted or cross-recess head screws

The following table specifies the recommended standard tightening torque for *oil-lubricated screws with slotted or cross-recess head screws*.



#### Note

A special torque specified in the repair, maintenance or installation procedure overrides the standard torque.

#### Tightening torque for oil-lubricated screws with allen head screws

The following table specifies the recommended standard tightening torque for *oil-lubricated screws with allen head screws*.



#### Note

A special torque specified in the repair, maintenance or installation procedure overrides the standard torque.

Dimension	Tightening torque (Nm)	Tightening torque (Nm)	Tightening torque (Nm)
	Class 8.8, oil-lubricated	Class 10.9, oil-lubricated	Class 12.9, oil-lubricated
M5	6	-	-
M6	10	-	-
M8	24	34	40
M10	47	67	80
M12	82	115	140
M16	200	290	340
M20	400	560	670

Continues on next page

## 7 Reference information

### 7.5 Screw joints

Continued

Dimension	Tightening torque (Nm) Class 8.8, oil-lubricated	Tightening torque (Nm) Class 10.9, oil-lubricated	Tightening torque (Nm) Class 12.9, oil-lubricated
M24	680	960	1150

Tightening torque for lubricated screws (Molykote, Gleitmo or equivalent) with allen head screws  
The following table specifies the recommended standard tightening torque for *screws lubricated with Molykote 1000, Gleitmo 603 or equivalent with allen head screws.*



#### Note

A special torque specified in the repair, maintenance or installation procedure overrides the standard torque.

Dimension	Tightening torque (Nm) Class 10.9, lubricated <sup>i</sup>	Tightening torque (Nm) Class 12.9, lubricated <sup>i</sup>
M5		8
M6		14
M8	28	35
M10	55	70
M12	96	120
M16	235	300
M20	460	550
M24	790	950

<sup>i</sup> Lubricated with Molykote 1000, Gleitmo 603 or equivalent

## 7.6 Weight specifications

### Definition

In installation, repair, and maintenance procedures, weights of the components handled are sometimes specified. All components exceeding 22 kg (50 lbs) are highlighted in this way.

To avoid injury, ABB recommends the use of a lifting accessory when handling components with a weight exceeding 22 kg. A wide range of lifting accessories and devices are available for each manipulator model.

### Example

Following is an example of a weight specification in a procedure:

	Action	Note
	 <b>CAUTION</b> The arm weighs 25 kg. All lifting accessories used must be sized accordingly.	

## 7 Reference information

---

### 7.7 Standard toolkit

### 7.7 Standard toolkit

---

#### General

All service (repairs, maintenance, and installation) procedures contains lists of tools required to perform the specified activity.

All special tools required are listed directly in the procedures while all the tools that are considered standard are gathered in the standard toolkit and defined in the following table.

This way, the tools required are the sum of the standard toolkit and any tools listed in the instruction.

---

#### Contents, standard toolkit

Qty	Tool	Rem.
1	Socket head cap 2-17 mm	
1	Torque wrench 0.3-45 Nm	
1	Torque wrench 45 Nm	For securing robot to foundation.
1	Ratchet head for torque wrench 1/2	
1	Hex socket head cap no. 2.5 socket 1/2" bit L=110 mm	
1	Small screwdriver	
1	T-handle with ball head	
1	Small cutting plier	
1	Plastic mallet	

## 7.8 Special tools

---

### General

All service instructions contain lists of tools required to perform the specified activity. The required tools are a sum of standard tools, defined in the section [Standard toolkit on page 392](#), and of special tools, listed directly in the instructions and also gathered in this section.

---

### Special tools



#### Note

If the replacing procedure is not listed in the table below, only standard tools are needed for the procedure.

*Continues on next page*

## 7 Reference information

### 7.8 Special tools

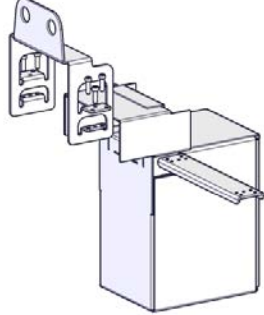
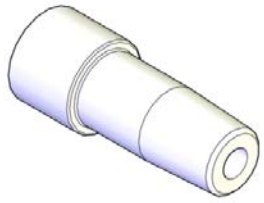
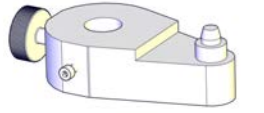
Tools and equipment with spare part number: (These tools can be ordered from ABB)			Cable harness spare parts	Base spare parts	Lower arm spare parts	Upper arm spare parts	Ball screw spline unit	Axis-1 motor	Axis-2 motor	Axis-3 motor	Axis-4 motor	Axis-3 timing belt	Axis-4 timing belts
<b>Lifting accessories</b>													
-	Lifting accessory, robot Includes lifting accessories and screws.	 xx1500002471											
-	Lifting chain, capacity > 50 kg. Hook												
<b>Calibration toolkit</b>													
3HAC057036-001	Moving calibration pin	 xx1500002518	1	1	1	1		1	1				
3HAC057137-001	Moving calibration block, axis3 and axis 4 Includes calibration pin, knob and adjusting screw.	 xx1500002682					1			1	1	1	1
<b>Other tools</b>													
-	24 VDC power supply						1						
-	Sonic tensiometer				1	1			1	1	1	1	
-	Dynamometer				1	1			1	1	1	1	

Continues on next page

## 7.9 Lifting accessories and lifting instructions

---

### General

Many repair and maintenance activities require different pieces of lifting accessories, which are specified in each procedure.

The use of each piece of lifting accessories is *not* detailed in the activity procedure, but in the instruction delivered with each piece of lifting accessories.

The instructions delivered with the lifting accessories should be stored for later reference.

**This page is intentionally left blank**



## 8 Spare parts

### 8.1 Spare part lists and illustrations

#### Location

Spare parts and exploded views are not included in the manual but delivered as a separate document for registered users on myABB Business Portal, [www.abb.com/myABB](http://www.abb.com/myABB).



#### Tip

All documents can be found via myABB Business Portal, [www.abb.com/myABB](http://www.abb.com/myABB).

**This page is intentionally left blank**

## 9 Circuit diagrams

### 9.1 Circuit diagrams

#### Overview

The circuit diagrams are not included in this manual, but are available for registered users on myABB Business Portal, [www.abb.com/myABB](http://www.abb.com/myABB).

See the article numbers in the tables below.

#### Controllers

Product	Article numbers for circuit diagrams
<i>Circuit diagram - IRC5 Compact</i>	<i>3HAC049406-003</i>

#### Manipulators

Product	Article numbers for circuit diagrams
<i>Circuit diagram - IRB 120</i>	<i>3HAC031408-003</i>
<i>Circuit diagram - IRB 140 type C</i>	<i>3HAC6816-3</i>
<i>Circuit diagram - IRB 260</i>	<i>3HAC025611-001</i>
<i>Circuit diagram - IRB 360</i>	<i>3HAC028647-009</i>
<i>Circuit diagram - IRB 390</i>	<i>3HAC060545-009</i>
<i>Circuit diagram - IRB 460</i>	<i>3HAC036446-005</i>
<i>Circuit diagram - IRB 660</i>	<i>3HAC025691-001</i>
<i>Circuit diagram - IRB 760</i>	<i>3HAC025691-001</i>
<i>Circuit diagram - IRB 1200</i>	<i>3HAC046307-003</i>
<i>Circuit diagram - IRB 1410</i>	<i>3HAC2800-3</i>
<i>Circuit diagram - IRB 1600/1660</i>	<i>3HAC021351-003</i>
<i>Circuit diagram - IRB 1520</i>	<i>3HAC039498-007</i>
<i>Circuit diagram - IRB 2400</i>	<i>3HAC6670-3</i>
<i>Circuit diagram - IRB 2600</i>	<i>3HAC029570-007</i>
<i>Circuit diagram - IRB 4400/4450S</i>	<i>3HAC9821-1</i>
<i>Circuit diagram - IRB 4600</i>	<i>3HAC029038-003</i>
<i>Circuit diagram - IRB 6620</i>	<i>3HAC025090-001</i>
<i>Circuit diagram - IRB 6620 / IRB 6620LX</i>	<i>3HAC025090-001</i>
<i>Circuit diagram - IRB 6640</i>	<i>3HAC025744-001</i>
<i>Circuit diagram - IRB 6650S</i>	<i>3HAC13347-1</i> <i>3HAC025744-001</i>
<i>Circuit diagram - IRB 6660</i>	<i>3HAC025744-001</i> <i>3HAC029940-001</i>
<i>Circuit diagram - IRB 6700 / IRB 6790</i>	<i>3HAC043446-005</i>

*Continues on next page*

## 9 Circuit diagrams

---

### 9.1 Circuit diagrams

*Continued*

<b>Product</b>	<b>Article numbers for circuit diagrams</b>
<i>Circuit diagram - IRB 7600</i>	<i>3HAC13347-1 3HAC025744-001</i>
<i>Circuit diagram - IRB 14000</i>	<i>3HAC050778-003</i>
<i>Circuit diagram - IRB 910SC</i>	<i>3HAC056159-002</i>

# Index

## A

Absolute Accuracy, calibration, 351  
 allergenic material, 28  
 aluminum  
   disposal, 380  
 ambient humidity  
   operation, 43  
   storage, 43  
 ambient temperature  
   operation, 43  
   storage, 43  
 assembly instructions, 39  
 assessment of hazards and risks, 28  
 axis-4 drive unit  
   replacing, 336  
 axis-3 drive unit  
   replacing, 322  
 axis-3 timing belt  
   replacing, 249  
 axis-2 drive unit  
   replacing, 311  
 axis-2 mechanical stop  
   replacing, 274  
 axis-1 drive unit  
   replacing, 302  
 axis-1 mechanical stop  
   replacing, 299

## B

ball screw spline unit  
   lubrication, 113  
   replacing, 232  
 base  
   replacing, 288  
 batteries  
   disposal, 380  
 battery pack  
   replacing, 102  
 brake release harness  
   replacing, 194  
 brakes  
   testing function, 36

## C

cabinet lock, 29  
 cabling, robot, 72  
 cabling between robot and controller, 72  
 calibrating  
   roughly, 355  
 calibration  
   Absolute Accuracy type, 350  
   rough, 355  
   standard type, 350  
   verification, 376  
   when to calibrate, 352  
 calibration, Absolute Accuracy, 351  
 calibration manuals, 351  
 calibration marks, 353  
 calibration position  
   jogging to, 377  
   scales, 353  
 calibration scales, 353  
 CalibWare, 350  
 carbon dioxide extinguisher, 29

cleaning, 116  
 climbing on robot, 32  
 Cold environments, 76  
 connecting the robot and controller, cabling, 72

## D

dimensions  
   robot, 67  
 direction of axes, 354

## E

EIB mounting plate  
   replacing, 167  
 EIB unit  
   replacing, 149  
 environmental information, 380  
 equipment, robot, 67  
 ESD  
   damage elimination, 53  
   sensitive equipment, 53  
 extra equipment, 67

## F

fire extinguishing, 29  
 fitting, equipment, 67  
 FlexPendant  
   jogging to calibration position, 377  
   MoveAbsJ instruction, 377  
   updating revolution counters, 356  
 floor cables  
   replacing, 186  
 foundation  
   requirements, 43

## G

grease, 32  
 disposal, 380

## H

hanging  
   installed hanging, 28  
 hazard levels, 19  
 hazardous material, 380  
 height  
   installed at a height, 28  
 hot surfaces, 32  
 HRA, 28  
 humidity  
   operation, 43  
   storage, 43

## I

installation  
   equipment, 67  
 instructions for assembly, 39  
 integrator responsibility, 28  
 intervals for maintenance, 82

## L

labels  
   robot, 21  
 lifting accessory, 391  
 limitation of liability, 17  
 Lithium  
   disposal, 380  
 loads on foundation, 42  
 lock and tag, 29

lower arm  
  replacing, 279  
lubricants, 32  
lubrication  
  ball screw spline unit, 113

## M

main cable package  
  replacing, 125  
maintenance intervals, 82  
maintenance schedule, 82  
mounting, equipment, 67  
MoveAbsJ instruction, 377

## N

national regulations, 28  
negative directions, axes, 354  
neodymium  
  disposal, 380

## O

oil, 32  
  disposal, 380  
operating conditions, 43  
original spare parts, 17

## P

PCB board  
  replacing, 159  
pedestal  
  installed on pedestal, 28  
personnel  
  requirements, 18  
plastic  
  disposal, 380  
positive directions, axes, 354  
PPE, 18  
product standards, 384  
protection classes, 44  
protection type, 44  
protective equipment, 18  
protective wear, 18

## R

recycling, 380  
regional regulations, 28  
release brakes, 35  
replacements, report, 119  
replacing  
  axis-4 drive unit, 336  
  axis-3 drive unit, 322  
  axis-3 timing belt, 249  
  axis-2 drive unit, 311  
  axis-2 mechanical stop, 274  
  axis-1 drive unit, 302  
  axis-1 mechanical stop, 299  
  ball screw spline unit, 232  
  base, 288  
  battery pack, 102  
  brake release harness, 194  
  EIB mounting plate, 167  
  EIB unit, 149  
  floor cables, 186  
  lower arm, 279  
  main cable package, 125  
  PCB board, 159  
  timing belts, 259

  upper arm, 199  
  report replacements, 119  
  requirements on foundation, 43  
  responsibility and validity, 17  
  revolution counters  
    storing on FlexPendant, 356  
    updating, 355  
  risk of burns, 32  
  risk of tipping, 51  
  robot  
    dimensions, 67  
    equipment, fitting, 67  
    labels, 21  
    protection class, 44  
    protection types, 44  
    symbols, 21  
  rubber  
    disposal, 380

## S

safety  
  brake testing, 36  
  ESD, 53  
  fire extinguishing, 29  
  release robot axes, 35  
  signals, 19  
  signals in manual, 19  
  symbols, 19  
  symbols on robot, 21  
  test run, 77  
safety devices, 29  
safety hazard  
  hydraulic system, 30  
  pneumatic system, 30  
safety signals  
  in manual, 19  
safety standards, 384  
scales on robot, 353  
schedule of maintenance, 82  
screw joints, 388  
securing, robot, 64  
shipping, 379  
signals  
  safety, 19  
speed  
  adjusting, 76  
stability, 51  
standards, 384  
  ANSI, 384  
  CAN, 384  
  EN IEC, 384  
  EN ISO, 384  
start of robot in cold environments, 76  
steel  
  disposal, 380  
  storage conditions, 43  
  symbols  
    safety, 19  
  synchronization position, 355  
  sync marks, 353  
  system integrator requirements, 28

## T

temperatures  
  operation, 43  
  storage, 43  
testing

- brakes, 36
- timing belts
  - replacing, 259
- torques on foundation, 42
- transportation, 379
- troubleshooting
  - safety, 37

## U

- upcycling, 380
- updating revolution counters, 355
- upper arm
  - replacing, 199
- users

- requirements, 18

## V

- validity and responsibility, 17
- velocity
  - adjusting, 76
- verifying calibration, 376

## W

- weight, 41
  - robot, 59, 65

## Z

- zero position
  - checking, 377









**ABB AB**

**Robotics & Discrete Automation**

S-721 68 VÄSTERÅS, Sweden

Telephone +46 10-732 50 00

**ABB AS**

**Robotics & Discrete Automation**

Nordlysvegen 7, N-4340 BRYNE, Norway

Box 265, N-4349 BRYNE, Norway

Telephone: +47 22 87 2000

**ABB Engineering (Shanghai) Ltd.**

Robotics & Discrete Automation

No. 4528 Kangxin Highway

PuDong New District

SHANGHAI 201319, China

Telephone: +86 21 6105 6666

**ABB Inc.**

**Robotics & Discrete Automation**

1250 Brown Road

Auburn Hills, MI 48326

USA

Telephone: +1 248 391 9000

**[abb.com/robotics](http://abb.com/robotics)**